

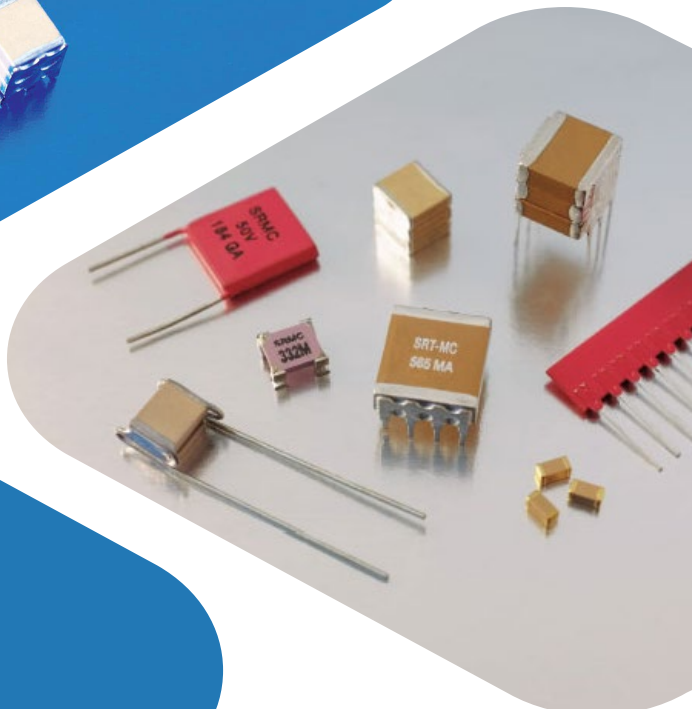

SRT

MICROCÉRAMIQUE

MLCC CAPACITORS

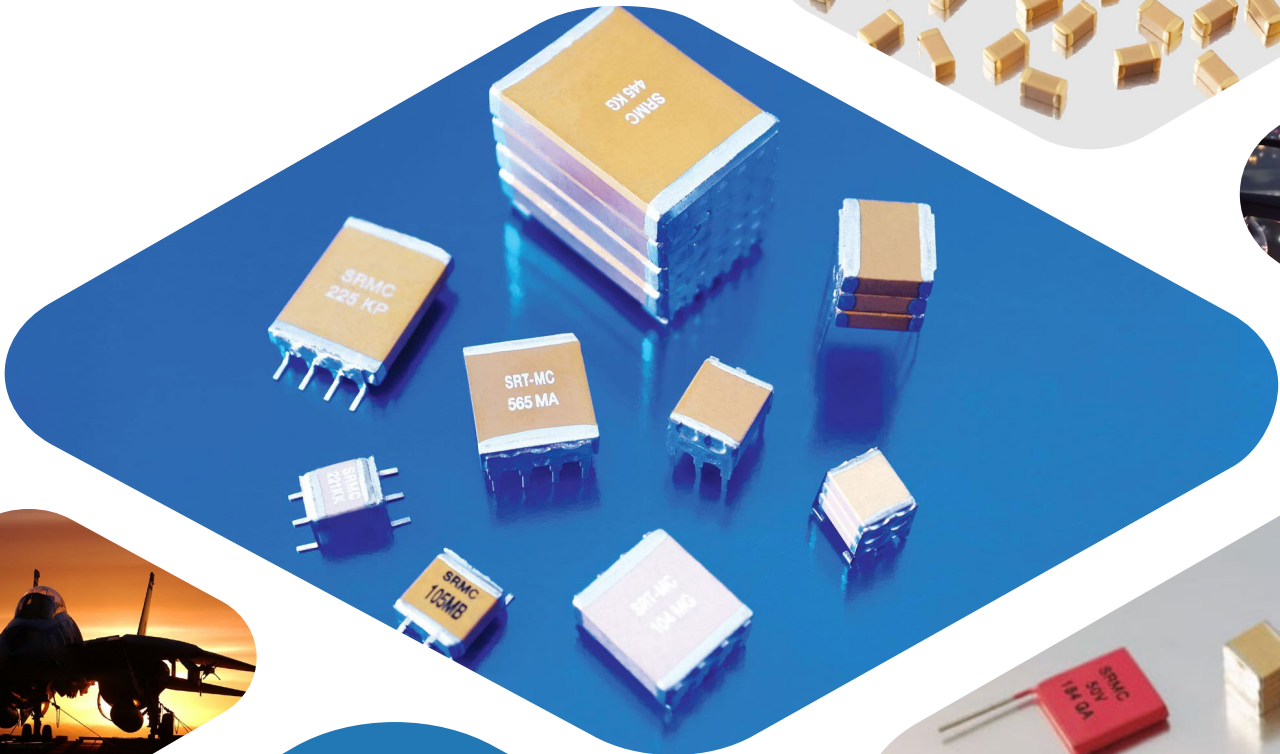

- › MLCC, FILTERS, STACK, RADIAL
- › STANDARD AND CUSTOM PRODUCTS
- › HIGH VOLTAGE, FREQUENCY, PRECISION
- › HIGH REACTIVITY, SHORT LEAD TIMES
- › SERVICE PROVIDER
- › COMPLETE PASSIVE & THERMAL SOLUTIONS
- › MANUFACTURED IN FRANCE

SRT MICROCÉRAMIQUE

We manufacture MultiLayer Ceramic Capacitors and filters in France. Established in 1982 in Vendôme by former Vishay-Vitramon employees, SRT-Microcéramique is one of the only two companies still producing MLCCs in Europe. We are specialized in high value components, high voltage, high frequency, high precision, low ESL, non-magnetic components and precision filters.

*Manufactured in Europe,
short lead time guaranteed
(4 to 8 weeks)
No obsolescence*

Applications of our products are commercial aerospace, defense, medical application both implementable and imagery, space level, military aircraft and ground based systems, high temperature (geophysical and geothermal), pulse discharge and high repetition rate and a variety of commercial and industrial applications.



OUR PRODUCTS

Range from Multi-layer Surface Mount Chip, to Stack, Radial leaded and vertical layers capacitors and filters in a variety of dielectrics and the full range of termination to suit your applications. We can produce large or small quantities.

*Cross reference to most competitors designs :
Exxelia, Syfer, Kemet, Presidio...*

Due to our very flexible production we can guarantee the absence of obsolescence. Our highly qualified engineer team works in close cooperation with our customers to develop custom designs and variations for their specific need.



SMD

- 0201 -> 8060
- COG, X7R, High Q, HT
- Voltage : 16V -> 15KV
- Polymer option
- Sn, Au, AgPd term

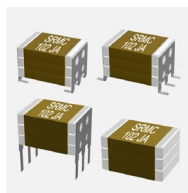

STACKS

- High power
- Low volume
- High reliability

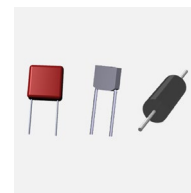

RADIALS

- Encapsulated
- Dipped
- Severe environment
- Historical design



NON MAGNETIC

- Cu-Sn termination
- All SMD available
- Medical application
- High Tesla

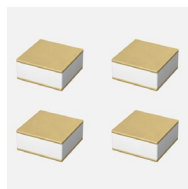

MICROELECTRONIC

- Vertical layer 0303
- Au termination for bonding
- 0202 single layer (2021)

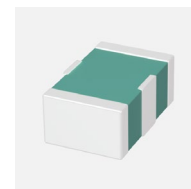

FILTERS

- EMI M2F MCF MPF series
- High precision
- Large currents



SPECIAL DESIGN

- Barcap capacitors
- Capacitors arrays
- Large cases

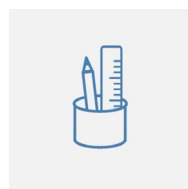

CUSTOMS

- Very high tension 32K
- Any value
- Any size
- Any Voltage



SnPb/SAC

- Dipped or electrolytic
- Medical application
- Space application

This document is subject to change without notice.

SERVICES

Thanks to our cutting edge industrial equipment to produce MLCCs, we also offer a large range of services to our partners : full silver-nickel/tin termination process of various electronic components, termination change to lead/silver for medical and space applications, precision sorting and taping, testing and burn-in for high Reliability needs.

TERMINATION	PRECISION SORTING	BURN IN/TESTING	TERMINATION CHANGE	TAPING	SOURCING
Various SMD components Medical, Space application	Up to 0,03%	High Reliability test program	Ag/Pd Sn/Pb Cu/Sn SAC Medical, Space applications	We can put on reel any kind and any volume of components	Passive and active components from multiple source at best price

THEY TRUST US

Over the years, we developed close relationships with large international groups and high technology companies, for which we provide unique services and custom products.

Our relationship is based on a culture of trust, service and open communication.

MARKETS APPLICATIONS

AEROSPACE INDUSTRIAL MEDICAL ENERGY RAIL SPACE TELECOM MILITARY

QUALITY AND CERTIFICATIONS

In order to ensure the highest reliability to our customers our quality process includes a full traceability, 100% visual and electrical test and burn-in. For special requirements we can offer stronger qualification programs including, vrt, humidity test, life test, thermal shock, vibration test, shear test, pull test...



We follow internally AECQ200 and MIL-STD-202 testing SRT-Microcéramique is ISO-9001 since 2002. We are REACH and conflict of minerals compliant. Most of our products are ROHS certified.

PASSIVE AND THERMAL SOLUTIONS

Our distribution branch Milton Ross Composants, in addition to our own ceramic production can offer the full range (except tantalum) of capacitors (film, electrolytic) and resistors (thick film, thin film, wirebound) through our partnership with specialized manufacturers (mainly European) offering the same high value product, high voltage, high precision, large values, custom products with always the shortest lead time.



INNOVATION : HYDROGEN FUEL

In addition to our constant R&D to improve and innovate in our MLCC discipline we are leveraging our unique ceramic process knowledge to develop in collaboration with the CEA an innovative ceramic fuel cell production line offering the highest performance of the market.



GENERAL INFORMATION

Company.....	2
Services.....	3
Table of Content.....	4
Dielectric Types.....	6
Terminations details.....	7
Storage and Soldering.....	8
Footprint.....	11
How to order, Reliability, Sorting options.....	12
Packaging dimension and quantity.....	13
Tests and Qualifications.....	14
Tests and Qualifications Space applications.....	15
Construction.....	16
Regulation and compliance.....	17

SMD LOW VOLTAGE

SMD Low Voltage Class I.....	18
SMD Low Voltage N2T.....	22
SMD Low Voltage Class II.....	26
High Capacitance capacitors.....	30
Low Inductance Capacitors Class II.....	33

SMD HIGH VOLTAGE

SMD High Voltage Class I.....	36
SMD High Voltage N2T.....	40
SMD High Voltage Class II.....	44

NON MAGNETIC

Non Magnetic SMD.....	48
-----------------------	----

SPACE MEDICAL APPLICATION

Space Medical application.....	49
--------------------------------	----

HIGH TEMPERATURE

SMD High Temperature Class I.....	50
SMD High Temperature Class II.....	52

SAFETY CAP

Safety Certified MLCC.....	54
----------------------------	----

HIGH Q

MLCC High Q.....	56
MLCC High Q RF Power.....	59
MLCC High Q Design Kits.....	64

MICROELECTRONIC

RF DECOUPLING X7R Vertical Electrodes Capacitor.....	65
SMD Gold Termination.....	67

FILTERS

EMI MCF Filter.....	69
EMI M2F Filter.....	71



EMI MPF Filter..... 73

STACKED

STACKED CAPACITOR High Power..... 75
 STACKED CAPACITOR High Voltage..... 78
 STACKED CAPACITOR Vertical..... 81
 STACKED CAPACITOR High Compact..... 84

THROUGH HOLE

RADIAL CAPACITOR Dipped High Power..... 87
 RADIAL CAPACITOR Dipped High Voltage..... 89
 RADIAL CAPACITOR Encapsulated..... 91
 AXIAL CAPACITOR Encapsulated..... 93

CUSTOM PRODUCTS

CUSTOM PRODUCTS..... 95

CROSS REFERENCES

SMD CAPACITORS..... 96
 RADIAL CAPACITOR Dipped..... 98
 RADIAL CAPACITOR Encapsulated..... 99
 AXIAL CAPACITOR Encapsulated..... 100
 STACKED CAPACITOR Horizontal..... 101
 STACKED CAPACITOR Vertical..... 102
 FILM CAPACITORS..... 103

Different types of dielectrics display very different behaviours when it comes to withstanding power and heat, and don't demonstrate the same capacitance potential. SRT-Microcéramique proposes a wide range of ceramics. You'll find in the page below more information about what type of ceramic is better suited to your needs.

Class I Dielectrics

Class I Dielectrics are the most stable type and are used when the application demands highly stable performance and cannot allow electrical noise or dielectric loss. Variations of voltage and temperature have minimum consequences on this class of dielectrics, consequently, they are most used for DC blocking, decoupling applications as well as filtering with low capacitance.

Q (Code Q)

- Most stable type
- Low capacitance
- Good for avoiding electrical noise

NPO (Code A)

- Most stable type
- Lower capacitance
- Good for avoiding electrical noise

Class 1.5 Dielectrics

Close to Class II capacitance and as stable than Class I

N2T (Code P)

- Ultra stable
- No piezo electric effect
- High current pulse discharge

Class II Dielectrics

Class II Dielectrics display stable performance and possess a better volumetric efficiency than class I. Thus, they are used in bypassing, filtering, coupling and decoupling applications.

X7R (Code Y)

- Good volumetric efficiency
- High capacitance
- stable

BX/BY (Code X/2C1)

- Improved ESR
- Better voltage coefficient
- MIL specifications

X5R/X7S/X6S/Y5V (Code R/T/S/V)

- Highest capacitance per volume
- Less stable
- Low voltage

Dielectric	Class I		Class 1.5	Class II						
	High Q	NPO/COG	N2T	X7R	BX	2C1	X5R	X7S	X6S	Y5V
SRT Code	Q	A	P	Y	X	2C1	R	T	S	V
Type	Ultra Stable			Stable						
Temperature Range	-55°C +125°C (250°C)		-55°C +125°C			-55°C +85°C		-55°C +125°C	-55°C +105°C	-25°C +85°C
T° Coefficient no DC applied	± 30ppm		2200ppm ± 350	± 15%		± 20%	± 15%	± 22%		+30% -80%
T° Coefficient rated DC applied	-		-	-	+15 -25%	+20 -30%	-	-	-	-
Dielectric constant	10-100		450	2000-3000			3000-20000			
Dissipation Factor	0.01% 0.05%	0.05% 0.1%		1% 3.5%			2.5% 15%		5% 20%	
IR 25°C/Un	100 GΩ or 1000 Ω-F whichever is less						10 GΩ or 100 Ω-F whichever is less			
Dielectric strenght ≤200V	2.5 Ur 5 seconds 50mA max									
Dielectric strenght <500V	Ur + 250V 5 seconds 50mA max									
Dielectric strenght <1000V	1.5 Ur 5 seconds 50mA max									
Dielectric strenght ≥1000V	1.2 Ur 5 seconds 50mA max									
Piezo effect	No piezo			piezo effect						
Ageing	None			2% per decade	1% per decade		4% per decade	5% per decade		7% per decade
Tolerance	± 0.25pF ± 0.5pF ± 1% ± 2% ± 5% ± 10%			± 5% ± 10% ± 20%			± 10% ± 20%		-20% +80%	
Termination	X,C,H		X,F,P,C,W,H,I			X,P		X		

This document is subject to change without notice.



All our capacitors are available with a wide range of termination to fit your specific needs :

Tin (Code X)

- Standard termination
- ROHS
- Dipped Silver, Nickel barrier, Sn plated

Polymer (Code P)

- Flexible termination
- Improve bending tolerance
- ROHS
- Available on all components
- Designed for gluing

Silver-Palladium (Code F)

- Excellent contact properties
- Resist to leaching during hand soldering
- Dipped Silver-Palladium
- ROHS

Gold Flash (Code W)

- Glueing
- ROHS
- Max 0.2µm Gold Flash

Gold Thick (Code W)

- Microelectronic applications
- Wire Bonding/glueing
- ROHS
- Min 2.5µm Gold

Non Magnetic (Code C/CP)

- High Tesla Applications
- IRM, particule accelerators
- Dipped Silver, Copper barrier, Sn plated
- ROHS

Solderable Silver (Code Q)

- Medical or space application
- Whiskers free
- High temperature
- ROHS

Dipped SAC 305 (Code S/SP)

- Sn96.5 Ag3 Cu0.5
- Medical, space and oil application
- Whiskers free
- High reliability
- ROHS

Dipped Tin-Lead (Code H/HP)

- Sn62 Pb36 Ag2
- Medical or Oil application
- Whiskers free
- High reliability

Electrolytical Tin-Lead (Code I/IP)

- Minimum Pb 10%
- Medical or space application
- Whiskers free
- High reliability

TERMINATION	CODE	ROHS	NON MAGNETIC	IMPROVED BOARD FLEX	SOLDERING	GLUING	WIRE BONDING
Sn	X	0			0		
Polymer	P	0		0	0		
AgPd	F	0			0	0	
Gold Flash	W	0			0	0	
Gold Thick	G	0			0	0	0
Non Magnetic	C	0	0		0		
Solderable Silver	Q	0			0		
Dipped SnPb	H				0		
Dipped SAC	S	0			0		
Electrolytical SnPb	I				0		
Lead	-	0		0	0		
Non Magn Lead	C	0	0	0	0		
Lead Frame	-	0		0	0		
Non Magn Lead Frame	C	0	0	0	0		

0 = COMPLIANT

STORAGE

To prevent the damage of solderability of terminations, the following storage conditions are recommended :

Indoors under 5 ~ 40°C and 20% ~ 70% RH.

No harmful gases containing sulfuric acid, ammonia, hydrogen sulfide or chlorine.

Packaging should not be opened until the capacitors are required for use. If opened, the pack should be re-sealed as soon as possible. Taped products should be stored out of direct sunlight, which might promote deterioration in tape or adhesion performance. The product is recommended to be used within 24 months after shipment. Extended shelf life over this period require a solderability check before use.

HANDLING

Chip capacitors are dense, hard, brittle, and abrasive materials. They are liable to suffer mechanical damage, in the form of cracks or chips. Chip Capacitors should be handled with care to avoid contamination or damage. To use vacuum or plastic tweezers to pick up or plastic tweezers is recommended for manual placement. Tape and reeled packages are suitable for automatic pick and placement machine.

PREHEAT

In order to minimize the risk of thermal shock during soldering, a carefully controlled preheat is required.

The rate of preheat should not exceed 3°C per second.

SOLDERING FLUX

Use mildly activated rosin RA and RMA fluxes, but do not use activated flux. The amount of solder in each solder joint should be controlled to prevent the damage of chip capacitors caused by the stress between solder, chips, and substrate.

SOLDERING TYPE

Lead containing solders, such as Sn60, Sn62 or Sn63 and lead free solders, such as SnAgCu, can all be used with our MLCCs.

In case of non-magnetic termination code C, use lead containing or lead (Pb)-free SAC305 solders.

SOLDERING HEIGHT

The solder climbing minimum height is suggesting to 25% of chip thickness or 500um whichever is less.

(Reference from IPC-610E)

COOLING

After soldering, cool the chips and the substrate gradually to room temperature. Natural cooling in air is recommended to minimize stress in the solder joint.

CLEANING

All flux residues must be removed by using suitable electronic-grade vapor-cleaning solvents to eliminate contamination that could cause electrolytic surface corrosion. Good results can be obtained by using ultrasonic cleaning of the solvent. The choice of the proper system is depends upon many factors such as component mix, flux, and solder paste and assembly method. The ability of the cleaning system to remove flux residues and contamination from under the chips is very important.

SOLDERING CONDITIONS

SIZE	THICKNESS	WAVE	REFLOW
0402	All	0	0
0505	All	0	0
0603	All	0	0
0805	< 1.25mm	0	0
0805	≥ 1.25mm	0	0
1111	< 1.25mm	0	0
1111	≥ 1.25mm	0	0
1206	< 1.25mm	0	0
1206	≥ 1.25mm	0	0
1210	< 1.25mm	0	0
1210	≥ 1.25mm	0	0
larger than 1210	All	0	0
High compact	All	0	0

WAVE SOLDERING PROFILE

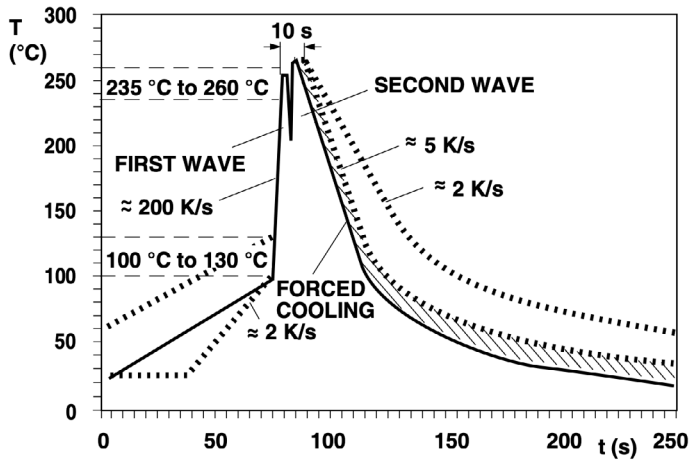

LEADFREE REFLOW SOLDERING PROFILE

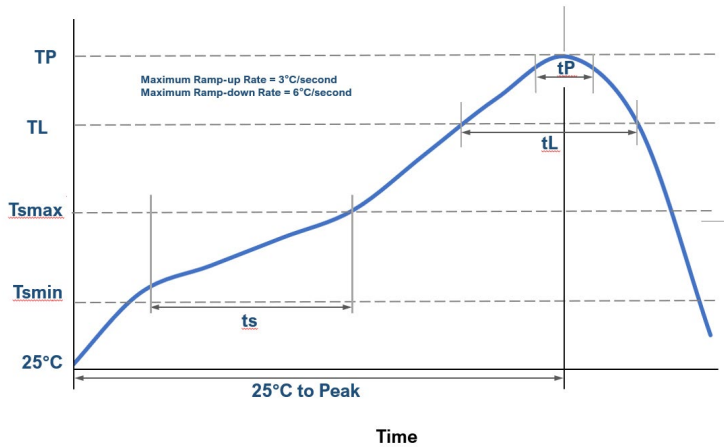

PROFILE FEATURE	LEAD FREE (SAC 305)
Tsmin	150°C
Tsmax	190°C
Time from Tsmin to Tsmax	60 - 120 seconds
Ramp-up Rate	3°C/second max
Liquidous Temperature	217°C
Time above Liquidous	60 - 120 seconds
Peak Temperature	250°C
Time within 5°C of maximum	10 seconds max
Peak Temperature	250°C
Ramp-down Rate	6°C/second max
Time 25°C to Peak	8min max

SNPB REFLOW SOLDERING PROFILE

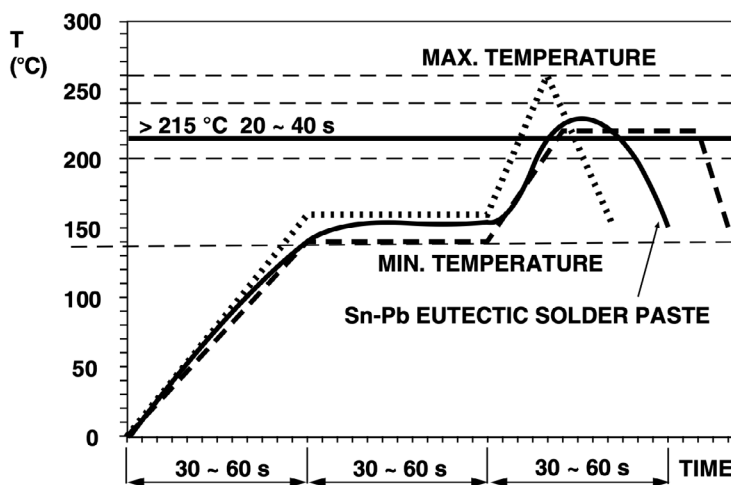

VAPOUR PHASE REFLOW PROFILE

This document is subject to change without notice.

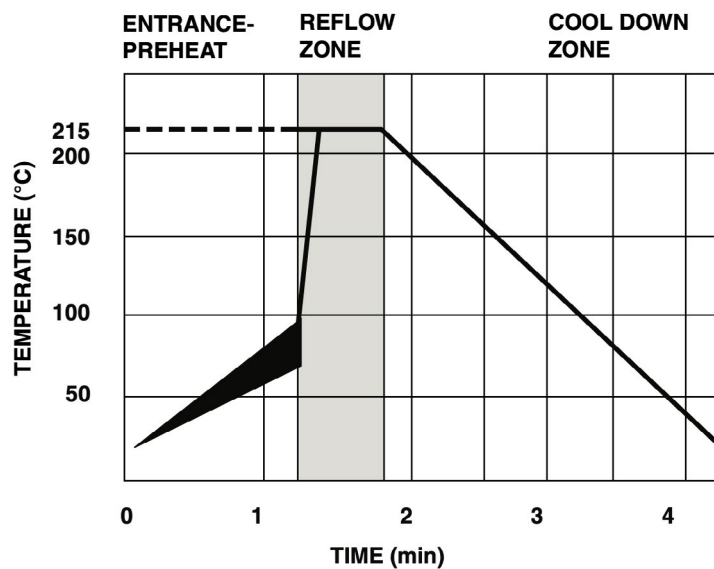

HAND SOLDERING

Hand soldering is not recommended as the thermal shock may cause a crack, however if used the following recommendations should be taken :

- Soldering iron tip diameter ≤ 3.0 mm and wattage max. 20W.
- The Capacitors shall be pre-heated to 150°C and that the temperature gradient between the devices and the tip of the soldering iron.
- Tip temperature ≤ 280 °C and should't be applied for more than 5 seconds.
- The required amount of solder shall be melted on the soldering tip.
- The tip of iron should not contact the ceramic body directly.
- The Capacitors shall be cooled gradually at room temperature after soldering.
- Forced air cooling is not allowed.

TYPICAL SMD FOOTPRINT WAVE SOLDERING

SIZE	FOOTPRINT DIMENSIONS IN MM					
	A	B	C	D	E	F
0603	2.40	0.80	0.70	1.00	3.10	1.40
0805	3.20	1.30	0.90	1.40	4.10	1.85
1206	4.80	1.70	1.25	2.30	5.90	2.25
1210	4.80	2.60	1.25	2.30	5.90	3.15

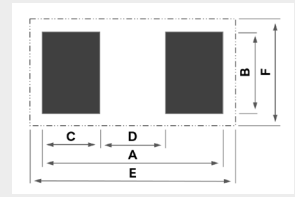

TYPICAL SMD FOOTPRINT REFLOW SOLDERING

SIZE	FOOTPRINT DIMENSIONS IN mm					
	A	B	C	D	E	F
0201	0.65	0.30	0.21	0.23	0.90	0.60
0204	1.00	1.00	0.30	0.40	1.25	1.45
0402	1.50	0.50	0.40	0.70	1.75	0.95
0306	1.30	1.60	0.40	0.50	1.55	2.05
0404	1.50	1.00	0.40	0.70	1.75	1.45
0504	1.90	1.00	0.40	1.10	2.15	1.45
0505	1.90	1.30	0.50	0.80	2.15	1.75
0508	1.90	2.00	0.50	0.90	2.15	2.55
0603	2.30	0.80	0.60	1.10	2.55	1.35
0612	2.30	3.20	0.60	1.10	2.55	3.75
0805	2.90	1.25	0.90	1.10	3.15	1.80
1206	4.10	1.60	0.90	2.30	4.35	2.25
1210	4.10	2.50	1.00	2.10	4.35	3.15
1808	5.50	2.10	1.20	3.10	5.75	2.75
1812	5.50	3.30	1.20	3.10	5.75	3.95
1825	5.50	6.55	1.20	3.10	5.75	7.20
2211	6.80	3.00	1.40	4.00	7.05	3.65
2220	6.80	5.40	1.40	4.00	7.05	6.05
2225	6.80	6.70	1.65	3.50	7.05	7.50
2525	7.70	6.75	1.65	4.40	7.95	7.55
2825	8.40	6.70	1.65	5.10	8.65	7.50
3033	9.00	8.80	1.95	5.10	9.25	9.60
3640	10.55	10.70	2.35	5.85	10.80	11.50
4040	11.60	10.70	2.35	6.90	11.85	11.50
40100	11.60	26.20	2.35	6.90	11.85	27.00
5550	15.50	13.20	2.35	10.80	15.75	14.00
6080	16.70	20.80	2.35	12.00	16.95	21.60
6660	18.30	15.70	2.35	13.60	18.55	16.50
8060	21.90	15.70	2.35	17.20	22.15	16.50
80150	21.90	38.90	2.35	17.20	22.15	39.70
HIGH COMPACT 1210	4.15	2.60	1.15	1.85	5.05	3.30
HIGH COMPACT 1812	5.75	3.40	1.35	3.05	6.70	4.20
HIGH COMPACT 2220	6.80	5.50	1.70	3.40	7.70	6.30

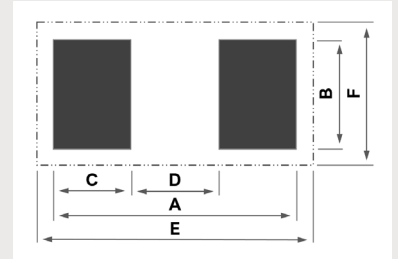

TYPICAL FILTER FOOTPRINT REFLOW SOLDERING

SIZE	FOOTPRINT DIMENSIONS IN mm						
	A	B	C	D	G	H	I
0603	2.30	0.80	0.45	1.40	0.60	0.40	1.50
0805	2.90	1.25	0.90	1.80	0.80	0.50	2.00
1206	4.10	1.60	0.90	2.40	1.00	0.70	3.00
1806	5.50	1.60	1.20	3.20	1.00	1.10	3.00
1812	5.50	3.30	1.20	3.90	1.50	1.20	4.80
2220	6.80	5.40	1.40	4.50	1.50	1.50	7.00

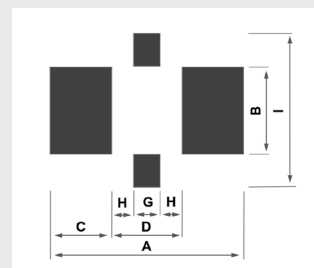

This document is subject to change without notice.



ORDERING INFORMATION

SRMC	0603	Y	102	J	A	-	L	040	-	-	-	B	-
SERIE	SIZE	DIELECTRIC	CAPACITANCE	TOLERANCE	VOLTAGE	TERMINAISON	FORM	HEIGHT	LEADS	COATING	CUR-RENT	PACKAGING	SPECIAL
-	0201	Q = High Q	Expressed in picofarads (pF)	A = ± 0.05pF/0.1%	Y = 4V	- = Sn lead/lead frame	-	020	-	-	-	B = Reel	-
FK	0204	A = NPO		B = ± 0.1pF	R = 6.3V	X = Nickel Tin	J	030	2 to 10	-	1	V = Bulk	BM = BME
FH	0402	P = N2T	The first two digits are significant,	C = ± 0.25pF	Q = 10V	F = Palladium-Silver	L	040	B	I = Conformal-Coating	2	T = Tray Package	Dxx = Reliability spec
SREV	0303	X = BX	the third digit gives the number of noughts	D = ± 0.5pF	J = 16V	P = Polymer Tin (Flex)	D	050		H = EpoxyCoating		W = Waffle Pack	Exx = Sorting spec
MCF	0306	Y=X7R		E = ± 0.5%	X = 25V	C = Copper Tin (Non magnetic)	M	060					H = High Reliability
M2F	0404	BY=2C1		F = ± 1%	Z = 35V	CP = Copper Polymer Tin (Non magnetic)	T = 2	070					Q = Anti-Arcing
MPF	0505	T = X7S	Example : 102 = 1 000pF	G = ± 2%	A = 50V	W = Nickel Gold Flash	leads	080					E = Anti Bending
SRMC	0508	S = X5R		J = ± 5%	U = 63V	G = Nickel Gold Thick	U = 4	090					Z = Anti-Arcing + Anti-Bending
SRTV	0603	R = X6S		K = ± 10%	B = 100V	HP = Dipped SnPb Polymer	leads	100					
SR	0612	V = Y5V	For special values R is used as decimal separator	M = ± 20%	C = 200V	H = Dipped SnPb		110					
SA	0805	U = X8R	Example 12R7 = 12.7pF	Z = -20% +80%	P = 250V	S = Dipped SAC		120					
H	1206		Example 1340R0 = 1340pF		D = 300V	SP = Polymer Dipped SAC		130					
	1210				E = 500V	I = Electrolytic SnPb		140					
	1808				F = 630V	IP = Polymer Electrolytical SnPb		160					
	1812				G = 1000V	Q = Solderable Silver		180					
	1825				O = 1500V	M = Microstrip							
	2211				H = 2000V	A = Axial Ribbon							
	2220				T = 2500V	R = Radial Ribbon							
	2225				I = 3000V	U = Axial Wire							
	2325				M = 3600V	V = Radial Wire							
	2525				K = 4000V	CM = Microstrip (Non magnetic)							
	2825				L = 5000V	CA = Axial Ribbon (Non magnetic)							
	3033				6 = 6000V	CR = Radia Ribbon (Non magnetic)							
	3640				S = 7200V	CU = Axial Wire (Non magnetic)							
	4040				8 = 8000V	CV = Radial Wire (Non magnetic)							
	40100				10 = 10000V								
	5550				12 = 12000V								
	6080				15 = 15000V								
	6660												
	7274												
	8060												
	80150												
	15080												
	40 to 94												

RELIABILITY

OPTIONAL CODE	TESTING DETAIL
D03	Burn-In 100% 125° 168H, no default allowed
D05	Burn-In 100% 125° 168H, less than 5% default allowed VRT CEI 68-2-14 10 cycles 0V -55°C/+125°C, less than 5% default allowed 20 pieces life test 125°C, 1.5U, 1 default allowed
D20	AECQ-200
D3009CFM	Screened and LAT according to ECSS-3009 for space application C Level
D3009CFM	Evaluation version for space development according to ECSS-2310 C Level
COTS1	Class 1 COTS+ according to ECSS-Q-ST-60-13C-Rev1
COTS2	Class 2 COTS+ according to ECSS-Q-ST-60-13C-Rev1
COTS3	Class 3 COTS+ according to ECSS-Q-ST-60-13C-Rev1

SORTING

OPTIONAL CODE	SORTING DETAIL
E01	2 cells sorting 0 to +2,5 & +2,5 to +5 (% or pF according to value)
E02	4 cells sorting -5 to -2,5 ; -2,5 to 0 ; 0 to +2,5 & +2,5 to 5 (% or pF according to value)
E21	2% cells

PACKAGE DIMENSION AND QUANTITY

SIZE	THICKNESS	PAPER TAPE		PLASTIC TAPE	
		7 REEL	13 REEL	7' REEL	13 REEL
0402	0.5 ± 0.05	10 K	50 K		
0504	0.6 ± 0.05			4K	15K
	0.9 ± 0.05			4K	15K
0603	0.7 ± 0.07	4K		4K	15K
	0.9 ± 0.07	4K	15K	4K	15K
	0.9 ± 0.07			4K	15K
	1.1 ± 0.07			4K	15K
0805	0.8 ± 0.07	4K	15K	4K	15K
	0.9 ± 0.07			4K	10K
	1.1 ± 0.07			3K	10K
	1.3 ± 0.07			3K	10K
1206	1.1 ± 0.1			3K	10K
	1.4 ± 0.1			3K	8K
	1.8 ± 0.1			2K	8K
1210	1.4 ± 0.1			3K	8K
	1.8 ± 0.1			1K	6K
1808	1.4 ± 0.1			3K	8K
1812	1.6 ± 0.1			2K	8K
	2.1 ± 0.1			1K	6K
	2.8 ± 0.1			1K	6K
2220	1.8 ± 0.1			1K	6K
	3.0 ± 0.1			0.5K	2K
2225	3.0 ± 0.1			0.5K	2K
3033	3.0 ± 0.1			0.5K	2K
3640	3.0 ± 0.1			0.5K	2K
5440	3.9 ± 0.1				0.5K - 1K
HIGH COMPACT 1210				1K	6K
HIGH COMPACT 1812				1K	6K
HIGH COMPACT 2220				0.5K	2K

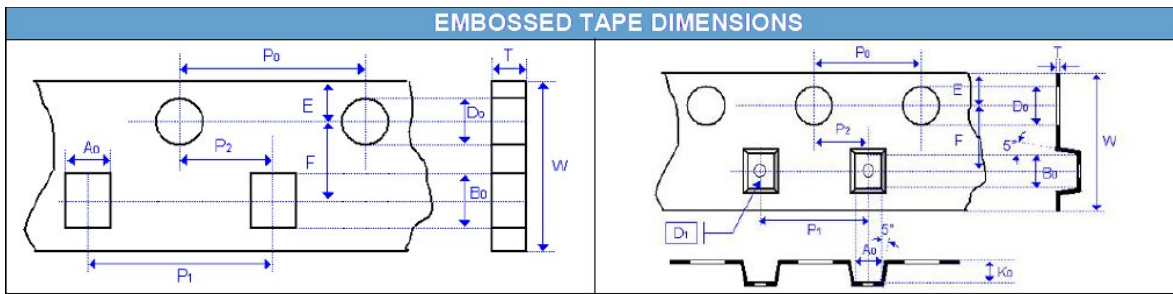

REEL SIZE	7	7	13
C	13.0 +0.5/-0.2	13.0 +0.5/-0.2	13.0 +0.7/-0.3
W1	8.4 +1.5/-0	12.4 +2.0/-0	8.4 +2.0/-0
A	178.0 ±0.10	178.0 ±0.10	330.0 ±1.0
N	60.0 ±1.0	80.0 ±1.0	100 ±1.0

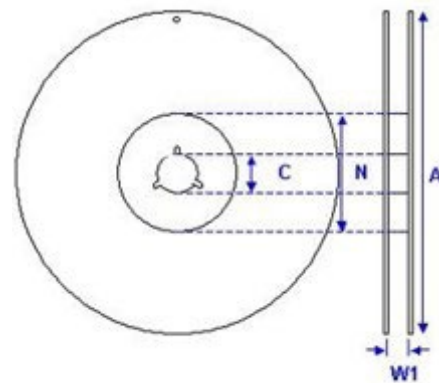

This document is subject to change without notice.

RELIABILITY PRINCIPLES OVERVIEW GENERAL PRODUCTION

In order to guarantee highly reliable products to their customers, SRT-Microcéramique follows a strict quality policy which is explained below :

- According to AECQ philosophy, each component belongs to a family, which most restrictive members (four corners) have been fully qualified.
- PME components are produced in our Vendôme facility, with very stable process and equipments, in order to ensure Reliability and reproductibility.
- Reliability is based on batch tests, new product or equipment-specific qualifications and periodic requalifications.
- In addition to those regular tests, our quality departement launches regular accelerated tests to further deepens our reliability datas.
- Tests and qualifications of our standard products are based on AECQ methodology and are qualified according to the following limits.
- In accordance to AECQ methodology, specifics tests and limits can be adapted to fit our clients' needs.
- A whole range of stricter reliability tests can be offered for high Reliability products (burn-in, shocks, pulses...) for medical, space and defense applications.
- Based on our reliability database, FIT datas can be provided if necessary.

PRODUCTION CONTROL

Test conducted on each lot according to AECQ-200 framework

FREQUENCY	TEST/STRESS	REFERENCE	AEC-Q	DETAIL
100%	Capa, DF, IR	CECC-32100-4.6		according to datasheet
100%	Visual	CECC-32100-4.5	AEC-Q200-9	no visual defects
50/lot	DPA		AEC-Q200-5	internal component integrity
5/lot	Dimension	CECC-32100-4.5	AEC-Q200-5	according to datasheet
5/lot	Resistance to soldering heat	CECC-32100-4.10	AEC-Q200-15	
5/lot	Solderability	CECC-32100-4.11	AEC-Q200-18	
10/lot	Voltage proof	CECC-32100-4.6.4		
1/ceramic lot	Temperature coefficient	CECC 32100-Prgph4,7		according to datasheet

QUALIFICATIONS

Each component family has been qualified according to CECC and AECQ tests methodology, which are renewed on a periodic basis.

FREQUENCY	TEST/STRESS	REFERENCE	AEC-Q	DETAIL
Qualif	Electrical Characterization	CECC-32100-4.6 4.7	AEC-Q200-19	measure before test according to datasheet and after test according to post environmental limits
Qualif	Temperature Cycling	JESD22 Method-JA method 104	AEC-Q200-4	1,000 cycles -55°C to +125°C Measurement at 24 ± 2 hours after test conclusion
Qualif	Biased Humidity	MIL-STD-202 Method 103	AEC-Q200-7	1,000 hours 85°C/85%RH. Rated voltage. Measurement at 24 ± 2 hours after test conclusion
Qualif	Operational Life	MIL-STD-202 Method 108 condition D	AEC-Q200-8	1,000 hours at 125°C with applied Voltage : 2xRV RV≤500V, 1.2xRV 500V<RV≤1250V, RV RV>1250V
Qualif	High Temperature Exposure (Storage)	MIL-STD-202 Method 108	AEC-Q200-3	1,000 hours at 150°C with 0V. Measurement at 24 ± 2 hours after test conclusion
Qualif	Terminal Strength	CECC-32100-4.8	AEC-Q200-6	1.8kg 60 seconds
Qualif	Vibration	MIL-STD-202 Method 204	AEC-Q200-14	5g 20min 12cycles 3 orientations 10-2000Hz
Qualif	Board Flex	CEC 32100-4.9	AEC-Q200-21	3mm Type 1, 2mm Type 2, Measurement at 24 ± 2 hours after test conclusion

POST ENVIRONMENTAL STRESS LIMIT

DIELECTRIC	DISSIPATION FACTOR (MAXIMUM)	CAPACITANCE SHIFT	INSULATION RESISTANCE
NPO	≤ 4 10 ⁻³	±2%	10% initial limit
N2T	≤ 6 10 ⁻³	±4%	10% initial limit
X7R	≤ 0.035	±15%	10% initial limit

SPACE LEVEL COMPONENT SCREENED AND QUALIFIED ACCORDING TO ESCC-3009

SRT-Microcéramique can propose a wide range of BME and PME component qualified and tested according to ESCC-3009 standard for space projects. Both for development en evaluation (D32) and flight ready with full lot validation and ESCC standard documentation. Specific qualification programmes can be included to meet final customer requirement.

PRODUCTION CONTROL/SCREENING

Tests conducted on each lot and screening for evaluation components D3009CEM and flying components D3009CFM

FREQUENCY	TEST/STRESS	REFERENCE	DETAIL
Lot	DPA	ESCC-23400	Construction analysis
3/Lot	Dimension/weight	ESCC-20400/20500	Dimension in spec/max weight in spec
100%	Burn-In Non serialized	ESCC-3009	168H, max T°, 2Ur Ur<500V, 1.5Ur Ur=500V, 1.3Ur 500V<Ur≤1250V, 1Ur Ur>1250V (fail<5%)
100%	Room Temperature Electrical Measurements	ESCC-3009	Cp, DF, IR, VP according to datasheet
5/lot	High and Low Temperatures Electrical Measurements	ESCC-3009	0 fail
100%	Visual Inspection	ESCC-20400/20500	

LOT VALIDATION

Lot validation for flying components D3009CFM

FREQUENCY	TEST/STRESS	REFERENCE	DETAIL
20/Lot	PCB Mounting, Rapid Change of Temperature, Steady State Humidity, external visual inspection	ESCC-3009/ IEC 60384-1/IEC 60068-2-14	
20/Lot	PCB Mounting, Life test	ECSS-3009/IEC 60384-1	1000H, max T°, 2Ur Ur<500V, 1.5Ur Ur=500V, 1.3Ur 500V<Ur≤1250V, 1Ur Ur>1250V
6/Lot	PCB Mounting, Temperature Characterisation, Robustness of Terminations	ESCC-3009/ IEC 60068-2-14/IEC 60384-1	
6/Lot	Solderability, Permanence of Marking	ECSS-3009/ IEC 60068-2-58/ ECSS-24800	

SPACE LEVEL COMPONENT SCREENED ACCORDING TO COTS+ ECSS-Q-ST-60-13C-REV1

SRT-Microcéramique can apply the COTS+ qualification framework to any suitable component AEQ-200 or not, to make them fly ready, offering a wide range of possibilities at competitive cost, either in Class 1 (COTS1), Class 2 (COTS2) or Class 3 (COTS3).

EVALUATION/SCREENING/LAT

Class 1 (COTS1), Class 2 (COTS2), Class 3 (COTS3)

AECQ-200	CLASS 1	CLASS 2	CLASS 3	CATEGORY	TEST TYPE	SAMPLE	PROCEDURE
Yes	X	X	X	Evaluation	Construction Analysis	5	ESCC21001
Yes	X	X	X	Evaluation	Temperature characterization	5	ESCC3009 8.10
Yes	X			Evaluation	Life Test 2000h	40	ESCC3009 8.6 + 8.9
Yes	X			Screening	Complete screening	100%	ESCC3009 chart F3
Yes	X	X	X	LAT	DPA	3	ESCC21001
Yes	X	X		LAT	Life Test 1000h	20	ESCC3009 8.6 + 8.9
No	X	X	X	Evaluation	Construction Analysis	5	ESCC21001
No	X	X	X	Evaluation	Temperature characterization	5	ESCC 3009 8.10
No	X	X		Evaluation	Complete evaluation	72	ESCC 3009 chart F4
No			X	Evaluation	Life Test 1000h	40	ESCC3009 8.6 + 8.9
No	X	X	X	Screening	Complete screening	100%	ESCC3009 chart F3
No	X	X	X	LAT	DPA	3	ESCC21001
No	X			LAT	Complete LAT	52	ESCC 3009 chart F4
No		X	X	LAT	Life Test 1000h	20	ESCC3009 8.6 + 8.9

TINNING

All component for space application can be proposed with dipped SnPb termination (Sn62 Pb36 Ag2) or SAC 305 (Sn96.5 Ag3 Cu0.5) for maximum reliability and whiskers avoidance.

This document is subject to change without notice.

PME (Precious Metal Electrodes)

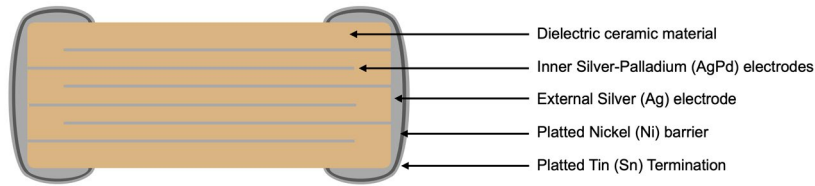

PME (Precious Metal Electrodes) Polymer Soft Termination

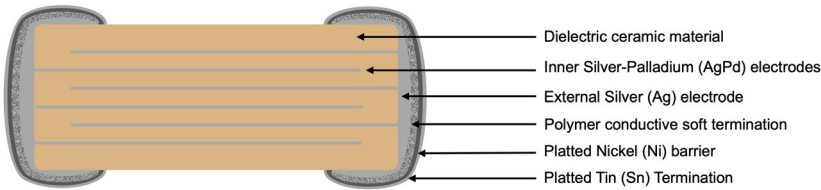

PME (Precious Metal Electrodes) Non Magnetic

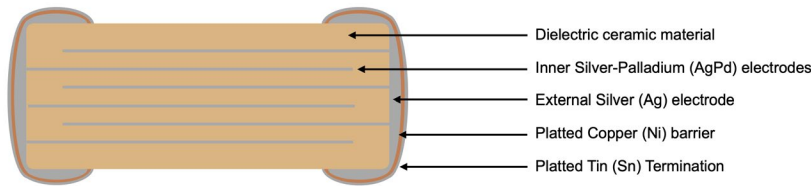

BME (Basis Metal Electrodes) code BM

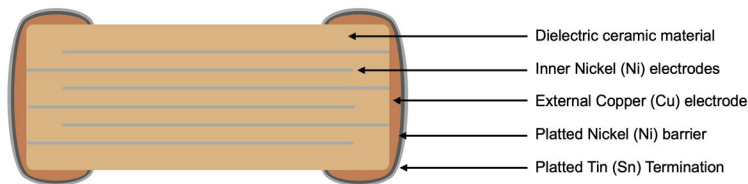

BME (Basis Metal Electrodes) code BM Polymer Soft Termination

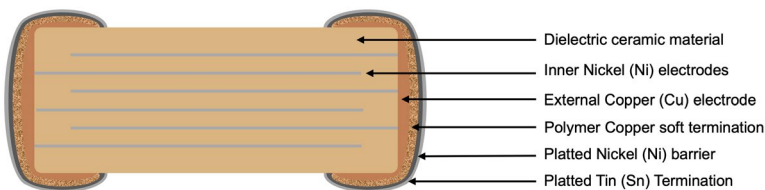

REACH Compliance

- SRT-Microcéramique delivers non-chemical articles only.
- These contain no substances which are intended to be released under normal or reasonably foreseeable conditions of use according to Reach article 7(1).

SRT-Microcéramique confirms hereby that our products contain none of the substances which are listed in the present candidate list of the European Chemicals Agency (ECHA), above a concentration of 0.1% by weight of the whole component.

Candidate list of substances (European Chemicals Agency ECHA) :
<http://echa.europa.eu/fr/candidate-list-table>

ROHS COMPLIANCE

SRT-Microcéramique herewith confirms that RoHS-compliant SRT-microcéramique products are conforming to the following EU directives:
EU directive 2015/863/EU EU directive 2011/65/EU EU directive 2003/11/EC

Following restricted materials are not used and do not exceed the legal limits: Lead (Pb, see exemptions),

- Mercury (Hg)
- Cadmium (Cd)
- Chromium (Cr VI)
- Polybrominated biphenyls (PBB) Polybrominated diphenyl ethers (PBDE) Bis(2-Ethylhexyl) phthalate (DEHP) Benzyl butyl phthalate (BBP)
- Dibutyl phthalate (DBP) Diisobutyl phthalate (DIBP)

Exemptions: The following exemptions according to the RoHS annexe are applicable:

Identity 7(a) :

- Lead in high melting temperature type solders (i.e lead-based alloys containing 85% by weight or more lead).

Identity 7(c)-I :

- Electrical and electronic components containing lead in a glass or ceramic other than dielectric ceramic capacitors, e.g. piezoelectronic devices, or in a glass or ceramic matrix compound.

The components are suitable for a lead-free process according to EN 60068-2-58 and in accordance with the IPC/JEDEC standard J-Std-020D. The lead free process has been tested using solder alloy Sn96.5Ag3Cu0.5

Export controls and dual-use regulations

Some SRT-Microcéramique components fall under 'dual-use' items under international export controls definition - those that can be used for civil or military purposes which meet certain specified technical standards.

The defining criteria for a dual use component is one with a voltage rating of >750Vdc and a capacitance value of >250nF when measured at 750Vdc and a series inductance <10nH. Components defined as dual-use under the above criteria may require a licence for export across international borders. Please contact us for further information on specific part numbers.

ISO9001:2015

In their design, research and development as well as the manufacturing of MLCC capacitors, customer service and distribution SRT-Microcéramique uses and maintains a Management System audited and certified in accordance to : **ISO9001:2015**

You may contact us for any inquiry regarding the regulations and compliance listed above.

SMD Low Voltage Class I

10V - 1000V



SRT
MICROCÉRAMIQUE
MLCC CAPACITORS

APPLICATIONS

- Typical uses : timing, precision circuitry, filtering

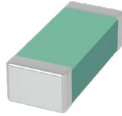

RoHS compliant

FEATURES

- Ultra stable temperature compensating classe I ceramic
- Custom voltage, package size, capacitance value on request
- Tested in accordance to CECC 32100 and AEC-Q200
- CECC 30600 et NFC 83-131 compliant
- Available in stack or radial
- Wide range of termination
- All PME SMD available in non magnetic

ELECTRICAL PARAMETERS

ELECTRICAL CHARACTERISTICS :
at + 25°C unless otherwise specified

OPERATING TEMPERATURE :
- 55°C, + 125°C

TEMPERATURE COEFFICIENT :
± 30ppm with 0Vdc applied

DISSIPATION FACTOR :
≤ 1.10-3 at 1Vrms and 1MHz for values ≤ 1000pF
≤ 1.10-3 at 1Vrms and 1KHz for values > 1000pF

INSULATION RESISTANCE (IR) :
25°C/Un 10⁵ MOhm or 1000 Ohm-Farad whichever is less
125°C/Un 10⁴ MOhm or 100 Ohm-Farad whichever is less

DIELECTRIC STRENGTH TEST :
2.5Un U≤200V | U+250V 200<U≤500 | 1.5U 500<U<1000 | 1.2U U≥1000
for 5s with 50mA max charging current

QUICK REFERENCE DATA

	0201	0402	0504	0603	0805	1206	1210	1808	1812	1825	2220	2225	2825	3033	3640	4040	5440
Min	0.1 pF	0.1 pF	0.1 pF	0.1 pF	0.1 pF	0.4 pF	0.4 pF	1.0 pF	1.0 pF	1.0 pF	1.0 pF	1.0 pF	4.7 pF	10 pF	10 pF	10 pF	10 pF
10V	1.0 nF	2.2 nF	1.5 nF	27 nF	47 nF	220 nF	220 nF	22 nF	220 nF	100 nF	470 nF	100 nF	120 nF	150 nF	220 nF	270 nF	330 nF
25V	1.0 nF	2.2 nF	1.5 nF	27 nF	47 nF	220 nF	220 nF	22 nF	220 nF	100 nF	470 nF	100 nF	120 nF	150 nF	220 nF	270 nF	330 nF
50V	220 pF	1.5 nF	1.5 nF	10 nF	47 nF	220 nF	150 nF	22 nF	220 nF	100 nF	470 nF	100 nF	120 nF	150 nF	220 nF	270 nF	330 nF
63V	100 pF	1.0 nF	1.5 nF	10 nF	33 nF	100 nF	100 nF	22 nF	150 nF	100 nF	330 nF	100 nF	120 nF	150 nF	220 nF	270 nF	330 nF
100V	100 pF	1.0 nF	1.5 nF	10 nF	33 nF	100 nF	100 nF	22 nF	150 nF	100 nF	330 nF	100 nF	120 nF	150 nF	220 nF	270 nF	330 nF
200V		330 pF	1.2 nF	2.2 nF	10 nF	22 nF	47 nF	22 nF	100 nF	82 nF	150 nF	100 nF	120 nF	150 nF	220 nF	270 nF	330 nF
250V		330 pF	1.2 nF	2.2 nF	10 nF	22 nF	47 nF	22 nF	100 nF	82 nF	150 nF	100 nF	120 nF	150 nF	220 nF	270 nF	330 nF
500V		180 pF	1.0 nF	1.0 nF	3.3 nF	8.2 nF	15 nF	18 nF	33 nF	68 nF	68 nF	82 nF	120 nF	150 nF	220 nF	270 nF	330 nF
630V				560 pF	2.2 nF	6.8 nF	12 nF	15 nF	27 nF	56 nF	56 nF	68 nF	82 nF	120 nF	180 nF	220 nF	270 nF
1000V				220 pF	820 pF	2.7 nF	6.8 nF	6.8 nF	15 nF	33 nF	39 nF	47 nF	56 nF	82 nF	120 nF	120 nF	180 nF

Max values italic obtained with BME parts

ORDERING INFORMATION

0603	A	101	J	B	X	B	-
SIZE	DIELECTRIC	CAPACITANCE	TOLERANCE	VOLTAGE	TERMINATION	PACKAGING	SPECIAL PARAMETERS
0201 0402 0504 0603 0805 1206 1210 1808 1812 1825 2220 2225 2825 3033 3640 4040 5440	A = NPO	Expressed in picofarads (pF). The first two digits are significant, the third digit gives the number of noughts. Example : 102 = 1 000pF For special values R is used as decimal separator Example 12R7 = 12.7pF 1340R0 = 1340pF	A = ±0,5% if > 10pF and ±0,05pF if < 10pF B = ± 0.1pF C = ± 0,25pF D = ± 0,5pF E = 0.1% F = ± 1% G = ± 2% J = ± 5% K = ± 10%	Q = 10V J = 16V X = 25V A = 50V U = 63V B = 100V C = 200V P = 250V E = 500V F = 630V G = 1000V	X = Nickel Tin F = Palladium-Silver P = Polymer Tin (Flex) C = Copper Tin (Non magnetic) W = Nickel Gold H = Dipped SnPb I = Electrolytic SnPb Q = Solderable Silver	B = Reel V = Bulk	- BM = BME Dxx = Reliability spec Exx = Sorting spec D20 = AECQ-200

For other sizes, voltage, tolerance contact us.

DIMENSIONS IN MILLIMETERS

	0201	0402	0504	0603	0805	1206	1210	1808	1812	1825	2220	2225	2825	3033	3640	4040	5440
Length (L)	0.60 ± 0.03	1.00 ± 0.1	1.25 ± 0.1	1.60 ± 0.2	2.00 ± 0.2	3.20 ± 0.2	3.20 ± 0.2	4.60 ± 0.3	4.60 ± 0.3	4.60 ± 0.4	5.60 ± 0.4	5.60 ± 0.4	7.10 ± 0.4	7.60 ± 0.4	9.15 ± 0.8	10.20 ± 0.8	13.70 ± 1.0
Width (W)	0.30 ± 0.03	0.50 ± 0.1	1.00 ± 0.1	0.80 ± 0.2	1.25 ± 0.2	1.60 ± 0.2	2.50 ± 0.2	2.00 ± 0.2	3.20 ± 0.2	6.35 ± 0.3	5.10 ± 0.4	6.35 ± 0.4	6.35 ± 0.4	8.40 ± 0.4	10.20 ± 0.8	10.20 ± 0.8	10.20 ± 1.0
Thickness max(T)	0.35	0.60	1.00	0.92	1.40	1.70	2.50	2.20	3.30	3.60	4.00	4.00	4.00	4.00	4.00	4.00	4.00
Termination (P)																	
Min	0.10	0.10	0.10	0.25	0.25	0.25	0.25	0.25	0.25	0.25	0.25	0.25	0.25	0.50	0.80	0.80	0.80
Max	0.20	0.40	0.40	0.40	0.70	0.70	0.80	0.80	0.80	0.80	0.80	1.00	1.00	1.20	1.50	1.50	1.50

For P termination (Polymer type) add 0.10mm to Length (L) and 0.05 to Width (W)

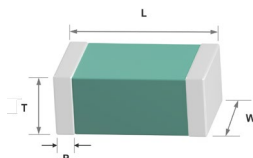

This document is subject to change without notice.



STANDARD SIZE : 0201 to 1808

SIZE	CAP	0201			0402				0504				0603				0805				1206				1210				1808			
		10V	50V	100V	10V	25V	50V	100V	250V	500V	25V	50V	100V	250V	500V	1000V	25V	50V	100V	250V	500V	1000V	25V	50V	100V	250V	500V	1000V				
OR1	0.1 pF	●	●	●																												
OR3	0.3 pF	●	●	●																												
OR5	0.5 pF	●	●	●																												
OR8	0.8 pF	●	●	●																												
1R0	1.0 pF	●	●	●																												
1R2	1.2 pF	●	●	●																												
1R5	1.5 pF	●	●	●																												
1R8	1.8 pF	●	●	●																												
2R2	2.2 pF	●	●	●																												
2R7	2.7 pF	●	●	●																												
3R3	3.3 pF	●	●	●																												
3R9	3.9 pF	●	●	●																												
4R7	4.7 pF	●	●	●																												
5R6	5.6 pF	●	●	●																												
6R8	6.8 pF	●	●	●																												
8R2	8.2 pF	●	●	●																												
100	10 pF	●	●	●																												
120	12 pF	●	●	●																												
150	15 pF	●	●	●																												
180	18 pF	●	●	●																												
220	22 pF	●	●	●																												
270	27 pF	●	●	●																												
330	33 pF	●	●	●																												
390	39 pF	●	●	●																												
470	47 pF	●	●	●																												
560	56 pF	●	●	●																												
680	68 pF	●	●	●																												
820	82 pF	●	●	●																												
101	100 pF	●	●	●																												
121	120 pF	●	●	●																												
151	150 pF	●	●	●																												
181	180 pF	●	●	●																												
221	220 pF	●	●	●																												
271	270 pF	●	●	●																												
331	330 pF	●	●	●																												
391	390 pF	●	●	●																												
471	470 pF	●	●	●																												
561	560 pF	●	●	●																												
681	680 pF	●	●	●																												
821	820 pF	●	●	●																												
102	1.0 nF	●	●	●																												
122	1.2 nF	●	●	●																												
152	1.5 nF	●	●	●																												
182	1.8 nF	●	●	●																												
222	2.2 nF	●	●	●																												
272	2.7 nF	●	●	●																												
332	3.3 nF	●	●	●																												
392	3.9 nF	●	●	●																												
472	4.7 nF	●	●	●																												
562	5.6 nF	●	●	●																												
682	6.8 nF	●	●	●																												
822	8.2 nF	●	●	●																												
103	10 nF	●	●	●																												
123	12 nF	●	●	●																												
153	15 nF	●	●	●																												
183	18 nF	●	●	●																												
223	22 nF	●	●	●																												
273	27 nF	●	●	●																												
333	33 nF	●	●	●																												
393	39 nF	●	●	●																												
473	47 nF	●	●	●																												
563	56 nF	●	●	●																												
683	68 nF	●	●	●																												
823	82 nF	●	●	●																												
104	100 nF	●	●	●																												
124	120 nF	●	●	●																												
154	150 nF	●	●	●																												
184	180 nF	●	●	●																												
224	220 nF	●	●	●																												
274	270 nF	●	●	●																												
334	330 nF	●	●	●																												
394	390 nF	●	●	●																												
474	470 nF	●	●	●																												
564	560 nF	●	●	●																												
684	680 nF	●	●	●																												
824	820 nF	●	●	●																												

● BME parts

This document is subject to change without notice.





TYPICAL CHARACTERISTICS

NPO Temperature coefficient of capacitance

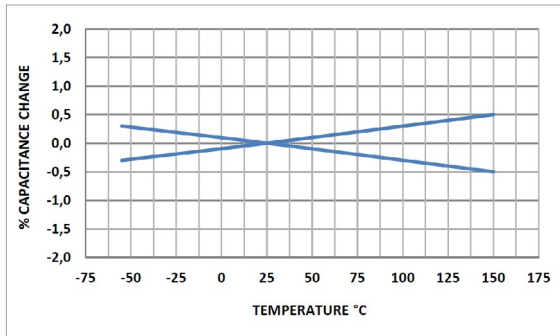

NPO Insulation resistance vs. temperature

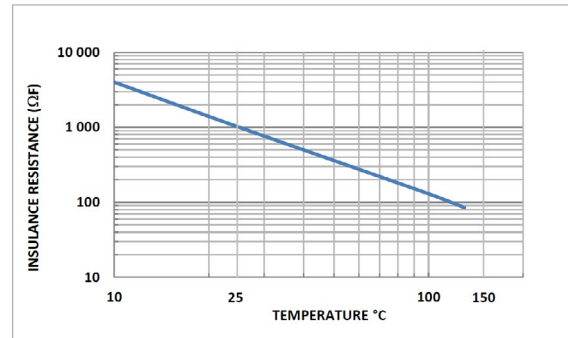

NPO Aging rate

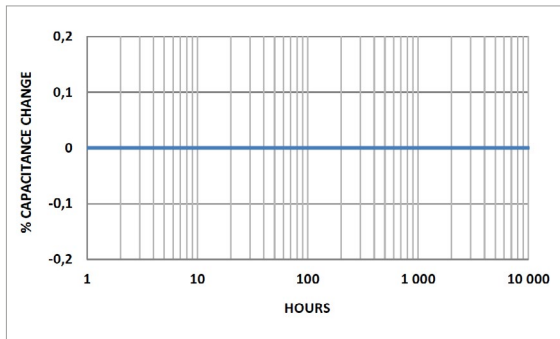

NPO Voltage coefficient of capacitance

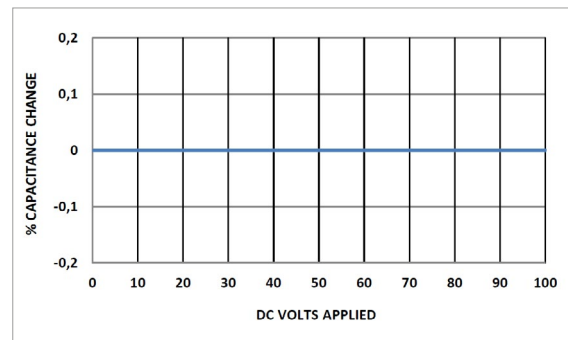

NPO Change of Capacitance with Frequency

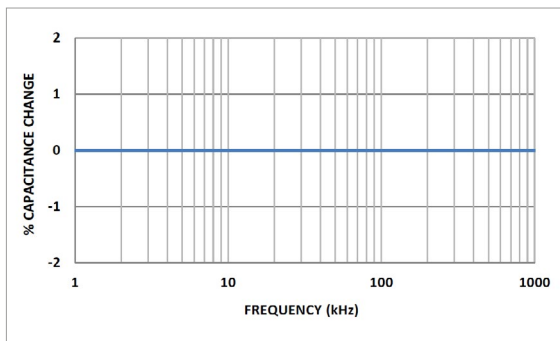

NPO Dissipation factor vs. frequency

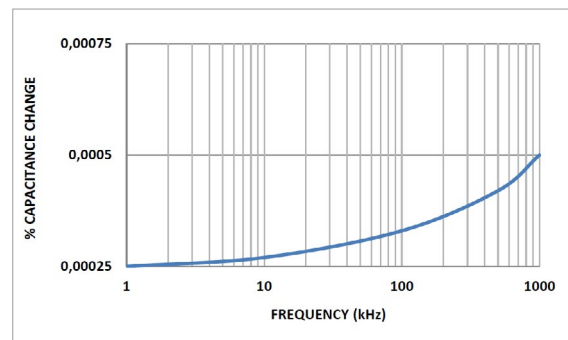



APPLICATIONS

- Typical uses : timing, filtering, pulse discharge

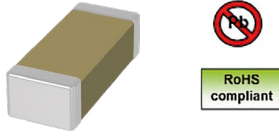

FEATURES

- Class 1,5
- Close to Class 1 stability, high power
- No piezo electric effect, high current pulse discharge
- Custom voltage, package size, capacitance value on request
- Available in stack or radial
- Wide range of termination
- All PME SMD available in non magnetic termination

ELECTRICAL PARAMETERS

ELECTRICAL CHARACTERISTICS :
at + 25°C unless otherwise specified

OPERATING TEMPERATURE :
- 55°C, + 125°C

TEMPERATURE COEFFICIENT :
-2200 ± 350 ppm/C° with 0Vdc applied

DISSIPATION FACTOR :
≤ 1.10-3 at 1Vrms and 1MHz for values ≤ 1000pF
≤ 1.10-3 at 1Vrms and 1KHz for values > 1000pF

INSULATION RESISTANCE (IR) :
25°C/Un 10⁵ MOhm or 1000 Ohm-Farad whichever is less
125°C/Un 10⁴ MOhm or 100 Ohm-Farad whichever is less

DIELECTRIC STRENGTH TEST :
2.5Un U≤200V | U+250V 200<U≤500 | 1.5U 500<U<1000 | 1.2U U≥1000
for 5s with 50mA max charging current

QUICK REFERENCE DATA

	0402	0504	0603	0805	1206	1210	1808	1812	1825	2220	2225	2825	3033	3640	4040	5440
Min	0.3 pF	0.3 pF	0.3 pF	1.0 pF	4.7 pF	4.7 pF	4.7 pF	4.7 pF	10 pF	10 pF	10 pF	10 pF	47 pF	47 pF	47 pF	47 pF
10V	1.2 nF	39 nF	1.5 nF	15 nF	220 nF	15 nF	82 nF	820 nF	82 nF	330 nF	2.2 μF	120 nF	680 nF	820 nF	5.6 μF	330 nF
25V	1.2 nF	39 nF	1.5 nF	15 nF	220 nF	15 nF	82 nF	820 nF	82 nF	330 nF	2.2 μF	120 nF	680 nF	820 nF	5.6 μF	330 nF
50V	1.2 nF	39 nF	1.2 nF	15 nF	220 nF	15 nF	82 nF	820 nF	82 nF	330 nF	2.2 μF	120 nF	680 nF	820 nF	5.6 μF	330 nF
63V	1.2 nF	39 nF	1.2 nF	15 nF	220 nF	15 nF	82 nF	820 nF	82 nF	330 nF	2.2 μF	120 nF	680 nF	820 nF	5.6 μF	330 nF
100V	1.2 nF	39 nF	1.2 nF	15 nF	220 nF	15 nF	82 nF	820 nF	82 nF	330 nF	2.2 μF	120 nF	680 nF	820 nF	5.6 μF	330 nF
200V	1.0 nF	39 nF	1.2 nF	15 nF	220 nF	15 nF	82 nF	820 nF	82 nF	330 nF	2.2 μF	120 nF	680 nF	820 nF	5.6 μF	330 nF
250V	1.0 nF	33 nF	1.2 nF	15 nF	220 nF	15 nF	82 nF	820 nF	82 nF	330 nF	2.2 μF	120 nF	680 nF	820 nF	5.6 μF	330 nF
500V	330 pF	6.8 nF	1.0 nF	6.8 nF	82 nF	15 nF	47 nF	330 nF	68 nF	180 nF	1.0 μF	120 nF	390 nF	560 nF	2.7 μF	330 nF
630V			560 pF	4.7 nF	47 nF	12 nF	39 nF	270 nF	56 nF	150 nF	820 nF	82 nF	330 nF	470 nF	2.2 μF	270 nF
1000V			220 pF	1.8 nF	15 nF	6.8 nF	15 nF	120 nF	33 nF	100 nF	470 nF	56 nF	220 nF	330 nF	1.2 μF	180 nF

ORDERING INFORMATION

0805	P	101	J	A	X	B	-
SIZE	DIELECTRIC	CAPACITANCE	TOLERANCE	VOLTAGE	TERMINATION	PACKAGING	SPECIAL PARAMETERS
0201 0402 0504 0603 0805 1206 1210 1808 1812 1825 2220 2225 2825 3033 3640 4040 5440	P = N2T	Expressed in picofarads (pF). The first two digits are significant, the third digit gives the number of noughts. Example : 102 = 1 000pF For special values R is used as decimal separator Example 12R7 = 12.7pF 1340R0 = 1340pF	A = ±0.05pF if < 10pF and 0.05% if > 10pF B = ± 0.1pF C = ± 0,25pF D = ± 0,5pF F = ± 1% G = ± 2% J = ± 5% K = ± 10%	Q = 10V X = 25V A = 50V U = 63V B = 100V C = 200V P = 250V E = 500V F = 630V G = 1000V	X = Nickel Tin F = Palladium-Silver P = Polymer Tin (Flex) C = Copper Tin (Non magnetic) W = Nickel Gold H = Dipped SnPb I = Electrolytic SnPb Q = Solderable Silver	B = Reel V = Bulk	- Dxx = Reliability spec Exx = Sorting spec

For other sizes, voltage, tolerance contact us.

DIMENSIONS IN MILLIMETERS

	0402	0504	0603	0805	1206	1210	1808	1812	1825	2220	2225	2825	3033	3640	4040	5440
Length (L)	1.00 ± 0.1	1.25 ± 0.1	1.60 ± 0.2	2.00 ± 0.2	3.20 ± 0.2	3.20 ± 0.2	4.60 ± 0.3	4.60 ± 0.3	4.60 ± 0.4	5.60 ± 0.4	5.60 ± 0.4	7.10 ± 0.4	7.60 ± 0.4	9.15 ± 0.8	10.20 ± 0.8	13.70 ± 1.0
Width (W)	0.50 ± 0.1	1.00 ± 0.1	0.80 ± 0.2	1.25 ± 0.2	1.60 ± 0.2	2.50 ± 0.2	2.00 ± 0.2	3.20 ± 0.2	6.35 ± 0.3	5.10 ± 0.4	6.35 ± 0.4	6.35 ± 0.4	8.40 ± 0.4	10.20 ± 0.8	10.20 ± 0.8	10.20 ± 1.0
Thickness max(T)	0.60	1.00	0.92	1.40	1.70	2.50	2.20	3.30	3.60	4.00	4.00	4.00	4.00	4.00	4.00	4.00
Termination (P)	Min	0.10	0.10	0.25	0.25	0.25	0.25	0.25	0.25	0.25	0.25	0.25	0.50	0.80	0.80	0.80
	Max	0.40	0.40	0.40	0.70	0.70	0.80	0.80	0.80	1.00	1.00	1.00	1.20	1.50	1.50	1.50

For P termination (Polymer type) add 0.10mm to Length (L) and 0.05 to Width (W)

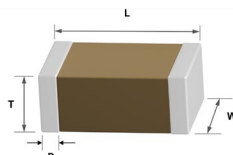

This document is subject to change without notice.

SMD Low Voltage N2T

10V - 1000V



STANDARD SIZE : 1825 to 5440

SIZE	1825						2220						2225						3033						3640						4040						5440					
	CODE	CAP	25V	50V	63V	100V	250V	500V	630V	1000V	25V	50V	63V	100V	250V	500V	630V	1000V	25V	50V	63V	100V	250V	500V	630V	1000V	25V	50V	63V	100V	250V	500V	630V	1000V								
100	10 pf																																									
120	12 pf																																									
150	15 pf																																									
180	18 pf																																									
220	22 pf																																									
270	27 pf																																									
330	33 pf																																									
390	39 pf																																									
470	47 pf																																									
560	56 pf																																									
680	68 pf																																									
820	82 pf																																									
101	100 pf																																									
121	120 pf																																									
151	150 pf																																									
181	180 pf																																									
221	220 pf																																									
271	270 pf																																									
331	330 pf																																									
391	390 pf																																									
471	470 pf																																									
561	560 pf																																									
681	680 pf																																									
821	820 pf																																									
102	1.0 nf																																									
122	1.2 nf																																									
152	1.5 nf																																									
182	1.8 nf																																									
222	2.2 nf																																									
272	2.7 nf																																									
332	3.3 nf																																									
392	3.9 nf																																									
472	4.7 nf																																									
562	5.6 nf																																									
682	6.8 nf																																									
822	8.2 nf																																									
103	10 nf																																									
123	12 nf																																									
153	15 nf																																									
183	18 nf																																									
223	22 nf																																									
273	27 nf																																									
333	33 nf																																									
393	39 nf																																									
473	47 nf																																									
563	56 nf																																									
683	68 nf																																									
823	82 nf																																									
104	100 nf																																									
124	120 nf																																									
154	150 nf																																									
184	180 nf																																									
224	220 nf																																									
274	270 nf																																									
334	330 nf																																									
394	390 nf																																									
474	470 nf																																									
564	560 nf																																									
684	680 nf																																									
824	820 nf																																									
105	1.0 μF																																									
125	1.2 μF																																									
155	1.5 μF																																									
185	1.8 μF																																									
225	2.2 μF																																									
275	2.7 μF																																									
335	3.3 μF																																									
395	3.9 μF																																									
475	4.7 μF																																									
565	5.6 μF																																									
685	6.8 μF																																									
825	8.2 μF																																									
106	10 μF																																									
126	12 μF																																									
156	15 μF																																									



TYPICAL CHARACTERISTICS

N2T Capacitance vs. temperature

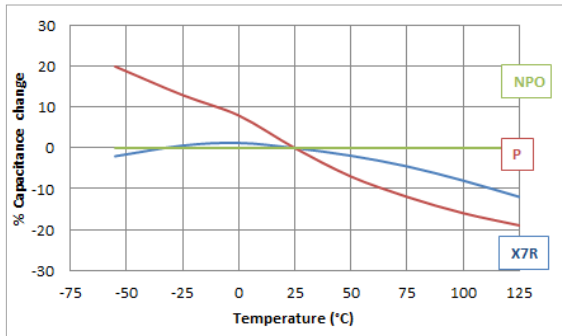

N2T Dissipation factor vs. temperature

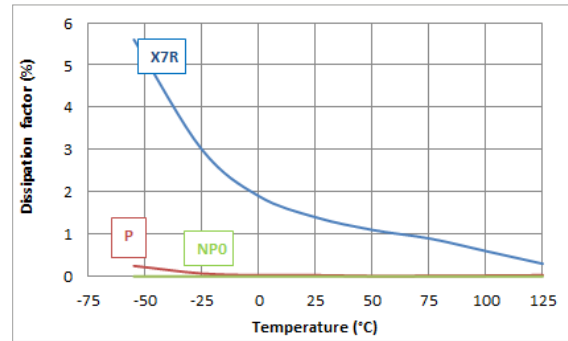

N2T Capacitance vs. voltage

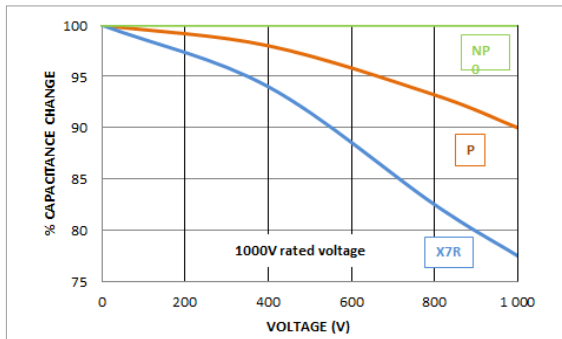

SMD Low Voltage Class II

10V - 1000V



SRT
MICROCÉRAMIQUE
MLCC CAPACITORS

APPLICATIONS

- Typical uses : passing, coupling, filtering, blocking

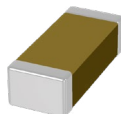

FEATURES

- Temperature stable classe II ceramic
- Custom voltage, package size, capacitance value on request
- Tested in accordance to CECC 32100 and AEC-Q200
- CECC 30700 et NFC 83-132 compliant
- Available in stack or radial
- Wide range of termination
- All PME values available in non magnetic termination
- BX range with improved ESR and voltage coef, MIL specifications

ELECTRICAL PARAMETERS

ELECTRICAL CHARACTERISTICS :
at + 25°C unless otherwise specified

OPERATING TEMPERATURE :
- 55°C, + 125°C

TEMPERATURE COEFFICIENT :
± 15% with 0Vdc applied
BX : +15% -25% at rated voltage

DISSIPATION FACTOR :
≤ 2.5% at 1kHz for C ≥ 100pF

INSULATION RESISTANCE (IR) :
25°C/Un 10⁵ MOhm or 1000 Ohm-Farad whichever is less
125°C/Un 10⁴ MOhm or 100 Ohm-Farad whichever is less

DIELECTRIC STRENGTH TEST :
2.5Un U ≤ 200V | U + 250V 200 < U ≤ 500 | 1.5U 500 < U < 1000 | 1.2U U ≥ 1000
for 5s with 50mA max charging current

QUICK REFERENCE DATA

	0201	0402	0504	0603	0805	1206	1210	1808	1812	1825	2220	2225	2825	3033	3640	4040	5440
Min	100 pF	2.2 pF	2.2 pF	2.2 pF	6.8 pF	10 pF	10 pF	10 pF	10 pF	33 pF	33 pF	33 pF	33 pF	100 pF	100 pF	100 pF	100 pF
10V	33 nF	470 nF	39 nF	4.7 μF	10 μF	22 μF	47 μF	470 nF	22 μF	10 μF	47 μF	10 μF	2.7 μF	3.9 μF	5.6 μF	5.6 μF	8.2 μF
25V	10 nF	220 nF	39 nF	1.0 μF	4.7 μF	10 μF	47 μF	470 nF	22 μF	10 μF	47 μF	10 μF	2.7 μF	3.9 μF	5.6 μF	5.6 μF	8.2 μF
50V	1.5 nF	100 nF	39 nF	1.0 μF	4.7 μF	10 μF	47 μF	470 nF	6.8 μF	10 μF	47 μF	10 μF	2.7 μF	3.9 μF	5.6 μF	5.6 μF	8.2 μF
63V		12 nF	39 nF	100 nF	1.0 μF	4.7 μF	22 μF	470 nF	4.7 μF	10 μF	22 μF	10 μF	2.7 μF	3.9 μF	5.6 μF	5.6 μF	8.2 μF
100V		10 nF	39 nF	100 nF	1.0 μF	4.7 μF	22 μF	470 nF	4.7 μF	10 μF	22 μF	10 μF	2.7 μF	3.9 μF	5.6 μF	5.6 μF	8.2 μF
200V		6.8 nF	39 nF	39 nF	100 nF	220 nF	390 nF	470 nF	820 nF	1.8 μF	1.8 μF	2.2 μF	2.7 μF	3.9 μF	5.6 μF	5.6 μF	8.2 μF
250V		5.6 nF	33 nF	27 nF	82 nF	220 nF	330 nF	470 nF	820 nF	1.8 μF	1.8 μF	2.2 μF	2.7 μF	3.9 μF	5.6 μF	5.6 μF	8.2 μF
500V		1.2 nF	6.8 nF	6.8 nF	27 nF	82 nF	180 nF	220 nF	330 nF	820 nF	820 nF	1.0 μF	1.2 μF	1.8 μF	2.7 μF	2.7 μF	3.9 μF
630V				3.9 nF	15 nF	47 nF	120 nF	120 nF	270 nF	560 nF	560 nF	820 nF	1.0 μF	1.2 μF	1.8 μF	2.2 μF	2.7 μF
1000V				1.2 nF	5.6 nF	15 nF	47 nF	39 nF	120 nF	330 nF	330 nF	470 nF	560 nF	820 nF	1.2 μF	1.2 μF	1.8 μF

Max values italic obtained with BME parts

ORDERING INFORMATION

0805	Y	103	K	C	X	B	-
SIZE	DIELECTRIC	CAPACITANCE	TOLERANCE	VOLTAGE	TERMINATION	PACKAGING	SPECIAL PARAMETERS
0201 0402 0504 0603 0805 1206 1210 1808 1812 1825 2220 2225 2825 3033 3640 4040 5440	Y = X7R X = BX BY = 2C1	Expressed in picofarads (pF). The first two digits are significant, the third digit gives the number of noughts. Example : 102 = 1 000pF For special values R is used as decimal separator Example 12R7 = 12.7pF 1340R0 = 1340pF	J = ± 5% K = ± 10% M = ± 20%	Q = 10V X = 25V A = 50V U = 63V B = 100V C = 200V P = 250V E = 500V F = 630V G = 1000V	X = Nickel Tin F = Palladium-Silver P = Polymer Tin (Flex) C = Copper Tin (Non magnetic) CP = Copper Polymer Tin (Non magnetic) W = Nickel Gold Flash G = Nickel Gold Thick H = Dipped SnPb S = Dipped SAC SP = Polymer Dipped SAC HP = Polymer Dipped SnPb I = Electrolytic SnPb IP = Polymer Electrolytic SnPb Q = Solderable Silver	B = Reel V = Bulk	- BM = BME Dxx = Reliability spec Exx = Sorting spec

For other sizes, voltage, tolerance contact us.

DIMENSIONS IN MILLIMETERS

	0201	0402	0504	0603	0805	1206	1210	1808	1812	1825	2220	2225	2825	3033	3640	4040	5440
Length (L)	0.60 ± 0.03	1.00 ± 0.1	1.25 ± 0.1	1.60 ± 0.2	2.00 ± 0.2	3.20 ± 0.2	3.20 ± 0.2	4.60 ± 0.3	4.60 ± 0.3	4.60 ± 0.4	5.60 ± 0.4	5.60 ± 0.4	7.10 ± 0.4	7.60 ± 0.4	9.15 ± 0.8	10.20 ± 0.8	13.70 ± 1.0
Width (W)	0.30 ± 0.03	0.50 ± 0.1	1.00 ± 0.1	0.80 ± 0.2	1.25 ± 0.2	1.60 ± 0.2	2.50 ± 0.2	2.00 ± 0.2	3.20 ± 0.2	6.35 ± 0.3	5.10 ± 0.4	6.35 ± 0.4	6.35 ± 0.4	8.40 ± 0.4	10.20 ± 0.8	10.20 ± 0.8	10.20 ± 1.0
Thickness max(T)	0.35	0.60	1.00	0.92	1.40	1.70	2.50	2.20	3.30	3.60	4.00	4.00	4.00	4.00	4.00	4.00	4.00
Termination (P)	Min Max	0.10 0.20	0.10 0.40	0.10 0.40	0.25 0.70	0.25 0.70	0.25 0.80	0.25 0.80	0.25 0.80	0.25 0.80	0.25 0.80	0.25 1.00	0.25 1.00	0.50 1.20	0.80 1.50	0.80 1.50	0.80 1.50

For P termination (Polymer type) add 0.10mm to Length (L) and 0.05 to Width (W)

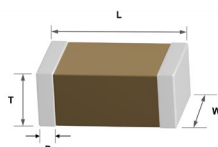

This document is subject to change without notice.



TYPICAL CHARACTERISTICS

X7R Capacitance and dissipation factor vs temperature

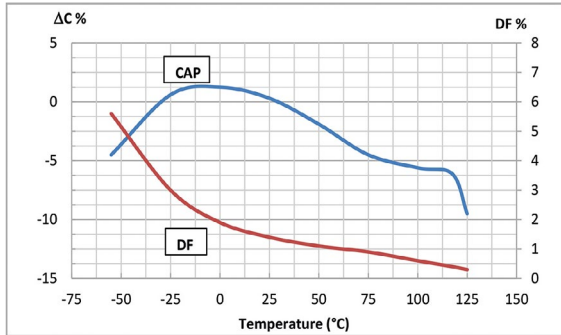

BX Capacitance and dissipation factor vs temperature

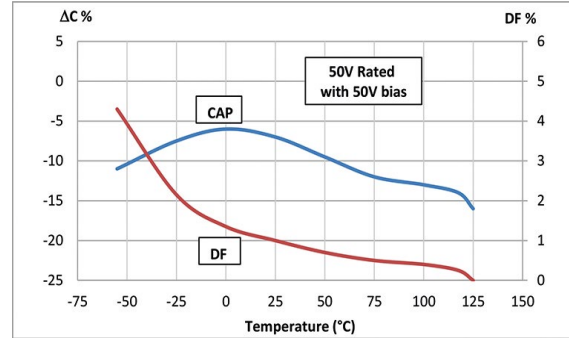

X7R Voltage coefficient of capacitance

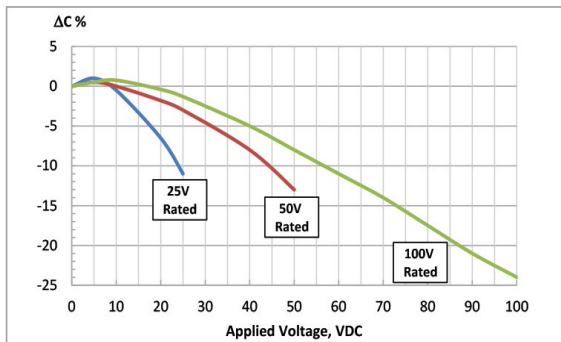

BX Voltage coefficient of capacitance

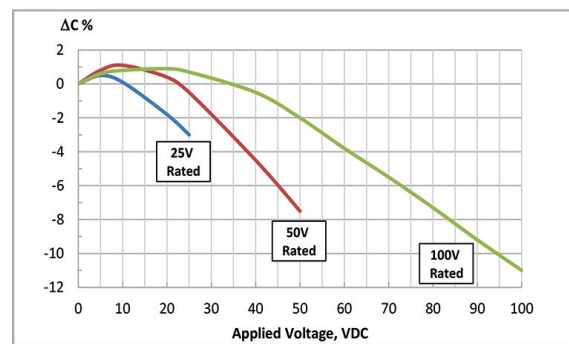

X7R and BX Aging

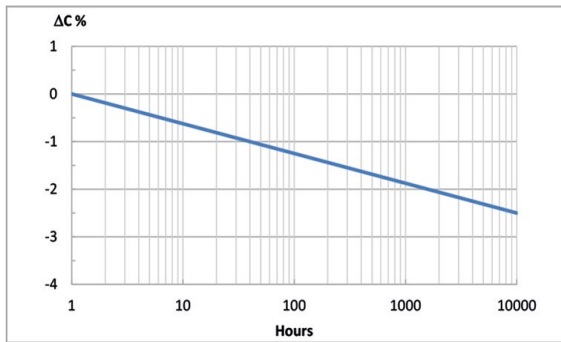

X7R and BX Insulation resistance vs temperature

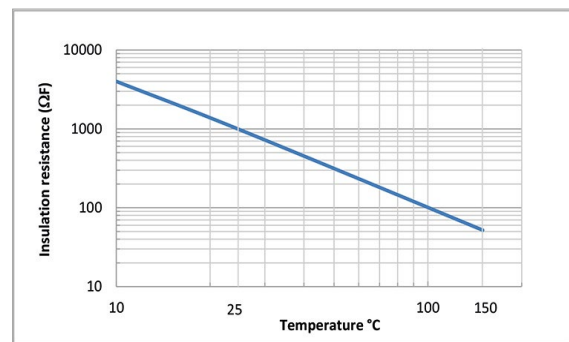

X7R Impedance vs frequency

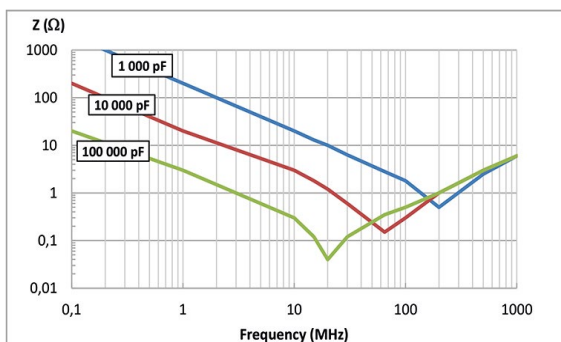

BX Impedance vs frequency

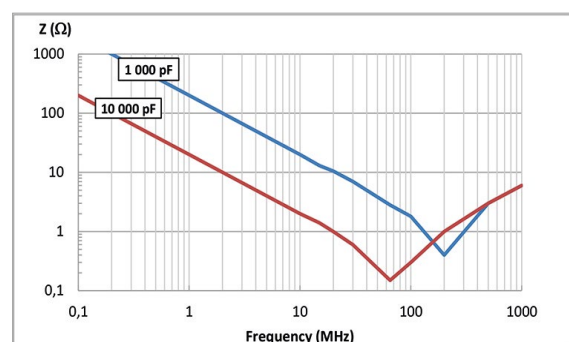

High Capacitance capacitors

X7S X6S X5R Y5V Series



SRT
MICROCÉRAMIQUE
MLCC CAPACITORS

APPLICATIONS

- Digital circuit coupling/decoupling
- High frequency & high-density type power suppliers
- For bypassing
- Ideal for smoothing circuits
- Suitable for DC-DC converter, personal computer and peripherals, telecommunication and general electronic equipment

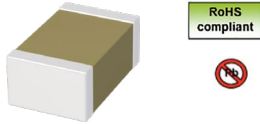

FEATURES

- Realize high capacitance in small sizes
- Capacitor with lead-free termination (pure Tin)
- Basis Metal Electrode
- RoHS and HALOGEN compliant
- Manufactured in Taiwan
- Surface mount suited for wave and reflow soldering
- High reliability and no polarity
- Excellent in high frequency characteristic

ELECTRICAL PARAMETERS

ELECTRICAL CHARACTERISTICS :
at + 25°C unless otherwise specified

OPERATING TEMPERATURE :

X7S : - 55°C, + 125°C
X6S : - 55°C, + 105°C
X5R : - 55°C, + 85°C
Y5V : - 25°C, + 85°C

TEMPERATURE COEFFICIENT :

X7S : ±22% with 0Vdc applied
X6S : ±22% with 0Vdc applied
X5R : ±15% with 0Vdc applied
Y5V : +30% -80% with 0Vdc applied

DISSIPATION FACTOR :

cf Table

INSULATION RESISTANCE (IR) :

25°C/Un 10⁴ MOhm or 500 Ohm-Farad whichever is less
Except ° table 25°C/Un 10⁴ MOhm or 100 Ohm-Farad whichever is less
Except ° table 50 Ohm-Farad

DIELECTRIC STRENGTH TEST :

2.5Un for 5s with 50mA max charging current

QUICK REFERENCE DATA

	0201		0402			0603				0805				1206				1210				1812	
	X7S	X5R	X7S	X6S	X5R	X7S	X6S	X5R	Y5V	X7S	X6S	X5R	Y5V	X7S	X6S	X5R	Y5V	X7S	X6S	X5R	Y5V	Y5V	
min	1.0µF	1.0µF	1.0µF	1.0µF	1.0µF	1.0µF	1.0µF	1.0µF	1.0µF	1.0µF	1.0µF	1.0µF	1.0µF	1.0µF	1.0µF	1.0µF	1.0µF	1.0µF	1.0µF	1.0µF	1.0µF	1.0µF	1.0µF
4V	1.0µF				10µF			47µF			100µF	100µF			100µF	220µF					220µF		
6.3V	1.0µF	2.2µF	2.2µF	10µF	10µF		22µF	47µF	22µF		47µF	100µF		47µF	47µF	47µF		100µF	100µF	220µF	100µF	100µF	100µF
10V		1.0µF	2.2µF	4.7µF	4.7µF		10µF	22µF	22µF		22µF	47µF			22µF	47µF	10µF		100µF	100µF	47µF		
16V		1.0µF		2.2µF	2.2µF	4.7µF	10µF	10µF	10µF	10µF	22µF	22µF		22µF	22µF	47µF	10µF		47µF	100µF	22µF	47µF	
25V				1.0µF	1.0µF	2.2µF	2.2µF	10µF		10µF	4.7µF	22µF			10µF	22µF			22µF	47µF	10µF		10µF
35V																					4.7µF		10µF
50V								2.2µF				10µF				10µF	1.0µF				10µF	4.7µF	10µF
100V										1.0µF									4.7µF				

DIMENSIONS IN MILLIMETERS

	0201	0402	0603	0805	1206	1210	1812
Length (L)	0.60 ± 0.05 (0.09 C>1.0µF)	1.00 ± 0.20	1.60 ± 0.15	2.00 ± 0.20	3.20 ± 0.20	3.20 ± 0.30	4.50 ± 0.40
Width (W)	0.30 ± 0.05 (0.09 C>1.0µF)	1.00 ± 0.20	0.80 ± 0.202	1.25 ± 0.20	1.60 ± 0.20	2.50 ± 0.30	3.20 ± 0.30
Thickness max (T)		0.33	0.70	0.95	1.45	1.90	2.80
Termination (P)	Min	0.10	0.15	0.25	0.30	0.40	0.40
	Max	0.20	0.30	0.55	0.70	0.80	1.10

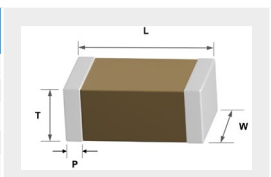

ORDERING INFORMATION

0805	T	103	K	P	X	B	
SIZE	DIELECTRIC	CAPACITANCE	TOLERANCE	VOLTAGE	TERMINATION	PACKAGING	SPECIAL PARAMETERS
0201 0402 0603 0805 1206 1210 1808 1812	T = X7S S = X5R R = X6S V = Y5V	Expressed in picofarads (pF). The first two digits are significant, the third digit gives the number of noughts. Example : 102 = 1 000pF	K = ±10 % (X7S, X5R, X6S) M = ±20 % (X7S, X5R, X6S) Z = -20%+80% (Y5V)	Y = 4V R = 6.3V Q = 10V J = 16V X = 25V Z = 35V A = 50V B = 100V	X = Nickel Tin	B = Taping Reel V = Bulk T = Tray Package	- Dxx = Reliability spec

This document is subject to change without notice.

High Capacitance capacitors

X7S X6S X5R Y5V Series



SRT
MICROCÉRAMIQUE
MLCC CAPACITORS

DF TABLE : X7S/X6S/X5R

Rated	D.F.≤	Exception of D.F.≤	
100V	≤10%		
50V	≤2.5%	≤3.5%	1206<2.2μF, 1210≥2.2μF, 1812≥4.7μF
		≤5%	0201, 1210≥4.7μF
		≤10%	0402, 0603, 0805, 1206≥2.2μF, 1210≥10μF
35V	≤10%		
25V	≤3.5%	≤5%	0805, 1210≥10μF
		≤10%	0201, 0603, 0805≥2.2μF, 1206≥2.2μF, 1210≥22μF
		≤12.5%	0402
16V	≤3.5%	≤5%	0805<2.2μF, 1206≥2.2μF, 1210≥4.7μF
		≤10%	0201, 0402, 0603, 0805≥2.2μF, 1206≥4.7μF, 1210≥22μF
		≤15%	0603<10μF, 0805≥2.2μF, 1206≥2.2μF, 1210≥22μF
10V	≤5%	≤10%	0201, 0402, 0603≥10μF
		≤15%	
		≤20%	0201, 0402<2.2μF, 0603≥10μF, 0805≥4.7μF, 1206≥4.7μF, 1210≥100μF
6.3V	≤10%		
4V	≤15%		

DF TABLE : Y5V

Rated	D.F.≤	Exception of D.F.≤	
50V	≤5%	≤7%	0603, 0805, 1206≥4.7μF
		≤12.5%	1210≥6.8μF
35V	≤7%		
25V	≤5%	≤7%	0805, 1206, 1210≥4.7μF
		≤9%	0402, 0603, 1206≥4.7μF, 1210≥22μF
16V (C<1.0μF)	≤7%	≤9%	0603
		≤12.5%	0402
16V (C≥1.0μF)	≤9%	≤12.5%	0603≥2.2μF, 0805≥3.3μF, 1206≥10μF, 1210≥22μF,
	≤12.5%	≤20%	1812≥4.7μF
10V	≤12.5%		0402
6.3V	≤20%		

THICKNESS CODE :

Code	Thickness (mm)
C	0.30±0.04
E	0.50±0.05
G	0.50±0.20
J	0.80±0.07
K	0.80±0.10
M	0.95±0.10
O	1.15±0.15
P	1.25±0.10
Q	1.25±0.20
T	1.60±0.20
U	1.70±0.20
W	2.00±0.20
X	2.25±0.25
Y	2.50±0.30

This document is subject to change without notice.

High Capacitance capacitors

X7S X6S X5R Y5V Series



SRT
MICROCÉRAMIQUE
MLCC CAPACITORS

X7S

SIZE	0402		0603		0805		1206		1210	
	CAP	6.3V	16V	25V	25V	6.3V	16V	6.3V		
105	1.0 µF									
155	1.5 µF									
225	2.2 µF	G°	K°	K°						
335	3.3 µF									
475	4.7 µF				Q°					
685	6.8 µF									
106	10 µF									
226	22 µF						U°			
476	47 µF						U°			
107	100 µF								Y°	
227	220 µF									

* : tolerance M only, ° : RC≥10⁴ MOhm or 100 Ω/F whichever is less, °° : RC≥50 Ω/F

X6S

SIZE	0201		0402		0603		0805		1206				1210						
	CAP	4V	6.3V	6.3V	10V	16V	4V	6.3V	10V	16V	4V	6.3V	10V	16V	25V	6.3V	10V	25V	
105	1.0 µF	C°	C°	E°	G°	G°													
155	1.5 µF																		
225	2.2 µF			G°	G°		K°	K°	K°					Q°					
335	3.3 µF																		
475	4.7 µF						K°	K°											
685	6.8 µF																		
106	10 µF						K°	K°							Q°	Q°	Q°		U°
226	22 µF						K°	K°							Q°	Q°	Q°		U°
476	47 µF														Q°	Q°			U°
107	100 µF														U°				U°
227	220 µF														U°				U°

* : tolerance M only, ° : RC≥10⁴ MOhm or 100 Ω/F whichever is less, °° : RC≥50 Ω/F

X5R

SIZE	0201		0402		0603		0805		1206				1210										
	CAP	6.3V	10V	16V	4V	6.3V	10V	16V	25V	50V	6.3V	10V	16V	25V	50V	4V	6.3V	10V	16V	25V	35V	50V	
105	1.0 µF	C°	C°	C°		G°	G°	E°	E°		K°	K°	K°	K°									
155	1.5 µF										K°	K°											
225	2.2 µF	C°				T°	E°	G°			K°	K°	K°	K°									
335	3.3 µF										K°	K°											
475	4.7 µF					G°	G°				K°	K°	K°	K°									
685	6.8 µF																						
106	10 µF					G°	G°	G°			K°	K°	K°	K°	K°								
226	22 µF					G°					K°	K°	K°	K°									
476	47 µF										K°	K°											
107	100 µF																						
227	220 µF																						

* : tolerance M only, ° : RC≥10⁴ MOhm or 100 Ω/F whichever is less, °° : RC≥50 Ω/F

Y5V

SIZE	0603		0805		1206		1210		1812									
	CAP	6.3V	10V	16V	25V	50V	10V	16V	25V	35V	50V	10V	16V	25V	50V	100V		
105	1.0 µF	J°	K°		K	K	P	P	M	M	M		M	P	P	P	P	P
155	1.5 µF	J°			P	P			M	M	M		M	P	P	P	P	P
225	2.2 µF	J°	J°		P°	P°			M	M	M		M	P	P	P	P	P
335	3.3 µF				P°	P°			O	O	O		M	P	P	P	P	P
475	4.7 µF				P°	P°			O°	O°	O°	O°	M	P	P	P	P	P
685	6.8 µF				Q°				O°	O°			M	P	P	P	P	P
106	10 µF				Q°	Q°			O°	O°			M	P	P	P	P	P
226	22 µF								U°				P	P	T°	W°		
476	47 µF								W	W			W	W				
107	100 µF								W°	W°			Y					
227	220 µF								Y°									

* : tolerance M only, ° : RC≥10⁴ MOhm or 100 Ω/F whichever is less, °° : RC≥50 Ω/F

This document is subject to change without notice.

Low Inductance Capacitors Class II

6.3V -50V



SRT
MICROCÉRAMIQUE
MLCC CAPACITORS

APPLICATIONS

- Typical uses : high speed energy transfer on semiconductor applications

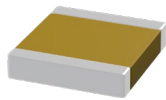

RoHS
compliant

FEATURES

- Inverted geometry reduces the ESL up to 60% to standard MLCC
- Custom voltage, package size, capacitance value on request
- Tested in accordance to CECC 32100 and AEC-Q200
- CECC 30700 et NFC 83-132 compliant

ELECTRICAL PARAMETERS

ELECTRICAL CHARACTERISTICS :
at + 25°C unless otherwise specified

OPERATING TEMPERATURE :
- 55°C, + 125°C

TEMPERATURE COEFFICIENT :
± 15% with 0Vdc applied

DISSIPATION FACTOR :
≤ 2.5% at 1kHz for C ≥ 100pF

INSULATION RESISTANCE (IR) :
25°C/Un 10⁵ MOhm or 1000 Ohm-Farad whichever is less
125°C/Un 10⁴ MOhm or 100 Ohm-Farad whichever is less

DIELECTRIC STRENGTH TEST :
Performed per method 103 of EIA 198-2-E
1.2Un for 5s with 50mA max charging current

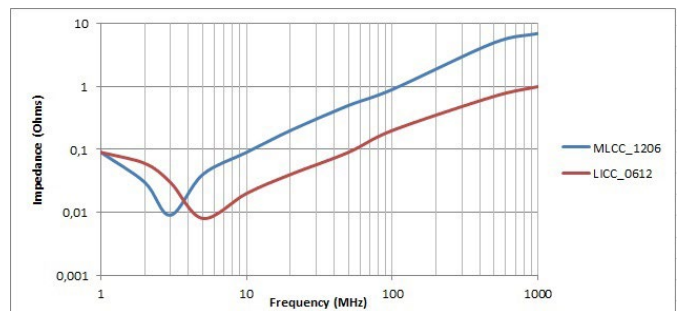
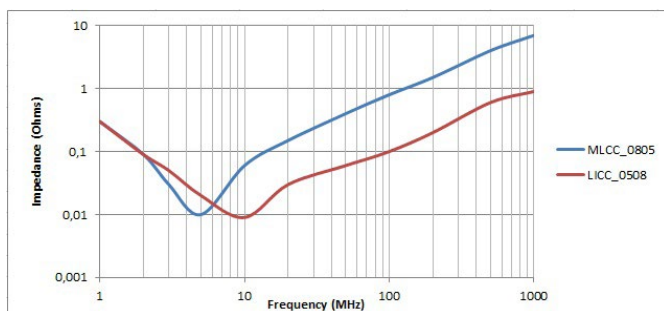

QUICK REFERENCE DATA

	0204	0306	0508	0612
Min	1.0 nF	1.0 nF	1.0 nF	1.0 nF
6.3V	22 nF	220 nF	1.0 μF	1.5 μF
10V		150 nF	1.0 μF	1.5 μF
16V		68 nF	220 nF	330 nF
25V		22 nF	100 nF	220 nF
50V			100 nF	150 nF

Max values italic obtained with BME parts

ORDERING INFORMATION

0805	Y	103	K	C	X	B	XX
SIZE	DIELECTRIC	CAPACITANCE	TOLERANCE	VOLTAGE	TERMINATION	PACKAGING	SPECIAL PARAMETERS
0204 0306 0508 0612	Y = X7R	Expressed in picofarads (pF). The first two digits are significant, the third digit gives the number of noughts. Example : 102 = 1000pF For special values R is used as decimal separator Example 12R7 = 12.7pF 1340R0 = 1340pF	J = ± 5% K = ± 10% M = ± 20%	R = 6.3V Q = 10V J = 16V X = 25V A = 50V	X = Nickel Tin F = Palladium-Silver P = Polymer Tin (Flex) C = Copper Tin (Non magnetic) W = Nickel Gold H = Dipped SnPb I = Electrolytic SnPb Q = Solderable Silver	B = Reel V = Bulk	- BM = BME Dxx = Reliability spec Exx = Sorting spec

For other sizes, voltage, ceramic tolerance contact us

DIMENSIONS IN MILLIMETERS

	0204	0306	0508	0612
Length (L)	0.50 ± 0.1	0.80 ± 0.1	1.30 ± 0.2	1.60 ± 0.2
Width (W)	1.00 ± 0.1	1.60 ± 0.1	2.00 ± 0.2	3.20 ± 0.2
Thickness max (T)	0.60	0.92	2.00	3.00
Termination (P)	Min	0.10	0.25	0.25
	Max	0.40	0.40	0.70

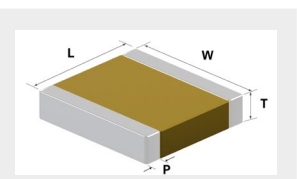

For P termination (Polymer type) add 0.10mm to Length (L) and 0.05 to Width (W)

This document is subject to change without notice.

Low Inductance Capacitors Class II

6.3V -50V



STANDARD SIZE : 0204 to 0612

SIZE		0204				0306				0508					0612				
CODE	CAP	6.3V	6.3V	10V	16V	25V	6.3V	10V	16V	25V	50V	6.3V	10V	16V	25V	50V			
102	1.0 nF																		
122	1.2 nF																		
152	1.5 nF																		
182	1.8 nF																		
222	2.2 nF																		
272	2.7 nF																		
332	3.3 nF																		
392	3.9 nF																		
472	4.7 nF																		
562	5.6 nF																		
682	6.8 nF																		
822	8.2 nF																		
103	10 nF	●																	
123	12 nF	●																	
153	15 nF	●																	
183	18 nF	●																	
223	22 nF	●																	
273	27 nF																		
333	33 nF																		
393	39 nF																		
473	47 nF		●	●	●	●													
563	56 nF		●	●	●	●													
683	68 nF		●	●	●	●													
823	82 nF		●	●	●	●													
104	100 nF		●	●	●	●													
124	120 nF		●	●	●	●	●	●	●	●									
154	150 nF		●	●	●	●	●	●	●	●									
184	180 nF		●	●	●	●	●	●	●	●									
224	220 nF		●	●	●	●	●	●	●	●									
274	270 nF						●	●	●	●									
334	330 nF						●	●	●	●		●	●	●					
394	390 nF						●	●	●	●		●	●	●					
474	470 nF						●	●	●	●		●	●	●					
564	560 nF						●	●	●	●		●	●	●					
684	680 nF						●	●	●	●		●	●	●					
824	820 nF						●	●	●	●		●	●	●					
105	1.0 µF						●					●	●						
125	1.2 µF											●							
155	1.5 µF											●							
185	1.8 µF																		
225	2.2 µF																		
275	2.7 µF																		

● BME parts



TYPICAL CHARACTERISTICS

Capacitance and dissipation factor vs temperature

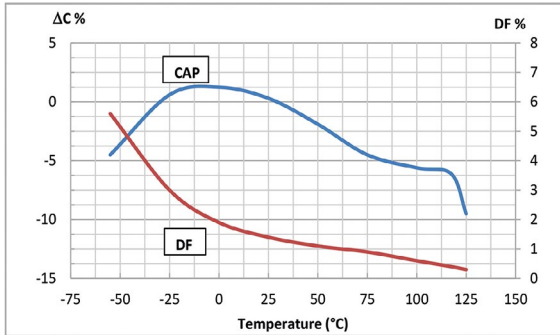

Insulation resistance vs temperature

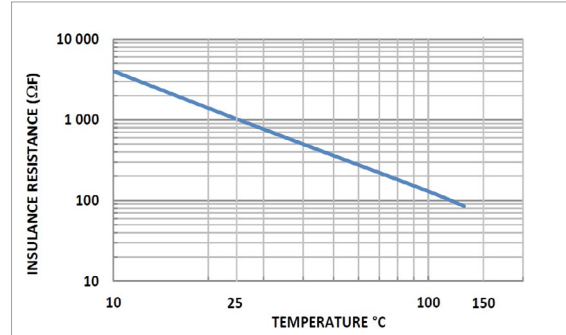

Inductance vs. frequency
0508Y104KXX & 0306Y104KXX

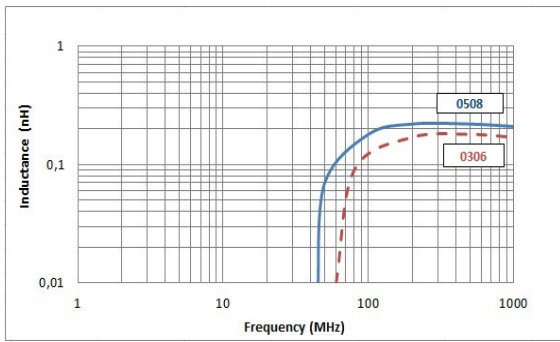

Impedance & ESR vs. frequency
0508Y104KXX & 0306Y104KXX

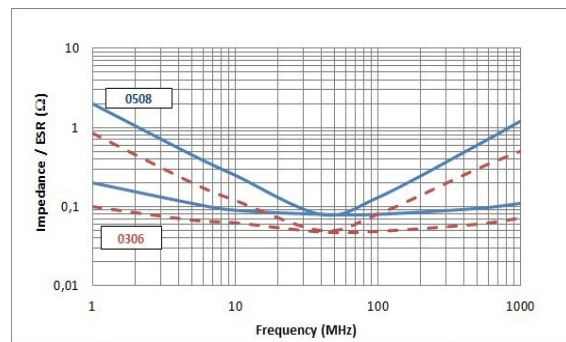

Series resonant frequency 0612

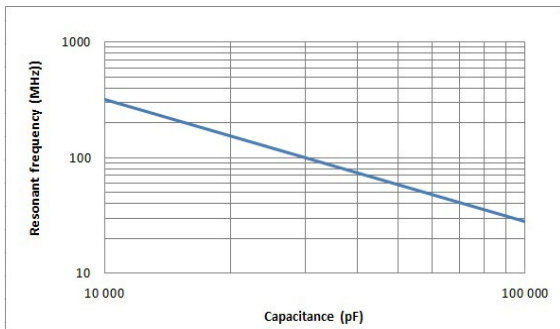

Impedance & ESR vs. frequency 0612Y823KXA

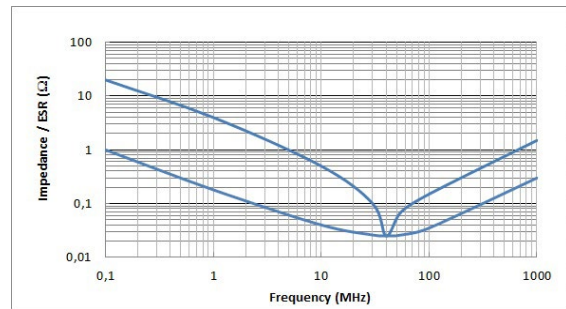

SMD High Voltage Class I

1KV - 15KV



SRT
MICROCÉRAMIQUE
MLCC CAPACITORS

APPLICATIONS

- Typical uses : timing, precision circuitry, filtering

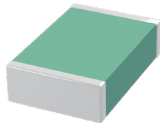

RoHS
compliant

FEATURES

- Ultra stable temperature compensating class I ceramic
- Custom voltage, package size, capacitance value on request
- Tested in accordance to CECC 32100 and AEC-Q200
- CECC 30600 et NFC 83-131 compliant
- Available in stack or radial
- Surface coating can be necessary to prevent surface arcing

ELECTRICAL PARAMETERS

ELECTRICAL CHARACTERISTICS :
at + 25°C unless otherwise specified

OPERATING TEMPERATURE :
- 55°C, + 125°C

TEMPERATURE COEFFICIENT :
± 30ppm with 0Vdc applied

DISSIPATION FACTOR :
≤ 1.10-3 at 1Vrms and 1MHz for values ≤ 1000pF
≤ 1.10-3 at 1Vrms and 1KHz for values > 1000pF

INSULATION RESISTANCE (IR) :
25°C/Un 10⁵ MOhm or 1000 Ohm-Farad whichever is less
125°C/Un 10⁴ MOhm or 100 Ohm-Farad whichever is less

DIELECTRIC STRENGTH TEST :
1.2Un for 5s with 50mA max charging current

QUICK REFERENCE DATA

	0805	1206	1210	1808	1812	1825	2220	2225	2825	3640	4040	5440	5550	6660	8060	80150	15080
Min	0.1 pF	0.4 pF	0.4 pF	1.0 pF	1.0 pF	1.0 pF	1.0 pF	1.0 pF	4.7 pF	10 pF	10 pF	10 pF	10 pF	10 pF	10 pF	22 pF	22 pF
1KV	820 pF	2.7 nF	6.8 nF	6.8 nF	15 nF	33 nF	39 nF	47 nF	56 nF	120 nF	120 nF	180 nF	220 nF	330 nF	390 nF	1.0 μF	1.0 μF
1.5KV	330 pF	1.0 nF	2.7 nF	2.7 nF	8.2 nF	18 nF	18 nF	27 nF	33 nF	68 nF	68 nF	100 nF	120 nF	180 nF	220 nF	560 nF	560 nF
2KV	150 pF	560 pF	1.5 nF	1.2 nF	3.9 nF	10 nF	12 nF	15 nF	18 nF	39 nF	47 nF	56 nF	82 nF	120 nF	120 nF	330 nF	330 nF
3KV		180 pF	470 pF	470 pF	1.2 nF	2.7 nF	2.7 nF	3.9 nF	4.7 nF	10 nF	12 nF	15 nF	18 nF	27 nF	33 nF	82 nF	82 nF
4KV		82 pF	220 pF	220 pF	680 pF	1.8 nF	1.8 nF	2.2 nF	3.3 nF	6.8 nF	8.2 nF	10 nF	12 nF	18 nF	22 nF	56 nF	56 nF
5KV				150 pF	390 pF	1.0 nF	1.2 nF	1.8 nF	2.2 nF	4.7 nF	5.6 nF	6.8 nF	8.2 nF	12 nF	15 nF	39 nF	39 nF
8KV				47 pF	150 pF	330 pF	330 pF	470 pF	560 pF	1.2 nF	1.5 nF	1.8 nF	2.2 nF	3.3 nF	3.9 nF	10 nF	10 nF
10KV				27 pF	82 pF	220 pF	270 pF	330 pF	390 pF	820 pF	1.0 nF	1.2 nF	1.8 nF	2.2 nF	2.7 nF	6.8 nF	6.8 nF
12KV										560 pF	680 pF	820 pF	1.0 nF	1.5 nF	1.8 nF	4.7 nF	4.7 nF
15KV										330 pF	390 pF	560 pF	680 pF	1.0 nF	1.2 nF	2.7 nF	2.7 nF

ORDERING INFORMATION

5440	A	101	K	H	X	B	-
SIZE	DIELECTRIC	CAPACITANCE	TOLERANCE	VOLTAGE	TERMINATION	PACKAGING	SPECIAL PARAMETERS
0805 1206 1210 1808 1812 1825 2220 2225 2825 3033 3640 4040 4055 5440 5550 6660 8060 80150 15080	A = NPO	Expressed in picofarads (pF). The first two digits are significant, the third digit gives the number of noughts. Example : 102 = 1 000pF For special values R is used as decimal separator Example 12R7 = 12.7pF 1340R0 = 1340pF	A = ±0,5% if > 10pF and ±0,05pF si < 10pF B = ± 0,1pF C = ± 0,25pF D = ± 0,5pF E = 0.1% F = ± 1% G = ± 2% J = ± 5% K = ± 10%	G = 1KV O = 1.5KV H = 2KV T = 2.5KV I = 3KV K = 4KV L = 5KV 6 = 6KV 8 = 8KV 10 = 10KV 12 = 12KV 15 = 15KV	X = Nickel Tin F = Palladium-Silver P = Polymer Tin C = Copper Tin W = Nickel Gold Q = Solderable Silver	B = Reel V = Bulk	- BM = BME Dxx = Reliability spec Exx = Sorting spec

For other sizes, voltage, tolerance contact us

DIMENSIONS IN MILLIMETERS

	0805	1206	1210	1808	1812	1825	2220	2225	2825	3640	4040	5440	5550	6660	8060	80150	15080
Length (L)	2.00 ± 0.2	3.20 ± 0.2	3.20 ± 0.2	4.60 ± 0.3	4.60 ± 0.3	4.60 ± 0.4	5.60 ± 0.4	5.60 ± 0.4	7.10 ± 0.4	9.15 ± 0.8	10.20 ± 0.8	13.70 ± 1.0	14.00 ± 1.0	16.80 ± 1.0	20.30 ± 1.0	20.30 ± 1.0	20.30 ± 1.0
Width (W)	1.25 ± 0.2	1.60 ± 0.2	2.50 ± 0.2	2.00 ± 0.2	3.20 ± 0.2	6.35 ± 0.3	5.10 ± 0.4	6.35 ± 0.4	6.35 ± 0.4	10.20 ± 0.8	10.20 ± 0.8	10.20 ± 1.0	12.70 ± 1.0	15.20 ± 1.0	15.20 ± 1.0	38.10 ± 1.0	38.10 ± 1.0
Thickness max(T)	1.40	1.70	2.50	2.20	3.30	3.60	4.00	4.00	4.00	4.00	4.00	4.00	4.00	4.00	4.00	4.00	4.00
Termination (P)	Min	0.25	0.25	0.25	0.25	0.25	0.25	0.25	0.25	0.80	0.80	0.80	0.80	0.80	0.80	0.80	0.80
	Max	0.70	0.70	0.80	0.80	0.80	0.80	1.00	1.00	1.50	1.50	1.50	1.50	1.50	1.50	1.50	1.50

For P termination (Polymer type) add 0.10mm to Length (L) and 0.05 to Width (W)

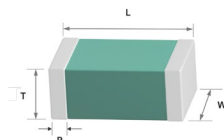

This document is subject to change without notice.



TYPICAL CHARACTERISTICS

NPO Temperature coefficient of capacitance

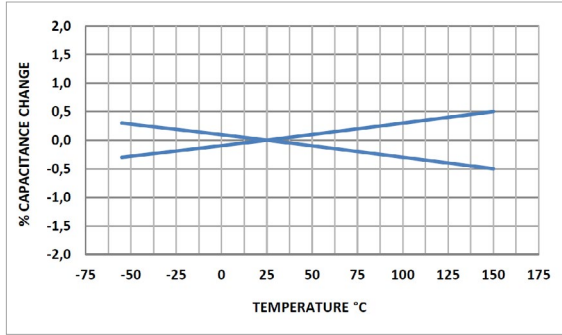

NPO Insulation resistance vs. temperature

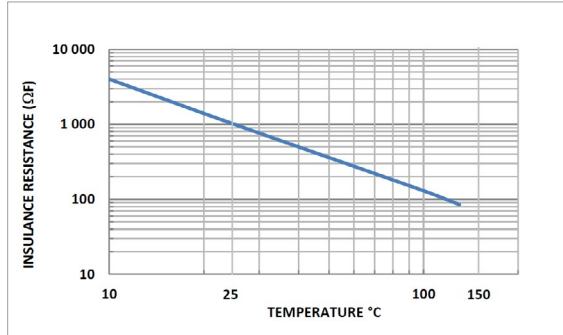

NPO Aging rate

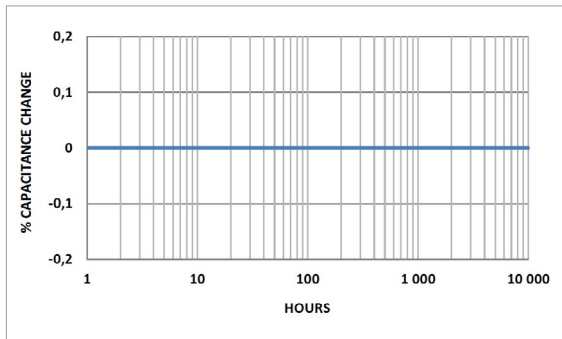

NPO Voltage coefficient of capacitance

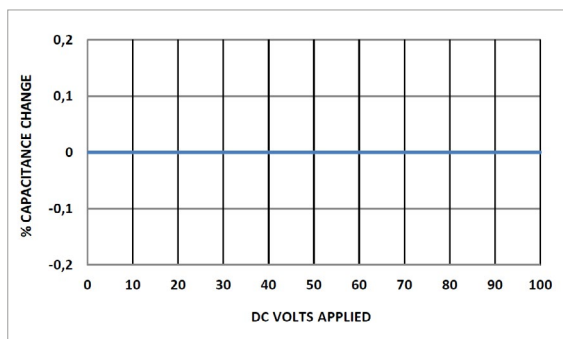

NPO Change of Capacitance with Frequency

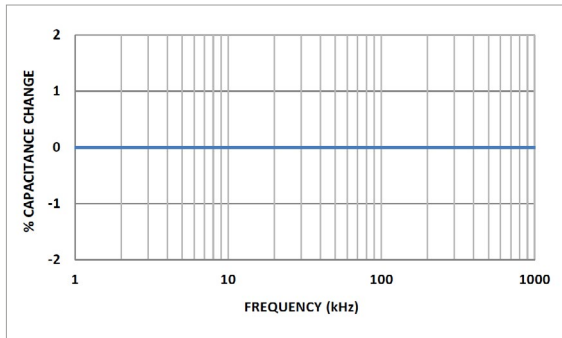

NPO Dissipation factor vs. frequency

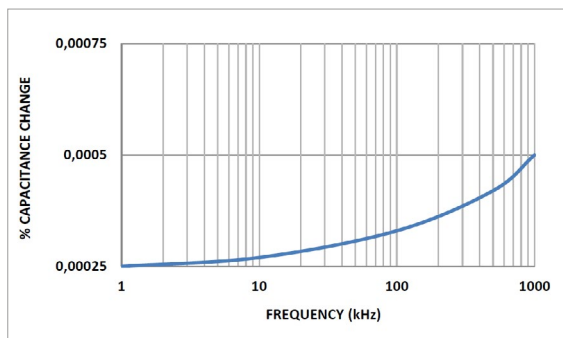

SMD High Voltage N2T

1KV - 15KV



SRT
MICROCÉRAMIQUE
MLCC CAPACITORS

APPLICATIONS

- Typical uses : timing, filtering, pulse discharge

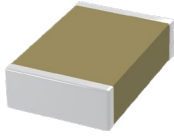

RoHS
compliant

FEATURES

- Class 1,5
- Close to Class 1 stability, high power
- No piezoelectric effect, high current pulse discharge
- Custom voltage, package size, capacitance value on request
- Available in stack or radial
- Surface coating can be necessary to prevent surface arcing

ELECTRICAL PARAMETERS

ELECTRICAL CHARACTERISTICS :
at + 25°C unless otherwise specified

OPERATING TEMPERATURE :
- 55°C, + 125°C

TEMPERATURE COEFFICIENT :
-2200 ± 350 ppm/C° with 0Vdc applied

DISSIPATION FACTOR :
≤ 1.10⁻³ at 1Vrms and 1MHz for values ≤ 1000pF
≤ 1.10⁻³ at 1Vrms and 1KHz for values > 1000pF

INSULATION RESISTANCE (IR) :
25°C/Un 10⁵ MOhm or 1000 Ohm-Farad whichever is less
125°C/Un 10⁴ MOhm or 100 Ohm-Farad whichever is less

DIELECTRIC STRENGTH TEST :
1.2Un for 5s with 50mA max charging current

QUICK REFERENCE DATA

	0805	1206	1210	1808	1812	1825	2220	2225	2825	3640	4040	5440	5550	6660	8060	80150	15080
Min	1.0 pF	4.7 pF	4.7 pF	4.7 pF	4.7 pF	10 pF	10 pF	10 pF	10 pF	47 pF	47 pF	47 pF	47 pF	47 pF	47 pF	68 pF	68 pF
1KV	2.2 nF	8.2 nF	22 nF	18 nF	47 nF	100 nF	120 nF	150 nF	180 nF	390 nF	390 nF	560 nF	680 nF	1.0 µF	1.2 µF	3.3 µF	3.3 µF
1.5KV	820 pF	2.7 nF	6.8 nF	6.8 nF	22 nF	56 nF	56 nF	82 nF	100 nF	180 nF	220 nF	270 nF	390 nF	560 nF	680 nF	1.8 µF	1.8 µF
2KV	390 pF	1.2 nF	3.3 nF	3.3 nF	8.2 nF	18 nF	22 nF	33 nF	39 nF	82 nF	82 nF	120 nF	150 nF	220 nF	270 nF	680 nF	680 nF
3KV		470 pF	1.2 nF	1.2 nF	3.3 nF	10 nF	10 nF	12 nF	18 nF	39 nF	39 nF	56 nF	68 nF	100 nF	120 nF	330 nF	330 nF
4KV		220 pF	680 pF	680 pF	1.8 nF	4.7 nF	4.7 nF	6.8 nF	8.2 nF	18 nF	18 nF	27 nF	33 nF	47 nF	56 nF	150 nF	150 nF
5KV				390 pF	1.2 nF	2.7 nF	3.3 nF	4.7 nF	5.6 nF	12 nF	12 nF	18 nF	22 nF	33 nF	39 nF	100 nF	100 nF
8KV				120 pF	390 pF	1.0 nF	1.2 nF	1.5 nF	2.2 nF	4.7 nF	4.7 nF	6.8 nF	8.2 nF	12 nF	15 nF	33 nF	33 nF
10KV				56 pF	220 pF	560 pF	680 pF	820 pF	1.2 nF	2.7 nF	2.7 nF	3.9 nF	4.7 nF	6.8 nF	8.2 nF	22 nF	22 nF
12KV										1.8 nF	1.8 nF	2.7 nF	3.3 nF	4.7 nF	5.6 nF	15 nF	15 nF
15KV										1.0 nF	1.2 nF	1.5 nF	1.8 nF	2.7 nF	3.3 nF	8.2 nF	8.2 nF

ORDERING INFORMATION

5440	P	101	J	T	X	B	-
SIZE	DIELECTRIC	CAPACITANCE	TOLERANCE	VOLTAGE	TERMINATION	PACKAGING	SPECIAL PARAMETERS
0805 1206 1210 1808 1812 1825 2220 2225 2825 3640 4040 4055 5440 5550 6660 8060 80150 15080	P = N2T	Expressed in picofarads (pF). The first two digits are significant, the third digit gives the number of noughts. Example : 102 = 1 000pF For special values R is used as decimal separator Example 12R7 = 12.7pF 1340R0 = 1340pF	A = ±0.05pF if < 10pF and 0.05% if > 10pF B = ± 0.1pF C = ± 0.25pF D = ± 0.5pF F = ± 1% G = ± 2% J = ± 5%	G = 1KV O = 1.5KV H = 2KV I = 3KV T = 2.5KV K = 4KV L = 5KV 6 = 6KV 8 = 8KV 10 = 10KV 12 = 12KV 15 = 15KV	X = Nickel Tin F = Palladium-Silver P = Polymer Tin C = Copper Tin W = Nickel Gold Q = Solderable Silver	B = Reel V = Bulk	- Dxx = Reliability spec Exx = Sorting spec

For other sizes, voltage, tolerance contact us

DIMENSIONS IN MILLIMETERS

	0805	1206	1210	1808	1812	1825	2220	2225	2825	3640	4040	5440	5550	6660	8060	80150	15080
Length (L)	2.00 ± 0.2	3.20 ± 0.2	3.20 ± 0.2	4.60 ± 0.3	4.60 ± 0.3	4.60 ± 0.4	5.60 ± 0.4	5.60 ± 0.4	7.10 ± 0.4	9.15 ± 0.8	10.20 ± 0.8	13.70 ± 1.0	14.00 ± 1.0	16.80 ± 1.0	20.30 ± 1.0	20.30 ± 1.0	38.10 ± 1.0
Width (W)	1.25 ± 0.2	1.60 ± 0.2	2.50 ± 0.2	2.00 ± 0.2	3.20 ± 0.2	6.35 ± 0.3	5.10 ± 0.4	6.35 ± 0.4	6.35 ± 0.4	10.20 ± 0.8	10.20 ± 0.8	10.20 ± 1.0	12.70 ± 1.0	15.20 ± 1.0	15.20 ± 1.0	38.10 ± 1.0	20.30 ± 1.0
Thickness max(T)	1.40	1.70	2.50	2.20	3.30	3.60	4.00	4.00	4.00	4.00	4.00	4.00	4.00	4.00	4.00	4.00	4.00
Termination (P)	Min Max	0.25 0.70	0.25 0.70	0.25 0.80	0.25 0.80	0.25 0.80	0.25 0.80	0.25 1.00	0.25 1.00	0.80 1.50	0.80 1.50	0.80 1.50	0.80 1.50	0.80 1.50	0.80 1.50	0.80 1.50	0.80 1.50

For P termination (Polymer type) add 0.10mm to Length (L) and 0.05 to Width (W)

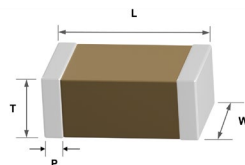

This document is subject to change without notice.

SMD High Voltage N2T

1KV - 15KV



SRT
MICROCÉRAMIQUE
MLCC CAPACITORS

STANDARD SIZE : 0805 to 3640

SIZE	0805		1206		1210		1808		1812		1825		2220		2225		3640				SIZE					
	CODE	CAP	1KV	2KV	1KV	2KV	3KV	4KV	1KV	1.5KV	2KV	3KV	4KV	5KV	8KV	1KV	1.5KV	2KV	3KV	4KV	5KV	8KV	10KV	12KV	CAP	CODE
1R0	1.0 pF																								1.0 pF	1R0
1R2	1.2 pF																								1.2 pF	1R2
1R5	1.5 pF																								1.5 pF	1R5
1R8	1.8 pF																								1.8 pF	1R8
2R2	2.2 pF																								2.2 pF	2R2
2R7	2.7 pF																								2.7 pF	2R7
3R3	3.3 pF																								3.3 pF	3R3
3R9	3.9 pF																								3.9 pF	3R9
4R7	4.7 pF																								4.7 pF	4R7
5R6	5.6 pF																								5.6 pF	5R6
6R8	6.8 pF																								6.8 pF	6R8
8R2	8.2 pF																								8.2 pF	8R2
100	10 pF																								10 pF	100
120	12 pF																								12 pF	120
150	15 pF																								15 pF	150
180	18 pF																								18 pF	180
220	22 pF																								22 pF	220
270	27 pF																								27 pF	270
330	33 pF																								33 pF	330
390	39 pF																								39 pF	390
470	47 pF																								47 pF	470
560	56 pF																								56 pF	560
680	68 pF																								68 pF	680
820	82 pF																								82 pF	820
101	100 pF																								100 pF	101
121	120 pF																								120 pF	121
151	150 pF																								150 pF	151
181	180 pF																								180 pF	181
221	220 pF																								220 pF	221
271	270 pF																								270 pF	271
331	330 pF																								330 pF	331
391	390 pF																								390 pF	391
471	470 pF																								470 pF	471
561	560 pF																								560 pF	561
681	680 pF																								680 pF	681
821	820 pF																								820 pF	821
102	1.0 nF																								1.0 nF	102
122	1.2 nF																								1.2 nF	122
152	1.5 nF																								1.5 nF	152
182	1.8 nF																								1.8 nF	182
222	2.2 nF																								2.2 nF	222
272	2.7 nF																								2.7 nF	272
332	3.3 nF																								3.3 nF	332
392	3.9 nF																								3.9 nF	392
472	4.7 nF																								4.7 nF	472
562	5.6 nF																								5.6 nF	562
682	6.8 nF																								6.8 nF	682
822	8.2 nF																								8.2 nF	822
103	10 nF																								10 nF	103
123	12 nF																								12 nF	123
153	15 nF																								15 nF	153
183	18 nF																								18 nF	183
223	22 nF																								22 nF	223
273	27 nF																								27 nF	273
333	33 nF																								33 nF	333
393	39 nF																								39 nF	393
473	47 nF																								47 nF	473
563	56 nF																								56 nF	563
683	68 nF																								68 nF	683
823	82 nF																								82 nF	823
104	100 nF																								100 nF	104
124	120 nF																								120 nF	124
154	150 nF																								150 nF	154
184	180 nF																								180 nF	184
224	220 nF																								220 nF	224
274	270 nF																								270 nF	274
334	330 nF																								330 nF	334
394	390 nF																								390 nF	394
474	470 nF																								470 nF	474
564	560 nF																								560 nF	564
684	680 nF																								680 nF	684

This document is subject to change without notice.



TYPICAL CHARACTERISTICS

N2T Capacitance vs. temperature

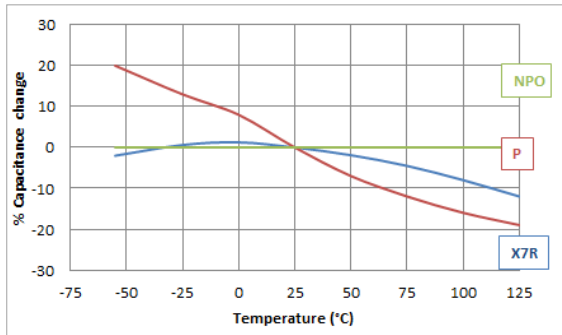

N2T Dissipation factor vs. temperature

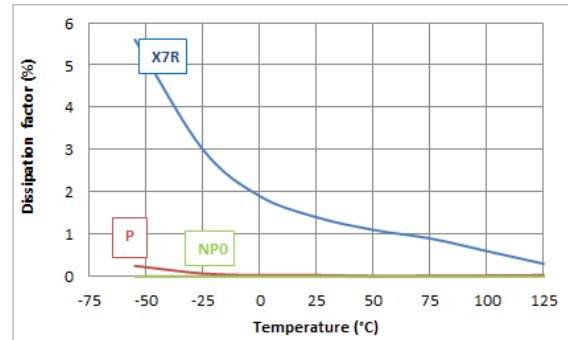

N2T Capacitance vs. voltage

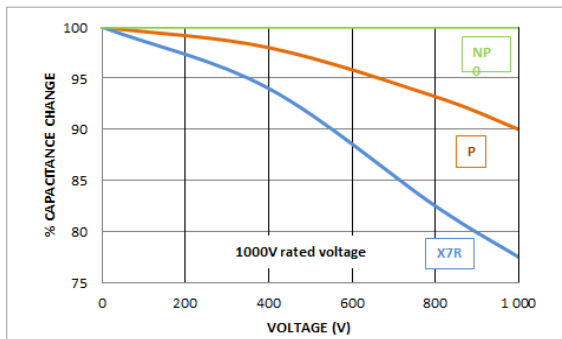

SMD High Voltage Class II

1KV - 15KV



SRT
MICROCÉRAMIQUE
MLCC CAPACITORS

APPLICATIONS

- Typical uses : passing, coupling, filtering, blocking

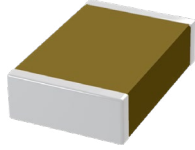

RoHS
compliant

FEATURES

- Temperature stable class II ceramic
- Custom voltage, package size, capacitance value on request
- Tested in accordance to CECC 32100 and AEC-Q200
- CECC 30700 et NFC 83-132 compliant
- Available in stack or radial
- Surface coating can be necessary to prevent surface arcing

ELECTRICAL PARAMETERS

ELECTRICAL CHARACTERISTICS :
at + 25°C unless otherwise specified

OPERATING TEMPERATURE :
- 55°C, + 125°C

TEMPERATURE COEFFICIENT :
± 15% with 0Vdc applied

DISSIPATION FACTOR :
≤ 2.5% at 1kHz for C ≥ 100pF

INSULATION RESISTANCE (IR) :
25°C/Un 10⁵ MOhm or 1000 Ohm-Farad whichever is less
125°C/Un 10⁴ MOhm or 100 Ohm-Farad whichever is less

DIELECTRIC STRENGTH TEST :
1.2Un for 5s with 50mA max charging current

QUICK REFERENCE DATA

	0805	1206	1210	1808	1812	1825	2220	2225	2825	3640	4040	5440	5550	6660	8060	80150	15080
Min	6.8 pF	10 pF	10 pF	10 pF	10 pF	33 pF	33 pF	33 pF	33 pF	100 pF	100 pF	100 pF	100 pF	100 pF	100 pF	180 pF	180 pF
1KV	5.6 nF	15 nF	47 nF	39 nF	120 nF	330 nF	330 nF	470 nF	560 nF	1.2 µF	1.2 µF	1.8 µF	2.2 µF	3.3 µF	3.9 µF	10 µF	10 µF
1.5KV	1.8 nF	5.6 nF	18 nF	15 nF	56 nF	120 nF	150 nF	180 nF	220 nF	470 nF	560 nF	680 nF	1.0 µF	1.2 µF	1.5 µF	3.9 µF	3.9 µF
2KV	820 pF	2.7 nF	8.2 nF	8.2 nF	22 nF	56 nF	68 nF	82 nF	120 nF	270 nF	270 nF	390 nF	470 nF	680 nF	820 nF	2.2 µF	2.2 µF
3KV		1.0 nF	2.7 nF	3.3 nF	8.2 nF	22 nF	27 nF	39 nF	47 nF	100 nF	120 nF	150 nF	180 nF	270 nF	330 nF	820 nF	820 nF
4KV		470 pF	1.5 nF	1.5 nF	4.7 nF	12 nF	15 nF	18 nF	27 nF	56 nF	56 nF	82 nF	100 nF	150 nF	180 nF	470 nF	470 nF
5KV				820 pF	2.7 nF	6.8 nF	8.2 nF	12 nF	15 nF	33 nF	33 nF	47 nF	56 nF	82 nF	100 nF	270 nF	270 nF
8KV				270 pF	1.0 nF	2.7 nF	2.7 nF	3.3 nF	4.7 nF	10 nF	12 nF	15 nF	18 nF	27 nF	33 nF	82 nF	82 nF
10KV							1.5 nF	1.8 nF	2.7 nF	5.6 nF	6.8 nF	8.2 nF	10 nF	15 nF	18 nF	47 nF	47 nF
12KV										3.9 nF	4.7 nF	5.6 nF	6.8 nF	10 nF	12 nF	33 nF	33 nF
15KV											2.7 nF	3.3 nF	3.9 nF	5.6 nF	6.8 nF	18 nF	18 nF

ORDERING INFORMATION

5440	Y	103	K	H	X	B	-
SIZE	DIELECTRIC	CAPACITANCE	TOLERANCE	VOLTAGE	TERMINATION	PACKAGING	SPECIAL PARAMETERS
0805 1206 1210 1808 1812 1825 2220 2225 2825 3033 3640 4040 4055 40100 5550 6660 8060 80150	Y = X7R	Expressed in picofarads (pF). The first two digits are significant, the third digit gives the number of noughts. Example : 102 = 1 000pF For special values R is used as decimal separator Example 12R7 = 12.7pF 1340R0 = 1340pF	J = ± 5% K = ± 10% M = ± 20%	G = 1KV O = 1.5KV H = 2KV T = 2.5KV I = 3KV K = 4KV L = 5KV 6 = 6KV 8 = 8KV 10 = 10KV 12 = 12KV 15 = 15KV	X = Nickel Tin F = Palladium-Silver P = Polymer Tin C = Copper Tin W = Nickel Gold	B = Reel V = Bulk	- BM = BME Dxx = Reliability spec Exx = Sorting spec

For other sizes, voltage, tolerance contact us.

DIMENSIONS IN MILLIMETERS

	0805	1206	1210	1808	1812	1825	2220	2225	2825	3640	4040	5440	5550	6660	8060	80150	15080
Length (L)	2.00 ± 0.2	3.20 ± 0.2	3.20 ± 0.2	4.60 ± 0.3	4.60 ± 0.3	4.60 ± 0.4	5.60 ± 0.4	5.60 ± 0.4	7.10 ± 0.4	9.15 ± 0.8	10.20 ± 0.8	13.70 ± 1.0	14.00 ± 1.0	16.80 ± 1.0	20.30 ± 1.0	20.30 ± 1.0	38.10 ± 1.0
Width (W)	1.25 ± 0.2	1.60 ± 0.2	2.50 ± 0.2	2.00 ± 0.2	3.20 ± 0.2	6.35 ± 0.3	5.10 ± 0.4	6.35 ± 0.4	6.35 ± 0.4	10.20 ± 0.8	10.20 ± 0.8	10.20 ± 1.0	12.70 ± 1.0	15.20 ± 1.0	15.20 ± 1.0	38.10 ± 1.0	20.30 ± 1.0
Thickness max(T)	1.40	1.70	2.50	2.20	3.30	3.60	4.30	4.30	4.30	4.30	4.30	4.30	4.30	4.30	4.30	4.30	4.30
Termination (P)	Min Max	0.25 0.70	0.25 0.70	0.25 0.80	0.25 0.80	0.25 0.80	0.25 0.80	0.25 1.00	0.25 1.00	0.25 1.50	0.80 1.50	0.80 1.50	0.80 1.50	0.80 1.50	0.80 1.50	0.80 1.50	0.80 1.50

For P termination (Polymer type) add 0.10mm to Length (L) and 0.05 to Width (W)

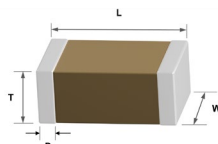

This document is subject to change without notice.

SMD High Voltage Class II

1KV - 15KV



SRT
MICROCÉRAMIQUE
MLCC CAPACITORS

STANDARD SIZE : 0805 to 3640

SIZE		0805		1206		1210		1808		1812		1825		2220		2225		3640					SIZE						
CODE	CAP	1KV	2KV	1.5KV	2KV	3KV	1.5KV	2KV	3KV	4KV	5KV	1.5KV	2KV	3KV	4KV	5KV	8KV	1KV	1.5KV	2KV	3KV	4KV	5KV	8KV	10KV	12KV	CAP	CODE	
220	22 pF																											22 pF	220
270	27 pF																											27 pF	270
330	33 pF																											33 pF	330
390	39 pF																											39 pF	390
470	47 pF																											47 pF	470
560	56 pF																											56 pF	560
680	68 pF																											68 pF	680
820	82 pF																											82 pF	820
101	100 pF																											100 pF	101
121	120 pF																											120 pF	121
151	150 pF																											150 pF	151
181	180 pF																											180 pF	181
221	220 pF																											220 pF	221
271	270 pF																											270 pF	271
331	330 pF																											330 pF	331
391	390 pF																											390 pF	391
471	470 pF																											470 pF	471
561	560 pF																											560 pF	561
681	680 pF																											680 pF	681
821	820 pF																											820 pF	821
102	1.0 nF																											1.0 nF	102
122	1.2 nF																											1.2 nF	122
152	1.5 nF																											1.5 nF	152
182	1.8 nF																											1.8 nF	182
222	2.2 nF																											2.2 nF	222
272	2.7 nF																											2.7 nF	272
332	3.3 nF																											3.3 nF	332
392	3.9 nF																											3.9 nF	392
472	4.7 nF																											4.7 nF	472
562	5.6 nF																											5.6 nF	562
682	6.8 nF																											6.8 nF	682
822	8.2 nF																											8.2 nF	822
103	10 nF																											10 nF	103
123	12 nF																											12 nF	123
153	15 nF																											15 nF	153
183	18 nF																											18 nF	183
223	22 nF																											22 nF	223
273	27 nF																											27 nF	273
333	33 nF																											33 nF	333
393	39 nF																											39 nF	393
473	47 nF																											47 nF	473
563	56 nF																											56 nF	563
683	68 nF																											68 nF	683
823	82 nF																											82 nF	823
104	100 nF																											100 nF	104
124	120 nF																											120 nF	124
154	150 nF																											150 nF	154
184	180 nF																											180 nF	184
224	220 nF																											220 nF	224
274	270 nF																											270 nF	274
334	330 nF																											330 nF	334
394	390 nF																											390 nF	394
474	470 nF																											470 nF	474
564	560 nF																											560 nF	564
684	680 nF																											680 nF	684
824	820 nF																											820 nF	824
105	1.0 μF																											1.0 μF	105
125	1.2 μF																											1.2 μF	125
155	1.5 μF																											1.5 μF	155
185	1.8 μF																											1.8 μF	185
225	2.2 μF																											2.2 μF	225
275	2.7 μF																											2.7 μF	275
335	3.3 μF																											3.3 μF	335
395	3.9 μF																											3.9 μF	395
475	4.7 μF																											4.7 μF	475
565	5.6 μF																											5.6 μF	565
685	6.8 μF																											6.8 μF	685
825	8.2 μF																											8.2 μF	825
106	10 μF																											10 μF	106
126	12 μF																											12 μF	126
156	15 μF																											15 μF	156

This document is subject to change without notice.



TYPICAL CHARACTERISTICS

X7R Capacitance and factor vs temperature

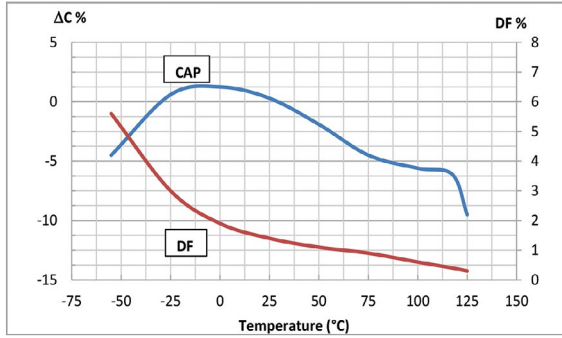

X7R Voltage coefficient of capacitance

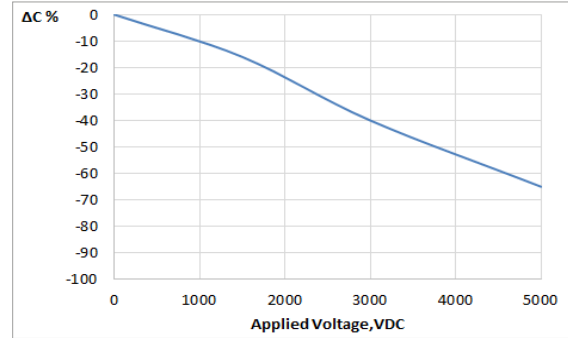

X7R Aging

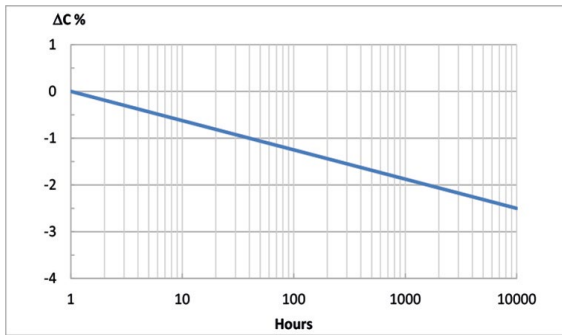

X7R Insulation resistance vs temperature

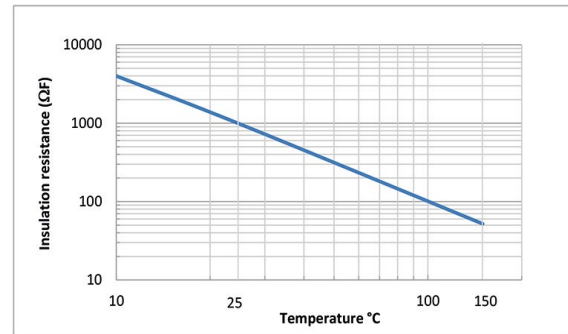



APPLICATIONS

- Magnetic resonance imaging
- Medical test equipment
- Laboratory analyze system
- Audio amplifier
- Particle accelerator



FEATURES

- Non magnetic material : precious metal inner electrode, copper barrier
- All size/voltage available in non magnetic form
- Custom voltage, package size, capacitance value on request
- Tested in accordance to AEC-Q200 methodology
- Magnetic properties tested

ELECTRICAL PARAMETERS

ELECTRICAL CHARACTERISTICS :
at + 25°C unless otherwise specified

OPERATING TEMPERATURE :
- 55°C, + 125°C

TEMPERATURE COEFFICIENT :
NPO : ± 30ppm
N2T : 2200 ± 350 ppm/C°
X7R : ± 15% with 0Vdc applied

AGING RATE :
X7R : 2% per decade

Dissipation Factor :
NPO, N2T : ≤ 1.10⁻³ at 1Vrms and 1MHz for values ≤ 1000pF
 : ≤ 1.10⁻³ at 1Vrms and 1KHz for values > 1000pF
X7R : ≤ 0.025 at 1kHz

INSULATION RESISTANCE (IR) :
25°C/Un 10⁵ MOhm or 1000 Ohm-Farad whichever is less
125°C/Un 10⁴ MOhm or 100 Ohm-Farad whichever is less

DIELECTRIC STRENGTH TEST :
2.5Un U ≤ 200V | U + 250V 200 < U ≤ 500 | 1.5U 500 < U < 1000 | 1.2U U ≥ 1000
for 5s with 50mA max charging current

QUICK REFERENCE DATA

	0402			0504			0603			0805			1206			1210			1808		
	NPO	N2T	X7R	NPO	N2T	X7R	NPO	N2T	X7R	NPO	N2T	X7R	NPO	N2T	X7R	NPO	N2T	X7R	NPO	N2T	X7R
Min	0.1 pF	0.3 pF	2.2 pF	0.1 pF	0.3 pF	2.2 pF	0.1 pF	0.3 pF	2.2 pF	0.1 pF	1.0 pF	6.8 pF	0.4 pF	4.7 pF	10 pF	0.4 pF	4.7 pF	10 pF	1.0 pF	4.7 pF	10 pF
25V	270 pF	1.2 nF	8.2 nF	1.5 nF	5.6 nF	39 nF	1.5 nF	5.6 nF	39 nF	3.9 nF	15 nF	100 nF	10 nF	39 nF	220 nF	15 nF	68 nF	390 nF	22 nF	82 nF	470 nF
50V	270 pF	1.2 nF	8.2 nF	1.5 nF	5.6 nF	39 nF	1.2 nF	5.6 nF	39 nF	3.9 nF	15 nF	100 nF	10 nF	39 nF	220 nF	15 nF	68 nF	390 nF	22 nF	82 nF	470 nF
100V	270 pF	1.2 nF	8.2 nF	1.5 nF	5.6 nF	39 nF	1.2 nF	5.6 nF	39 nF	3.9 nF	15 nF	100 nF	10 nF	39 nF	220 nF	15 nF	68 nF	390 nF	22 nF	82 nF	470 nF
200V	270 pF	1.0 nF	6.8 nF	1.2 nF	5.6 nF	39 nF	1.2 nF	5.6 nF	39 nF	3.9 nF	15 nF	100 nF	10 nF	39 nF	220 nF	15 nF	68 nF	390 nF	22 nF	82 nF	470 nF
500V	180 pF	330 pF	1.2 nF	1.0 nF	1.8 nF	6.8 nF	1.0 nF	1.8 nF	6.8 nF	3.3 nF	6.8 nF	27 nF	8.2 nF	22 nF	82 nF	15 nF	39 nF	180 nF	18 nF	47 nF	220 nF
1000V							220 pF	390 pF	1.2 nF	820 pF	1.8 nF	5.6 nF	2.7 nF	5.6 nF	15 nF	6.8 nF	15 nF	47 nF	6.8 nF	15 nF	39 nF
2000V										150 pF	270 pF	820 pF	560 pF	820 pF	2.7 nF	1.5 nF	2.7 nF	8.2 nF	1.2 nF	2.2 nF	8.2 nF
3000V													180 pF	330 pF	1.0 nF	470 pF	1.0 nF	2.7 nF	470 pF	1.0 nF	3.3 nF

	1825			2220			2225			3033			3640			4040			5440		
	NPO	N2T	X7R	NPO	N2T	X7R	NPO	N2T	X7R	NPO	N2T	X7R	NPO	N2T	X7R	NPO	N2T	X7R	NPO	N2T	X7R
Min	1.0 pF	10 pF	33 pF	1.0 pF	10 pF	33 pF	1.0 pF	10 pF	33 pF	10 pF	47 pF	100 pF	10 pF	47 pF	100 pF	10 pF	47 pF	100 pF	10 pF	47 pF	100 pF
50V	82 nF	270 nF	1.8 μF	82 nF	330 nF	1.8 μF	100 nF	390 nF	2.2 μF	150 nF	680 nF	3.9 μF	220 nF	820 nF	5.6 μF	270 nF	1.0 μF	5.6 μF	330 nF	1.2 μF	8.2 μF
100V	82 nF	270 nF	1.8 μF	82 nF	330 nF	1.8 μF	100 nF	390 nF	2.2 μF	150 nF	680 nF	3.9 μF	220 nF	820 nF	5.6 μF	270 nF	1.0 μF	5.6 μF	330 nF	1.2 μF	8.2 μF
200V	82 nF	270 nF	1.8 μF	82 nF	330 nF	1.8 μF	100 nF	390 nF	2.2 μF	150 nF	680 nF	3.9 μF	220 nF	820 nF	5.6 μF	270 nF	1.0 μF	5.6 μF	330 nF	1.2 μF	8.2 μF
500V	68 nF	180 nF	820 nF	68 nF	180 nF	820 nF	82 nF	220 nF	1.0 μF	150 nF	390 nF	1.8 μF	220 nF	560 nF	2.7 μF	270 nF	680 nF	2.7 μF	330 nF	1.0 μF	3.9 μF
630V	56 nF	150 nF	560 nF	56 nF	150 nF	560 nF	68 nF	180 nF	820 nF	120 nF	330 nF	1.2 μF	180 nF	470 nF	1.8 μF	220 nF	560 nF	2.2 μF	270 nF	680 nF	2.7 μF
1000V	33 nF	82 nF	330 nF	39 nF	100 nF	330 nF	47 nF	120 nF	470 nF	82 nF	220 nF	820 nF	120 nF	330 nF	1.2 μF	120 nF	330 nF	1.2 μF	180 nF	470 nF	1.8 μF
2000V	10 nF	15 nF	56 nF	12 nF	15 nF	68 nF	15 nF	18 nF	82 nF	27 nF	39 nF	180 nF	39 nF	56 nF	270 nF	47 nF	56 nF	270 nF	56 nF	82 nF	390 nF
3000V	2.7 nF	5.6 nF	22 nF	2.7 nF	6.8 nF	27 nF	3.9 nF	8.2 nF	33 nF	6.8 nF	15 nF	56 nF	10 nF	22 nF	82 nF	12 nF	27 nF	100 nF	15 nF	33 nF	120 nF
10KV	220 pF	270 pF		270 pF	470 pF	1.2 nF	330 pF	680 pF	1.8 nF	680 pF	1.2 nF	3.3 nF	1.0 nF	1.8 nF	4.7 nF	1.0 nF	1.8 nF	5.6 nF	1.5 nF	2.7 nF	6.8 nF

ORDERING INFORMATION

0603	A	103	J	B	C	B	-
SIZE	DIELECTRIC	CAPACITANCE	TOLERANCE	VOLTAGE	TERMINATION	PACKAGING	SPECIAL PARAMETERS
0402 0504 0603 0805 1206 1210 1808 1812 1825 2220 2225 2825 3033 3640 4040 5440	A = NPO P = N2T Y = X7R	Expressed in picofarads (pF). The first two digits are significant, the third digit gives the number of noughts. Example : 102 = 1 000pF For special values R is used as decimal separator Example 12R7 = 12.7pF 1340R0 = 1340pF	A = ±0.05pF if < 10pF and 0.05% if > 10pF B = ± 0.1pF C = ± 0.25pF D = ± 0.5pF F = ± 1% G = ± 2% J = ± 5% K = ± 10% M = ± 20%	X = 25V A = 50V U = 63V B = 100V C = 200V P = 250V E = 500V F = 630V G = 1000V H=2000V I=3000V 10=10000V	C = Copper Tin (Non magnetic)	B = Reel V = Bulk	- Dxx = Reliability spec Exx = Sorting spec



APPLICATIONS

- Improved reliability termination
- Whisker free
- Space and medical and oil application
- High Reliability testing, burn-in, screening available



FEATURES

- Choice between :
- Electrolytical SnPb (10% min Pb)
- Dipped SnPb (Sn62 Pb36 Ag2)
- Dipped SAC (Sn96.5 Ag3 Cu0.5) ROHS
- Other size/voltage available on demand
- Other passive/active component dipping on demand

ELECTRICAL PARAMETERS

ELECTRICAL CHARACTERISTICS :
at + 25°C unless otherwise specified

OPERATING TEMPERATURE :
- 55°C, + 125°C

TEMPERATURE COEFFICIENT :

- NPO : ± 30ppm
- N2T : 2200 ± 350 ppm/°C
- X7R : ± 15% with 0Vdc applied

AGING RATE :

- X7R : 2% per decade

Dissipation Factor :

- NPO, N2T : ≤ 1.10⁻³ at 1Vrms and 1MHz for values ≤ 1000pF
: ≤ 1.10⁻³ at 1Vrms and 1KHz for values > 1000pF
- X7R : ≤ 0.025 at 1kHz

INSULATION RESISTANCE (IR) :

- 25°C/Un 10⁵ MOhm or 1000 Ohm-Farad whichever is less
- 125°C/Un 10⁴ MOhm or 100 Ohm-Farad whichever is less

DIELECTRIC STRENGTH TEST :

- 2.5Un U ≤ 200V | U + 250V 200 < U ≤ 500 | 1.5U 500 < U < 1000
for 5s with 50mA max charging current

QUICK REFERENCE DATA

	0402			0603			0805			1206			1210			1812			2220			
	NPO	N2T	X7R	NPO	N2T	X7R	NPO	N2T	X7R	NPO	N2T	X7R	NPO	N2T	X7R	NPO	N2T	X7R	NPO	N2T	X7R	
Min	0.1 pF	0.3 pF	2.2 pF	0.1 pF	0.3 pF	2.2 pF	0.1 pF	1.0 pF	6.8 pF	0.4 pF	4.7 pF	10 pF	0.4 pF	4.7 pF	10 pF	1.0 pF	4.7 pF	10 pF	1.0 pF	10 pF	10 pF	33 pF
10V	2.2 nF	1.2 nF	470 nF	27 nF	5.6 nF	4.7 μF	47 nF	15 nF	10 μF	220 nF	39 nF	22 μF	220 nF	68 nF	47 μF	220 nF	120 nF	22 μF	470 nF	330 nF	47 μF	
25V	2.2 nF	1.2 nF	220 nF	27 nF	5.6 nF	1.0 μF	47 nF	15 nF	4.7 μF	220 nF	39 nF	10 μF	220 nF	68 nF	22 μF	220 nF	120 nF	22 μF	470 nF	330 nF	47 μF	
50V	1.5 nF	1.2 nF	100 nF	10 nF	5.6 nF	1.0 μF	47 nF	15 nF	4.7 μF	220 nF	39 nF	10 μF	150 nF	68 nF	10 μF	220 nF	120 nF	6.8 μF	470 nF	330 nF	22 μF	
63V	1.0 nF	1.2 nF	10 nF	10 nF	5.6 nF	100 nF	33 nF	15 nF	1.0 μF	100 nF	39 nF	2.2 μF	100 nF	68 nF	10 μF	150 nF	120 nF	4.7 μF	330 nF	330 nF	22 μF	
100V	1.0 nF	1.2 nF	10 nF	10 nF	5.6 nF	100 nF	33 nF	15 nF	1.0 μF	100 nF	39 nF	2.2 μF	100 nF	68 nF	4.7 μF	150 nF	120 nF	4.7 μF	330 nF	330 nF	22 μF	
200V	330 pF	1.0 nF	6.8 nF	2.2 nF	5.6 nF	39 nF	10 nF	15 nF	470 nF	22 nF	39 nF	220 nF	47 nF	68 nF	1.0 μF	100 nF	120 nF	1.0 μF	150 nF	330 nF	2.2 μF	
250V	330 pF	1.0 nF	5.6 nF	2.2 nF	5.6 nF	27 nF	10 nF	15 nF	82 nF	22 nF	39 nF	220 nF	47 nF	68 nF	680 nF	100 nF	120 nF	1.0 μF	150 nF	330 nF	2.2 μF	
500V	180 pF	330 pF	1.2 nF	1.0 nF	1.8 nF	6.8 nF	3.3 nF	6.8 nF	33 nF	8.2 nF	22 nF	82 nF	15 nF	39 nF	180 nF	33 nF	82 nF	470 nF	68 nF	180 nF	1.0 μF	
630V				560 pF	1.2 nF	3.9 nF	2.2 nF	4.7 nF	33 nF	6.8 nF	15 nF	56 nF	12 nF	33 nF	120 nF	27 nF	68 nF	270 nF	56 nF	150 nF	1.0 μF	
1000V				220 pF	390 pF	1.2 nF	820 pF	1.8 nF	5.6 nF	2.7 nF	5.6 nF	27 nF	6.8 nF	15 nF	68 nF	15 nF	39 nF	150 nF	39 nF	100 nF	470 nF	

Max values italic obtained with BME parts

ORDERING INFORMATION

0603	A	103	J	B	H	B	-
SIZE	DIELECTRIC	CAPACITANCE	TOLERANCE	VOLTAGE	TERMINATION	PACKAGING	SPECIAL PARAMETERS
0402 0603 0805 1206 1210 1812 2220	A = NPO P = N2T Y = X7R	Expressed in picofarads (pF). The first two digits are significant, the third digit gives the number of noughts. Example : 102 = 1 000pF For special values R is used as decimal separator Example 12R7 = 12.7pF 1340R0 = 1340pF	A = ±0.05pF if < 10pF and 0.05% if > 10pF B = ± 0.1pF C = ± 0.25pF D = ± 0.5pF F = ± 1% G = ± 2% J = ± 5% K = ± 10% M = ± 20%	Q = 10V X = 25V A = 50V U = 63V B = 100V C = 200V P = 250V E = 500V F = 630V G = 1000V	H = Dipped SnPb S = Dipped SAC I = Electrolytic SnPb	B = Reel V = Bulk	- Dxx = Reliability spec Exx = Sorting spec

For other sizes, voltage, ceramic tolerance contact us

SMD High Temperature Class I

10V-2000V 200°C-250°C



SRT
MICROCÉRAMIQUE
MLCC CAPACITORS

APPLICATIONS

- Typical uses : timing, precision circuitry, filtering for High Temperature environnement

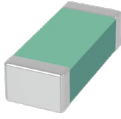

FEATURES

- Ultra stable temperature compensating classe I ceramic up to 250°C
- Robust design for High Temperature durability
- ROHS Tin Termination or Non ROHS SnPb for use up to 200°C (use HMP soldering)
- Gold/Silver-Palladium/Solderable Silver for use up to 250°C (use High-Temperature Epoxy)
- Custom voltage, package size, capacitance value on request
- 168H/125°C Burn-In option for maximum reliability

ELECTRICAL PARAMETERS

ELECTRICAL CHARACTERISTICS :
at + 25°C unless otherwise specified

OPERATING TEMPERATURE :
- 55°C, + 250°C

TEMPERATURE COEFFICIENT :
± 30ppm with 0Vdc applied

DISSIPATION FACTOR :
≤ 1.10-3 at 1Vrms and 1MHz for values ≤ 1000pF
≤ 1.10-3 at 1Vrms and 1KHz for values > 1000pF

INSULATION RESISTANCE (IR) :
25°C/Un 10⁵ MOhm or 1000 Ohm-Farad whichever is less
200°C/Un 10⁴ MOhm or 100 Ohm-Farad whichever is less
250°C/Un 5x10³ MOhm or 50 Ohm-Farad whichever is less

DIELECTRIC STRENGTH TEST :
2.5Un U≤200V | U+250V 200<U≤500 | 1.5U 500<U<1000 | 1.2U U≥1000
for 5s with 50mA max charging current

QUICK REFERENCE DATA

	0402	0603	0805	1111	1206	1210	1808	1812	1825	2220	2225	2525	2825	3033	3640	4040	5440
Min	0.1 pF	0.1 pF	0.1 pF	0.1 pF	0.4 pF	0.4 pF	1.0 pF	1.0 pF	1.0 pF	1.0 pF	1.0 pF	1.0 pF	4.7 pF	10 pF	10 pF	10 pF	10 pF
10V	2.2 nF	27 nF	47 nF	15 nF	220 nF	220 nF	22 nF	220 nF	100 nF	470 nF	100 nF	100 nF	120 nF	150 nF	220 nF	270 nF	330 nF
25V	1.5 nF	10 nF	47 nF	15 nF	220 nF	150 nF	22 nF	220 nF	100 nF	470 nF	100 nF	100 nF	120 nF	150 nF	220 nF	270 nF	330 nF
50V	330 pF	2.2 nF	10 nF	15 nF	22 nF	47 nF	22 nF	100 nF	82 nF	150 nF	100 nF	100 nF	120 nF	150 nF	220 nF	270 nF	330 nF
63V	330 pF	2.2 nF	10 nF	15 nF	22 nF	47 nF	22 nF	100 nF	82 nF	150 nF	100 nF	100 nF	120 nF	150 nF	220 nF	270 nF	330 nF
100V	220 pF	1.2 nF	3.9 nF	15 nF	10 nF	15 nF	22 nF	33 nF	82 nF	82 nF	100 nF	100 nF	120 nF	150 nF	220 nF	270 nF	330 nF
200V	180 pF	1.0 nF	3.3 nF	15 nF	8.2 nF	15 nF	18 nF	33 nF	68 nF	68 nF	82 nF	100 nF	120 nF	150 nF	220 nF	270 nF	330 nF
250V		560 pF	2.2 nF	12 nF	6.8 nF	12 nF	15 nF	27 nF	56 nF	56 nF	68 nF	82 nF	82 nF	120 nF	180 nF	220 nF	270 nF
500V		150 pF	560 pF	5.6 nF	1.8 nF	4.7 nF	4.7 nF	12 nF	27 nF	27 nF	33 nF	39 nF	47 nF	68 nF	82 nF	100 nF	120 nF
630V		68 pF	330 pF	3.3 nF	1.0 nF	2.7 nF	2.7 nF	8.2 nF	18 nF	18 nF	27 nF	27 nF	33 nF	47 nF	68 nF	68 nF	100 nF
1000V			150 pF	1.5 nF	560 pF	1.5 nF	1.2 nF	3.9 nF	10 nF	12 nF	15 nF	18 nF	18 nF	27 nF	39 nF	47 nF	56 nF
1500V				470 pF	180 pF	470 pF	470 pF	1.2 nF	2.7 nF	2.7 nF	3.9 nF	4.7 nF	4.7 nF	6.8 nF	10 nF	12 nF	15 nF
2000V					82 pF	220 pF	220 pF	680 pF	1.8 nF	1.8 nF	2.2 nF	2.7 nF	3.3 nF	4.7 nF	6.8 nF	8.2 nF	10 nF

Max values italic obtained with BME parts

ORDERING INFORMATION

H	0603	A	101	J	B	F	B	D03
SERIE	SIZE	DIELECTRIC	CAPACITANCE	TOLERANCE	VOLTAGE	TERMINATION	PACKAGING	SPECIAL PARAMETERS
High-Temperature	0402 0603 0805 1206 1210 1808 1812 1825 2220 2225 2525 2825 3033 3640 4040 5440	A = NPO	Expressed in picofarads (pF). The first two digits are significant, the third digit gives the number of noughts. Example : 102 = 1 000pF For special values R is used as decimal separator Example 12R7 = 12.7pF 1340R0 = 1340pF	A = ±0,5% if > 10pF and ±0,05pF if < 10pF B = ± 0,1pF C = ± 0,25pF D = ± 0,5pF E = 0.1% F = ± 1% G = ± 2% J = ± 5% K = ± 10%	Q = 10V J = 16V X = 25V A = 50V U = 63V B = 100V C = 200V P = 250V E = 500V F = 630V G = 1000V O = 1500V H = 2000V	X = Nickel Tin (up to 200°C) H = Dipped SnPb (up to 200°C) S = Dipped SAC (up to 200°C) I = Electrolytic SnPb (up to 200°C) F = Palladium-Silver (up to 250°C) W = Nickel Gold (up to 250°C) Q = Solderable Silver (up to 250°C)	B = Reel V = Bulk	- D03 = Burn-In 168H/125°C BM = BME Dxx = Reliability spec Exx = Sorting spec

For other sizes, voltage, tolerance contact us.

DIMENSIONS IN MILLIMETERS

	0402	0603	0805	1111	1206	1210	1808	1812	1825	2220	2225	2525	2825	3033	3640	4040	5440
Length (L)	1.00 ± 0.1	1.60 ± 0.2	2.00 ± 0.2	3.00 ± 0.2	3.20 ± 0.2	3.20 ± 0.2	4.60 ± 0.3	4.60 ± 0.3	4.60 ± 0.4	5.60 ± 0.4	5.60 ± 0.4	6.35 ± 0.4	7.10 ± 0.4	7.60 ± 0.4	9.15 ± 0.8	10.20 ± 0.8	13.70 ± 1.0
Width (W)	0.50 ± 0.1	0.80 ± 0.2	1.25 ± 0.2	3.00 ± 0.2	1.60 ± 0.2	2.50 ± 0.2	2.00 ± 0.2	3.20 ± 0.2	6.35 ± 0.3	5.10 ± 0.4	6.35 ± 0.4	6.35 ± 0.4	6.35 ± 0.4	8.40 ± 0.4	10.20 ± 0.8	10.20 ± 0.8	10.20 ± 1.0
Thickness max(T)	0.60	0.92	1.40	2.6	1.70	2.50	2.20	3.30	3.60	4.00	4.00	4.00	4.00	4.00	4.00	4.00	4.00
Termination (P)	Min	0.10	0.25	0.25	0.25	0.25	0.25	0.25	0.25	0.25	0.25	0.25	0.25	0.50	0.80	0.80	0.80
	Max	0.40	0.40	0.70	0.70	0.70	0.80	0.80	0.80	0.80	1.00	1.00	1.00	1.20	1.50	1.50	1.50

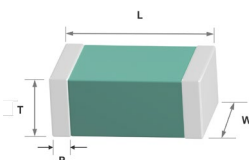

This document is subject to change without notice.



TYPICAL CHARACTERISTICS

NPO Temperature coefficient of capacitance

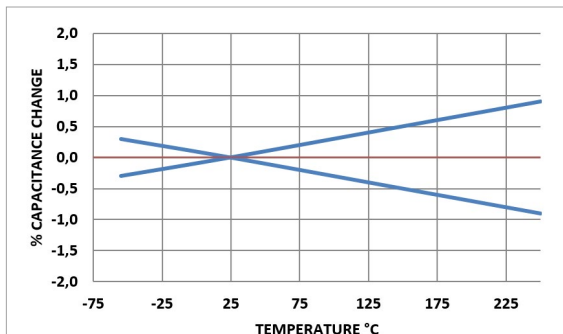

NPO Insulation resistance vs. temperature

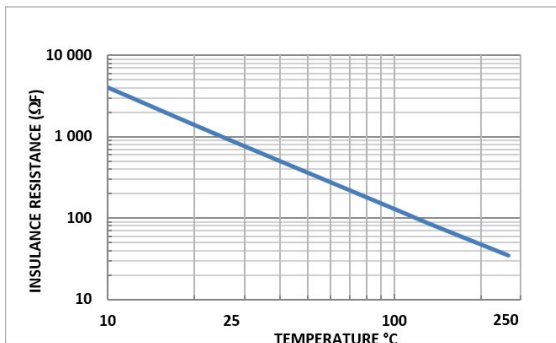

NPO Aging rate

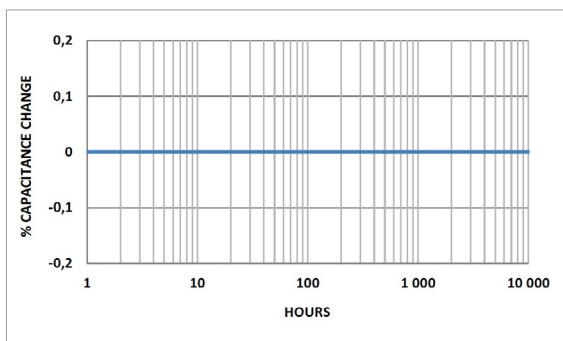

NPO Voltage coefficient of capacitance

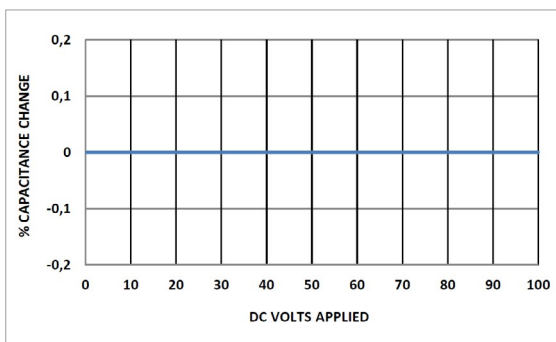

NPO Change of Capacitance with Frequency

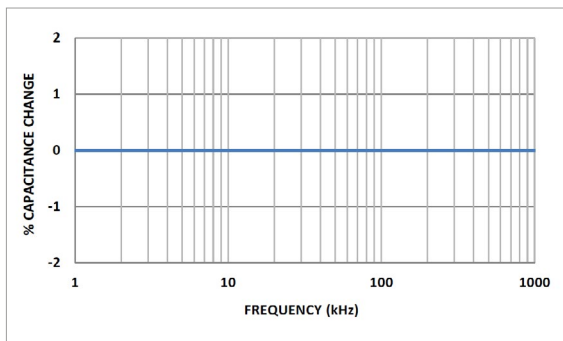

NPO Dissipation factor vs. frequency

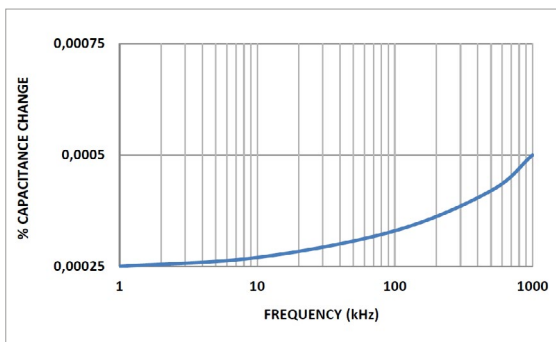

SMD High Temperature Class II

10V-2000V 200°C-250°C



SRT
MICROCÉRAMIQUE
MLCC CAPACITORS

APPLICATIONS

- Typical uses : timing, precision circuitry, filtering for High Temperature environment

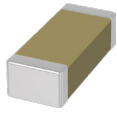

FEATURES

- Robust design for High Temperature durability
- ROHS Tin Termination or Non ROHS SnPb for use up to 200°C
- Gold/Silver-Palladium/Solderable Silver for use up to 250°C
- Custom voltage, package size, capacitance value on request
- 168H/125°C Burn-In option for maximum reliability
- Extended range for low time usage with reasonable reliability

ELECTRICAL PARAMETERS

ELECTRICAL CHARACTERISTICS :
at + 25°C unless otherwise specified

OPERATING TEMPERATURE :
- 55°C, + 250°C

TEMPERATURE COEFFICIENT :
± 15% with 0Vdc applied on -55°C/125°C
for 125°C/250°C range, refer to chart

DISSIPATION FACTOR :
≤ 2.5% at 1kHz for C ≥ 100pF

INSULATION RESISTANCE (IR) :
25°C/Un 10⁵ MOhm or 1000 Ohm-Farad whichever is less
200°C/Un 10⁴ MOhm or 100 Ohm-Farad whichever is less
250°C/Un 5x10³ MOhm or 50 Ohm-Farad whichever is less

DIELECTRIC STRENGTH TEST :
2.5Un U≤200V | U+250V 200<U≤500 | 1.5U 500<U<1000 | 1.2U U≥1000
for 5s with 50mA max charging current

QUICK REFERENCE DATA

	0603	0805	1206	1210	1812	2220	0603	0805	1206	1210	1812	2220	0603	0805	1206	1210	1812	2220	
	200°C	200°C	200°C	200°C	200°C	200°C	200°C	200°C	200°C	200°C	200°C	200°C	250°C	250°C	250°C	250°C	250°C	250°C	
	EXTENDED	EXTENDED	EXTENDED	EXTENDED	EXTENDED	EXTENDED	EXTENDED	EXTENDED	EXTENDED	EXTENDED	EXTENDED	EXTENDED	EXTENDED	EXTENDED	EXTENDED	EXTENDED	EXTENDED	EXTENDED	
Min	2.2 pF	6.8 pF	10 pF	10 pF	10 pF	33 pF	2.2 pF	6.8 pF	10 pF	10 pF	10 pF	33 pF	2.2 pF	6.8 pF	10 pF	10 pF	10 pF	10 pF	33 pF
10V	100 nF	1.0 μF	2.2 μF	10 μF	4.7 μF	22 μF	1.0 μF	4.7 μF	10 μF	22 μF	6.8 μF	47 μF	39 nF	100 nF	220 nF	390 nF	820 nF	1.8 μF	1.8 μF
25V	39 nF	100 nF	220 nF	390 nF	820 nF	1.8 μF	100 nF	1.0 μF	2.2 μF	10 μF	4.7 μF	22 μF	18 nF	68 nF	150 nF	270 nF	560 nF	1.2 μF	1.2 μF
50V	27 nF	82 nF	220 nF	330 nF	820 nF	1.8 μF	39 nF	100 nF	220 nF	390 nF	820 nF	1.8 μF	3.9 nF	15 nF	47 nF	120 nF	270 nF	560 nF	560 nF
63V	18 nF	68 nF	180 nF	270 nF	560 nF	1.2 μF	39 nF	100 nF	220 nF	390 nF	820 nF	1.8 μF	1.8 nF	8.2 nF	27 nF	68 nF	180 nF	470 nF	470 nF
100V	6.8 nF	27 nF	82 nF	180 nF	330 nF	820 nF	22 nF	82 nF	180 nF	330 nF	680 nF	1.5 μF	1.2 nF	5.6 nF	15 nF	47 nF	120 nF	330 nF	330 nF
200V	1.2 nF	5.6 nF	15 nF	47 nF	120 nF	330 nF	5.6 nF	22 nF	68 nF	150 nF	330 nF	680 nF	1.5 nF	1.5 nF	4.7 nF	12 nF	33 nF	82 nF	82 nF
250V	680 pF	2.7 nF	10 nF	27 nF	82 nF	220 nF	2.7 nF	12 nF	39 nF	100 nF	220 nF	560 nF		820 pF	2.7 nF	8.2 nF	22 nF	68 nF	68 nF
500V			1.5 nF	4.7 nF	12 nF	39 nF	470 pF	2.2 nF	6.8 nF	18 nF	39 nF	100 nF			470 pF	1.5 nF	4.7 nF	15 nF	15 nF
630V				820 pF	2.7 nF	8.2 nF	22 nF	1.2 nF	3.9 nF	10 nF	27 nF	82 nF						2.7 nF	8.2 nF
1000V					2.7 nF	8.2 nF			1.2 nF	3.3 nF	10 nF	27 nF						1.0 nF	2.7 nF
1500V					1.0 nF	3.3 nF					3.9 nF	12 nF							
2000V						1.2 nF					2.2 nF	5.6 nF							

Max values italic obtained with BME parts

ORDERING INFORMATION

H	0603	Y	101	J	B	W	B	D03
SERIE	SIZE	DIELECTRIC	CAPACITANCE	TOLERANCE	VOLTAGE	TERMINATION	PACKAGING	SPECIAL PARAMETERS
High-Température	0603 0805 1206 1210 1812 2220	Y= X7R	Expressed in picofarads (pF). The first two digits are significant, the third digit gives the number of noughts. Example : 102 = 1 000pF For special values R is used as decimal separator Example 12R7 = 12.7pF 134OR0 = 1340pF	J = ± 5% K = ± 10% M = ± 20%	Q = 10V J = 16V X = 25V Z = 35V A = 50V U = 63V B = 100V C = 200V P = 250V E = 500V F = 630V G = 1000V O = 1500V H = 2000V	X = Nickel Tin (up to 200°C) H = Dipped SnPb (up to 200°C) S = Dipped SAC (up to 200°C) I = Electrolytic SnPb (up to 200°C) F = Palladium-Silver (up to 250°C) W = Nickel Gold (up to 250°C) Q = Solderable Silver (up to 250°C)	B = Reel V = Bulk	- D03 = Burn-In 168H/125°C BM = BME Dxx = Reliability spec Exx = Sorting spec

For other sizes, voltage, tolerance contact us.

DIMENSIONS IN MILLIMETERS

	0603	0805	1206	1210	1812	2220
Length (L)	1.60 ± 0.2	2.00 ± 0.2	3.20 ± 0.2	3.20 ± 0.2	4.60 ± 0.3	5.60 ± 0.4
Width (W)	0.80 ± 0.2	1.25 ± 0.2	1.60 ± 0.2	2.50 ± 0.2	3.20 ± 0.2	5.10 ± 0.4
Thickness max(T)	0.92	1.40	1.70	2.50	3.30	4.00
Termination (P)	Min Max	0.25 0.40	0.25 0.70	0.25 0.70	0.25 0.80	0.25 0.80

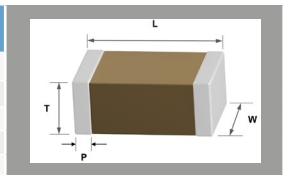

This document is subject to change without notice.



TYPICAL CHARACTERISTICS

HT Classe II Temperature coefficient of capacitance

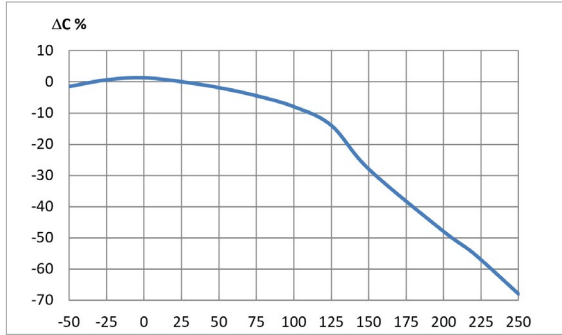

HT Classe II Insulation resistance vs. temperature

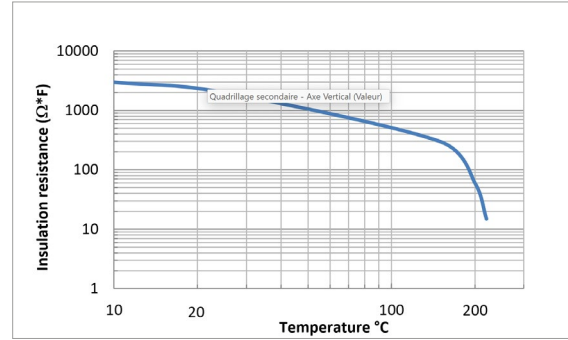

HT Classe II Aging rate

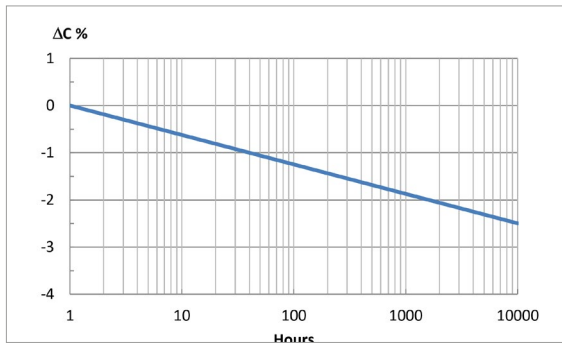

HT Classe II Voltage coefficient of capacitance

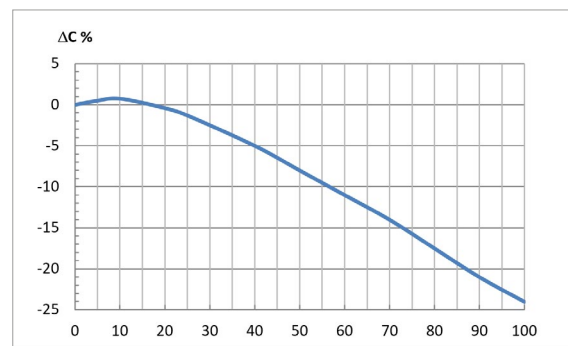

HT Classe II DF vs. temperature

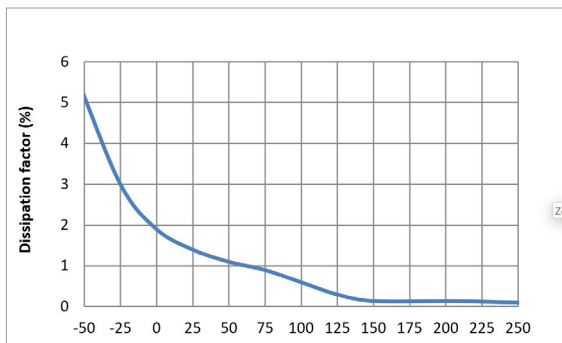



DESCRIPTION

Safety certified capacitors are designed for surge or lightning immunity in modern facsimile and other equipments. The capacitors of FK series are class X1/Y2 compliant, and the capacitors of FH series are class X2 compliant respectively. The green type capacitors in FK/FH series are manufactured by using environmentally friendly materials without lead or cadmium. The terminations are composed of plated nickel and pure tin to feature the superiority of leaching resistance during soldering.

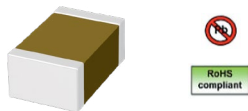

APPLICATIONS

- Modem
- Facsimile
- Telephone
- Other electronic equipment for lighting or surge protection and isolation

FEATURES

- High reliability and stability.
- Small size and high capacitance
- Safety standard approval by :
 - EN 60384-14 : 2013/A1 : 2016
 - IEC60384-14:2013/AMD1:2016
 - UL 60384-14(Ed 2.0)UL 62368-1 (2nd Edition)
- Certificate number :
 - UL R 50041666 & R 50359148 by TUV.
 - E346791(FOWX2/8) by UL, E231248 by UL
 - CQC20001247849 by CQC (FK series)
 - CQC20001247848 by CQC (FH series)
- Licenses :
 - ENEC-03020 (FK series)
 - ENEC-03021 (FH series)
- RoHS and HALOGEN compliant
- Manufactured by PDC

ELECTRICAL PARAMETERS

DIELECTRIC	COG	X7R
Size	1808, 1812 2211	1808, 1812, 2211, 2220
Rated Voltage	250 Vac	
Capacitance Range	X1/Y2 Class (Impulse 6KV) : 4pF - 100pF X1/Y2 Class (Impulse 5KV) : 3pF - 720pF X2 Class : 3pF - 1000pF	X1/Y2 Class : 100pF-4700pF X2 Class : 56000pF
Capacitance Tolerance	Cap.<10pF : D (±0.5pF) 10pF≤ Cap : F (±1%), G (±2%), J (±5%),K (±10%), M (±20%)	J (±5%) K (±10%) M (±20%)
DF	Cap.<30pF : Q≥400+20C Cap.≥30pF : Q≥1000	≤2.5%
Capacitance & DF- Test Condition	Measured at the condition of 30-70% related humidity.	
	For 25°C at ambient temperature	Preconditioning for Class II MLCC : Perform a heat treatment at 150 ±10°C for 1 hour, then leave in ambient condition for 24±2 hours before measurement
Insulation Resistance	≥100GΩ or RxC≥1000Ω-F, whichever is smaller	≥10GΩ or RxC≥5000Ω-F, whichever is smaller
Operating Temperature	-55°C to +125°C	
Temperature coefficient	±30ppm/°C	±15%
Termination	Cu or Ag/Ni/Sn (lead-free termination)	

ORDERING INFORMATION

FK	0805	Y	103	K	L	B	G
SERIES	SIZE	DIELECTRIC	CAPACITANCE	TOLERANCE	VOLTAGE	PACKAGING	SPECIAL
FK = Safety X1 & Y2 Series FH = Safety X2 Series	1206 1808 1812 2211 2220	A = COG Y = X7R	Expressed in picofarads (pF). The first two digits are significant, the third digit gives the number of noughts. Example : 102 = 1 000pF	D = ± 0.50pF F = ± 1% G = ± 2% J = ± 5% K = ± 10% M = ± 20%	T = 2.5KV L = 5KV 6 = 6KV	B = Reel V = Bulk	G = RoHS Compliant H = High Reliability Q = Anti-Arcing E = Anti Bending Z = Anti-Arcing + Anti-Bending Dxx = Reliability spec Exx = Sorting spec

DIMENSIONS IN MILLIMETERS

		1206	1808	1812	2211	2220
Length (L)		3.30 ±0.40	4.50 +0.6/-0.3	4.50 +0.6/-0.3	5.70 ±0.50	5.70 ±0.50
Width (W)		1.60 ±0.20	2.00 ±0.30	3.20 ±0.40	2.80 ±0.40	5.00 ±0.50
Thickness max (T)		1.35	2.20	2.80	3.10	3.10
Termination (P)	Min	0.25	0.25	0.25	0.30	0.30
	Max	0.75	0.75	0.75	0.90	0.90

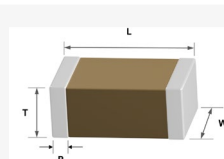



CAPACITANCE RANGE

Class		X1/Y2 (FK series)								X2 (FH series)					
Rated Voltage		250Vac													
Certificated		TUV / UL / CQC (IEC 60384-14)													
Dielectric		COG				X7R				COG		X7R			X7R
Size		1808	1812	2211	2211	1808	1812	2211	2220	1808	1812	1808	1812	2220	1206
Impulse		5KV			6KV	5KV				2.5KV					2.5KV
Code	Cap														
3R0	3.0 pF	R								R					
3R3	3.3 pF	R													
4R0	4.0 pF	R		W	W					R					
4R7	4.7 pF	R		W	W										
5R0	5.0 pF	R		W	W					R					
5R6	5.6 pF	R		W	W										
6R0	6.0 pF	R		W	W					R					
6R8	6.8 pF	R		W	W										
7R0	7.0 pF	R		W	W					R					
8R0	8.0 pF	R		W	W					R					
8R2	8.2 pF	R		W	W										
9R0	9.0 pF	R								R					
100	10 pF	R	P	W	W					R	P				
120	12 pF	R	P	W	W					R	P				
150	15 pF	R	P	W	W					R	P				
180	18 pF	R	P	W	W					R					
220	22 pF	R	P	W	W					R	P				
270	27 pF	R	P	W	W					R	P				
330	33 pF	R	P	W	W					R	P				
390	39 pF	T	P	W	W					T	P				
470	47 pF	T	P	W	W					T	P				
560	56 pF	T	P	W	W					T	P				
680	68 pF	T	P	W	Y					T	P				
820	82 pF	T	P	W	Y					T	P				
101	100 pF	W	P	W	Z	T*		T*		W	P				P
121	120 pF	W	P	Y		T*		T*		W	P				P
131	130 pF	W	P					T*							P
151	150 pF	W	P	Y		T*	T*	T*		W	P	T			P
161	160 pF	W	P	Y		T*		W*				T			P
181	180 pF	W	P	Y		T*	T*	T*	W*	W	P	T			P
221	220 pF	W	W	Y		T*	T*	T*	W*	W	P	T			P
271	270 pF	W	W	Y		W*	T*	W*	W*	W	R	T	T		P
301	300 pF		W									T	T		P
331	330 pF		W	Y		W*	T*	T*	W*	W	R	T	T		P
391	390 pF		W	Y		W*	T*	T*	W*	W	R	T	T		P
471	470 pF		W	Y		W*	T*	W*	W*	W	T	T	T		P
561	560 pF			Y		W*	T*	W*	W*	W	W	T	T		P
681	680 pF			Y		W*	W*	W*	W*	W	W	T	T		P
721	720 pF								W*	W			T		P
821	820 pF					W*	W*	W*	W*	W	Y	T	T		P
102	1.0 nF					W*	Y*	Y*	W*	W	Y	W	T		P
122	1.2 nF							Y*	Y*			W	T		
152	1.5 nF							Y*	Y*			W	W		
182	1.8 nF							Y*	Y*			W	W		
222	2.2 nF							Y*	Y*			W	Y		
272	2.7 nF							Z*	Y*				Y		
332	3.3 nF								Y*				Y		
392	3.9 nF								Y*				Y		
472	4.7 nF								Y*				Y		
562	5.6 nF												Y		
682	6.8 nF														
822	8.2 nF														
103	10 nF													Y	
123	12 nF													Y	
153	15 nF													Y	
183	18 nF													Y	
223	22 nF													Z	
273	27 nF													Z*	
333	33 nF													Z*	
393	39 nF													Z*	
473	47 nF													Z*	
563	56 nF													Z*	

Code	Thickness (mm)
P	1.25±0.10
R	1.40±0.15
T	1.60±0.20
W	2.00±0.20
Y	2.50±0.30
Z	2.80±0.30

* : Surface coating only

APPLICATIONS

RF and microwave communication (100MHz - 5GHz) for satellite communication, base station, wireless devices, radar

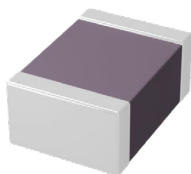

RoHS
compliant

ELECTRICAL PARAMETERS

ELECTRICAL CHARACTERISTICS:
at + 25°C unless otherwise specified

OPERATING TEMPERATURE:
- 55°C, + 125°C

TEMPERATURE COEFFICIENT:
± 30ppm

DISSIPATION FACTOR:
≤ 5.10⁻⁴ at 1Vrms and 1MHz for values ≤ 1000pF
≤ 5.10⁻⁴ at 1Vrms and 1KHz for values > 1000pF

INSULATION RESISTANCE (IR):
25°C/Un 10⁵ MOhm or 1000 Ohm-Farad whichever is less
125°C/Un 10⁴ MOhm or 100 Ohm-Farad whichever is less

DIELECTRIC STRENGTH TEST:
2.5Un U≤200V | U+250V 200<U≤500 | 1.5U 500<U<1000 | 1.2U U≥1000
for 5s with 50mA max charging current

QUICK REFERENCE DATA

	0402	0504	0603	0709	0805	1206	1210
MIN	0.1pF	0.1pF	0.1pF	0.1pF	0.1pF	0.3pF	0.3pF
50V	68pF	560pF	390pF	1,0nF	1,5nF	4,7nF	8,2nF
100V	47pF	560pF	390pF	1,0nF	1,5nF	4,7nF	8,2nF
200V	27pF	560pF	390pF	1,0nF	1,5nF	3,9nF	7,5nF
500V			100pF	100pF	470pF	1,2nF	3,3nF

ORDERING INFORMATION

1206	Q	560	F	E	X	B	-
SIZE	SIZE	DIELECTRIC	CAPACITANCE	TOLERANCE	VOLTAGE	PACKAGING	SPECIAL
0402 0504 0603 0805 1206 1210	Q = High Q	Expressed in picofarads (pF). The first two digits are significant, the third digit gives the number of noughts. Example : 102 = 1 000pF For special values R is used as decimal separator Example 12R7 = 12.7pF 1340R0 = 1340pF	A = ±0.05pF if < 10pF and 0.05% if > 10pF B = ± 0.1pF C = ± 0,25pF D = ± 0,5pF F = ± 1% G = ± 2% J = ± 5%	A = 50V B = 100V C = 200V P = 250V E = 500V	X = Nickel Tin C = Copper Tin (Non magnetic) F = Silver Palladium (Non magnetic) W = Nickel Gold Flash G = Nickel Gold Thick H = Dipped SnPb I = Electrolytic SnPb	B = Reel V = Bulk	- Dxx = Reliability spec Exx = Sorting spec

DIMENSIONS IN MILLIMETERS

		0402	0603	0709	0805	1206	1210
LENGTH (L)		1.00 ± 0.1	1.60 ± 0.1	1.80 ± 0.2	2.00 ± 0.2	3.20 ± 0.2	3.20 ± 0.2
WIDTH (W)		0.50 ± 0.1	0.80 ± 0.1	2.30 ± 0.2	1.25 ± 0.2	1.60 ± 0.2	2.50 ± 0.2
THICKNESS MAX (T)		0.60	0.90	2.90	1.40	1.70	1.70
TERMINATION (P)	MIN	0.10	0.25	0.25	0.25	0.25	0.25
	MAX	0.40	0.40	0.50	0.70	0.70	0.80

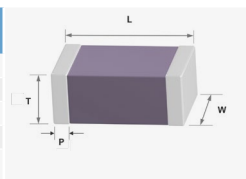

TYPICAL CHARACTERISTICS

Temperature coefficient of capacitance

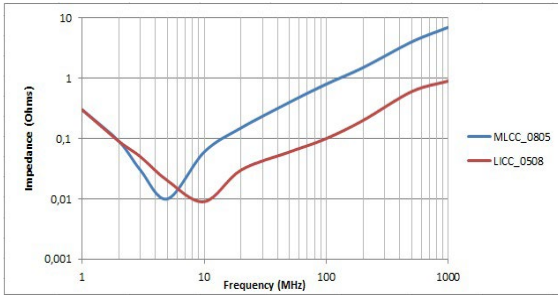

Series resonant frequency

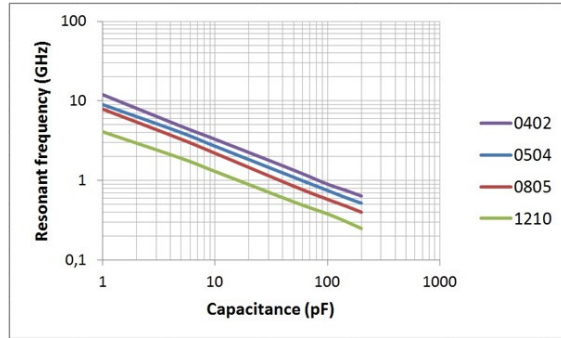

Q / Frequency - 0402, 200V

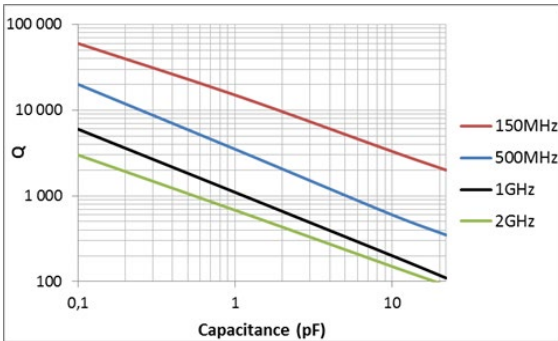

ESR / Frequency - 0402, 200V

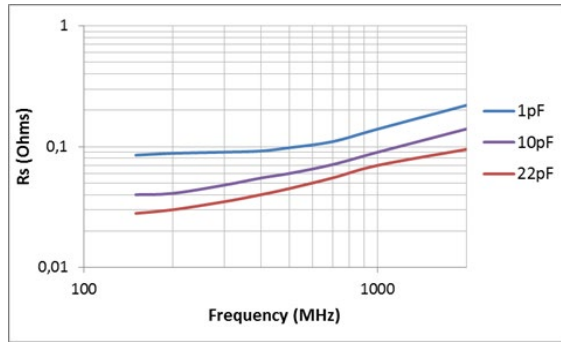

Q / Frequency - 0805, 1206, 200V

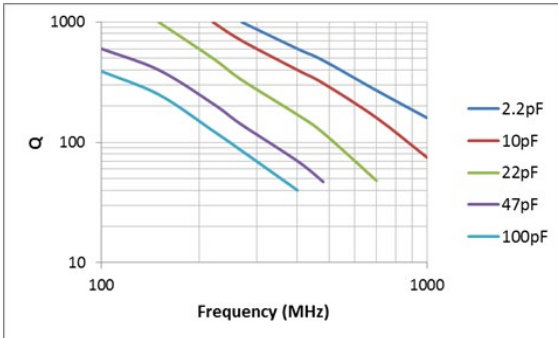

ESR / Frequency - 0805, 1206, 200V

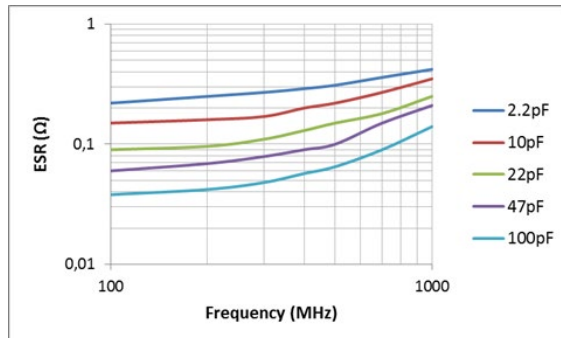

APPLICATIONS

- Lasers, CATV, RF Power Amplifiers
- Mixers, RF Instruments

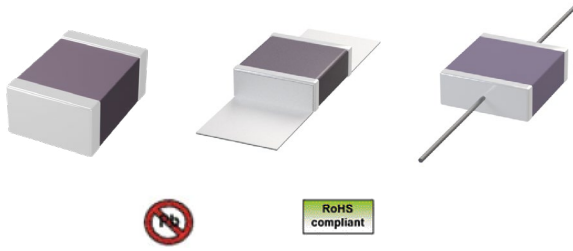

FEATURE

- Wide range of termination magnetic and non magnetic
- Microstrips and wires, axial, radial
- Equivalent to concurrent design
- Very low ESL/ESR. High current

ELECTRICAL PARAMETERS

ELECTRICAL CHARACTERISTICS:
at + 25°C unless otherwise specified

OPERATING TEMPERATURE:
- 55°C, + 125°C

TEMPERATURE COEFFICIENT:
± 30ppm

DISSIPATION FACTOR:
≤ 5.10⁻⁴ at 1Vrms at 1Vrms 1MHz for values ≤ 1000pF
≤ 5.10⁻⁴ at 1Vrms at 1Vrms 1KHz for values > 1000pF

INSULATION RESISTANCE (IR):
25°C/Un 10⁵ MOhm or 1000 Ohm-Farad whichever is less
125°C/Un 10⁴ MOhm or 100 Ohm-Farad whichever is less

DIELECTRIC STRENGTH TEST:
2.5Un U ≤ 200V | U + 250V 200 < U ≤ 500 | 1.5U 500 < U < 1000 | 1.2U U ≥ 1000
for 5s with 50mA max charging current

QUICK REFERENCE DATA

	0505	1111	2325	4040	7274
MIN	0.1pF	0.1pF	1pF	1pF	100pF
50V	1.0nF	5.1nF			
150V	620pF	1.0nF			
250V	100pF				
300V			3.3nF		
500V		680pF	3.0nF		
630V			2.4nF		
1000V		200pF	1.2nF	6.8nF	
1500V		47pF	470pF		
2000V				5.1nF	20nF
2500V			220pF	2.2nF	
3600V			51pF	390pF	
5000V				180pF	3nF
7200V					
8000V					220pF

ORDERING INFORMATION

2325	Q	560	F	E	X	B	-
SIZE	DIELECTRIC	CAPACITANCE	TOLERANCE	VOLTAGE	TERMINATION	PACKAGING	SPECIAL
0505 1111 2325 4040 7274	Q = High Q	Expressed in picofarads (pF). The first two digits are significant, the third digit gives the number of noughts. Example : 102 = 1000pF For special values R is used as decimal separator Example 12R7 = 12.7pF 1340R0 = 1340pF	A = ±0.05pF if < 10pF and 0.05% if > 10pF B = ± 0.1pF C = ± 0.25pF D = ± 0.5pF F = ± 1% G = ± 2% J = ± 5%	A = 50V B = 100V C = 200V P = 250V D = 300V E = 500V F = 630V G = 1000V O = 1500V H = 2000V T = 2500V I = 3000V M = 3600V K = 4000V L = 5000V S = 7200V 8 = 8000V	X = Nickel Tin C = Copper Tin (Non magnetic) F = Silver Palladium (Non magnetic) W = Nickel Gold Flash G = Nickel Gold Thick H = Dipped SnPb I = Electrolytic SnPb M = Microstrip A = Axial Ribbon R = Radial Ribbon U = Axial Wire V = Radial Wire CM = Microstrip (Non magnetic) CA = Axial Ribbon (Non magnetic) CR = Axial Ribbon (Non magnetic) CU = Axial Wire (Non magnetic) CV = Radial Wire (Non magnetic)	B = Reel V = Bulk	- Dxx = Reliability spec Exx = Sorting spec

This document is subject to change without notice.

DIMENSIONS IN MILLIMETERS

DESIGNATION	TERMINATION	0505	1111	2325	4040	7274
LENGTH (L)	X, C, F, W, G, H, I	1.40 ± 0.6	2.80 ± 0.5	5.85 ± 0.6	9.7 ± 0.8	18.9 ± 1.00
LENGTH (L)	M, CM, A, AR, R, CR		3.20 ± 0.5	6.30 ± 0.6	10.1 ± 0.8	18.9 ± 1.00
LENGTH (L)	U, UC, CU, CV		3.70 ± 0.5	6.30 ± 0.6	10.1 ± 0.8	
WIDTH (W)	ALL	1.40 ± 0.4	2.80 ± 0.4	6.35 ± 0.5	9.7 ± 0.8	19.1 ± 1.00
THICKNESS MAX (T)	ALL - M, CM	1.45	2.60	4.30	4.30	4.30
THICKNESS MAX (T)	M, CM		3.10	4.30	4.30	
TERMINATION (P)	MIN	ALL	0.10	0.20	0.25	0.80
	MAX	ALL	0.40	0.50	0.80	1.50
LENGTH RIBBON MIN (LR)	M, CM, A, AR, R, CR		7.00	13.00	20.00	20.00
WIDTH RIBBON (WR)	M, CM, A, AR, R, CR		2.40 ± 0.2	6.10 ± 0.2	8.90 ± 0.2	16.7 ± 0.4
THICKNESS RIBBON (TR)	M, CM, A, AR, R, CR		0.10	0.10	0.25	0.25
LENGTH WIRE MIN (LW)	U, UC, CU, CV		13.00	13.00	25.00	
DIAMETER WIRE (DW)	U, UC, CU, CV		0.41	0.81	0.81	

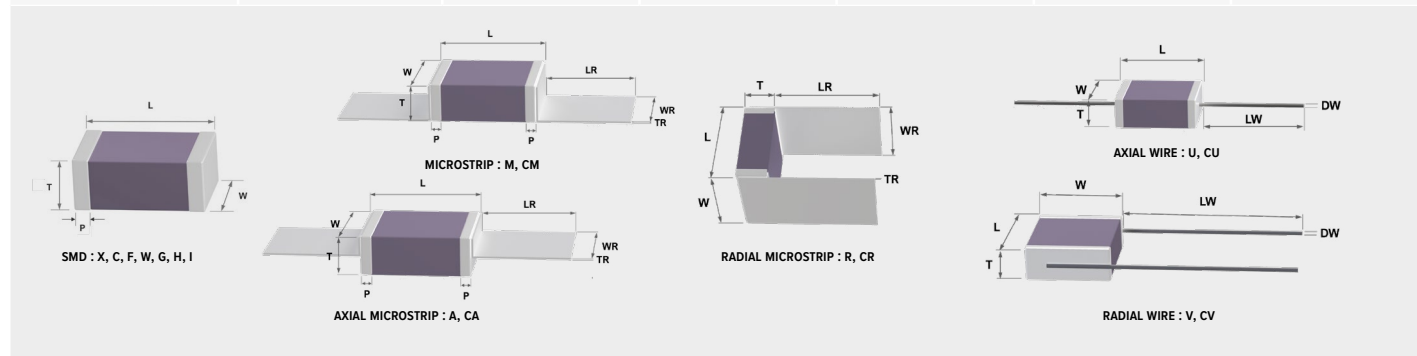

TYPICAL CHARACTERISTICS : 0505 TO 1111

0505

$ESR = f(F_{MHz})$

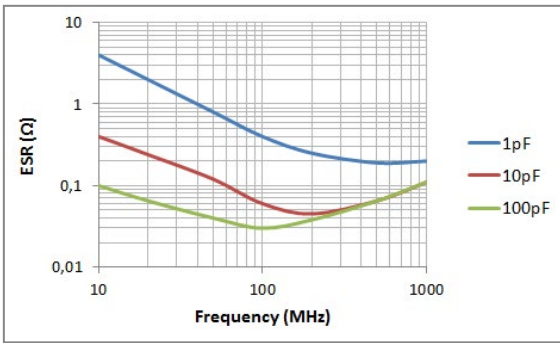

1111

$ESR = f(F_{MHz})$

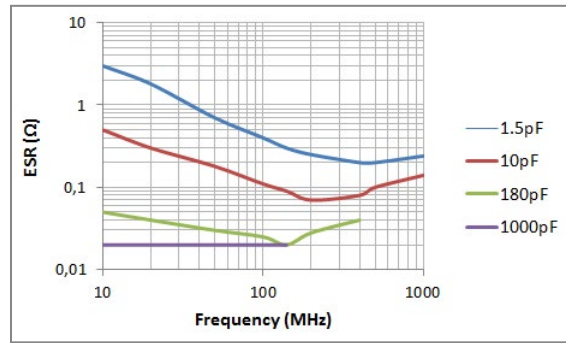

$Q \text{ Value} = f(F_{MHz})$

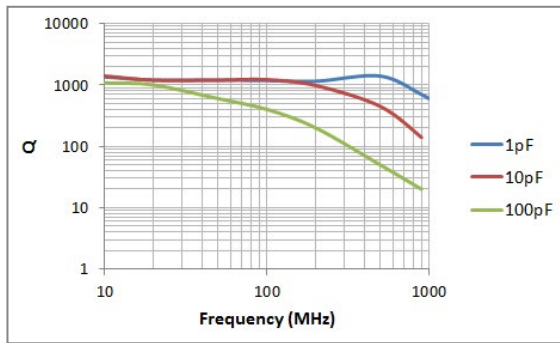

$Q \text{ Value} = f(F_{MHz})$

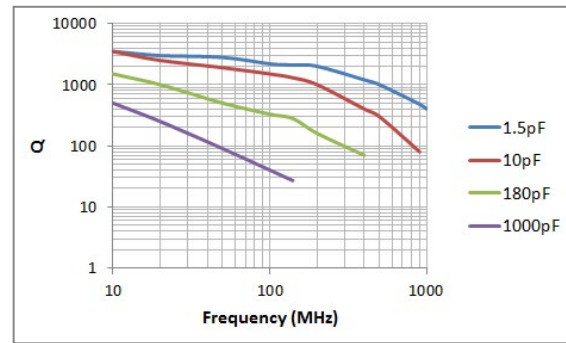

$\text{Resonant Frequency} = f(\text{CAP}_{pF})$

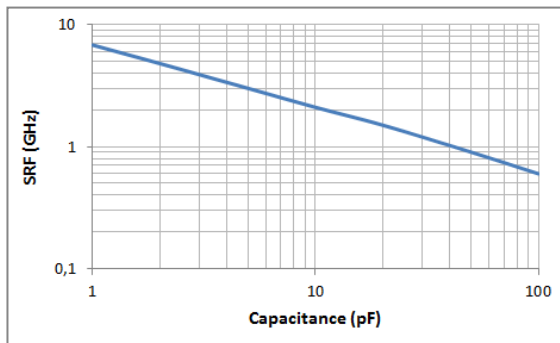

$\text{Resonant Frequency} = f(\text{CAP}_{pF})$

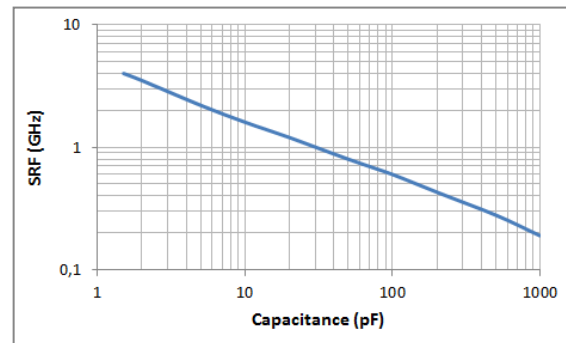

$I_{RMS} = f(\text{CAP}_{pF})$

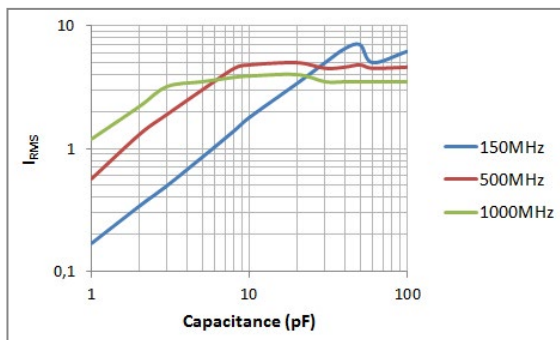

$I_{RMS} = f(\text{CAP}_{pF})$

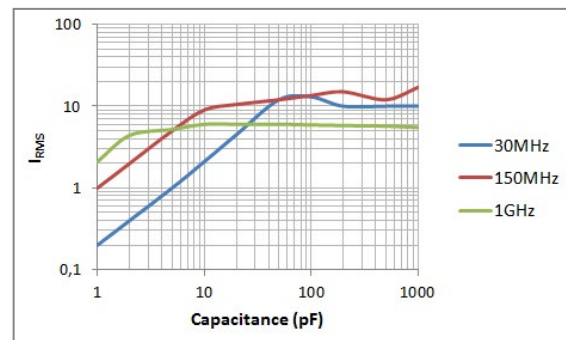

This document is subject to change without notice.

TYPICAL CHARACTERISTICS : 2325 TO 4040

2325

4040

ESR = f(F_{MHz})

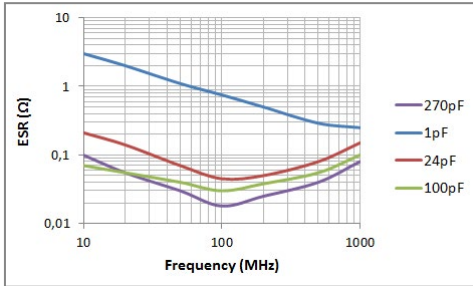

ESR = f(F_{MHz})

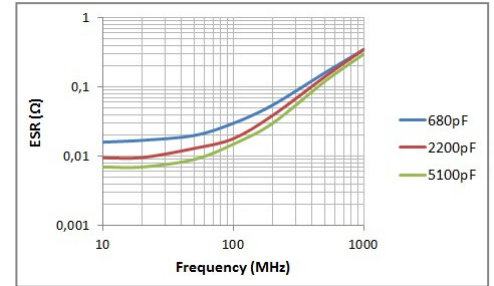
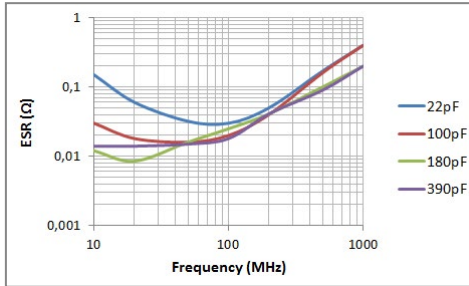

Q Value = f(F_{MHz})

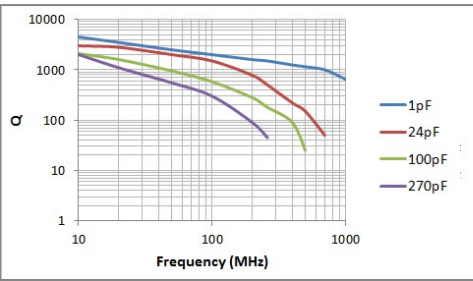

Q Value = f(F_{MHz})

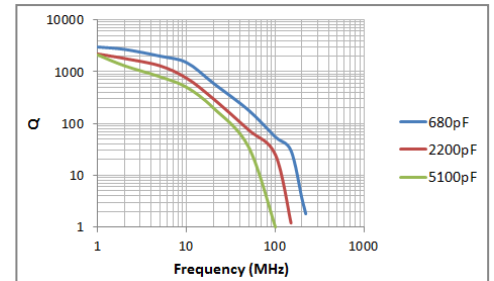
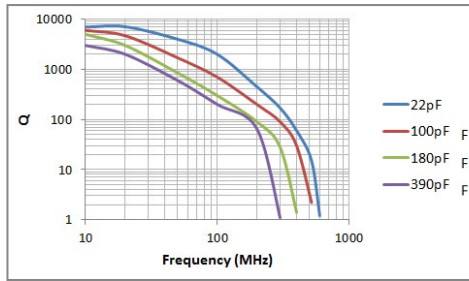

Resonant Frequency = f(CAP_{pF})

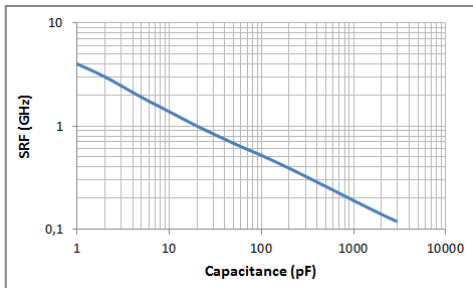

Resonant Frequency = f(CAP_{pF})

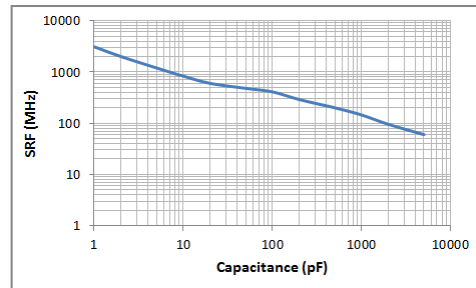

I_{RMS} = f(CAP_{pF})

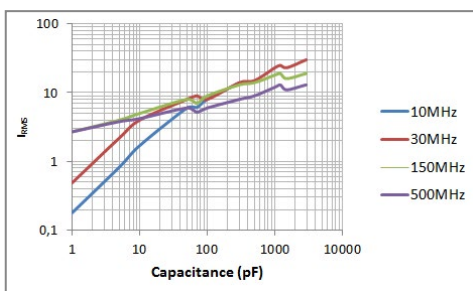

I_{RMS} = f(CAP_{pF})

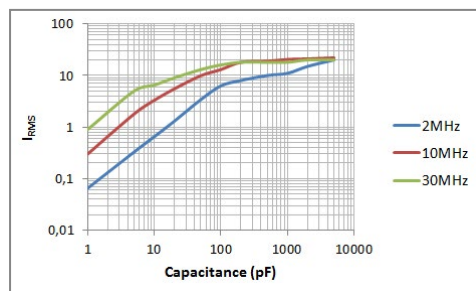

DESIGN KITS

SRT-Microc ermique is widening its High Q offer and propose design Kits with

KITS

P/N	DES	RANGE	VALUES	TOL
0603QXK-0R1-020	0603 HIGH Q 250V NISN TERMINATION (15PCS PER VALUE)	1.0pF -> 2.0pF	0.1pF 0.2pF 0.3pF 0.4pF 0.5pF 0.6pF 0.7pF 0.8pF 0.9pF 1.0pF 1.1pF 1.2pF 1.5pF 1.6pF, 1.8pF, 2.0pF	±0.1pF (B) ±0.25pF (C)
0603QXK-010-100		1.0pF -> 10pF	1.0pF 1.2pF 1.5pF 1.8pF 2.0pF 2.2pF 2.4pF 2.7pF 3.0pF 3.3pF 3.9pF 4.7pF 5.6pF 6.8pF 8.2pF 10pF	±0.25pF (C) ±0.50pF (D) ±5% (K)
0603QXK-100-101		10pF -> 100pF	10pF 12pF 15pF 18pF 20pF 22pF 24pF 27pF 30pF 33pF 39pF 47pF 56pF 68pF 82pF 100pF	±5% (K)
0709QXK-010-100	0709 HIGH Q 500V NISN TERMINATION (15PCS PER VALUE)	1.0pF -> 10pF	1.0pF 1.2pF 1.5pF 1.8pF 2.0pF 2.2pF 2.4pF 2.7pF 3.0pF 3.3pF 3.9pF 4.7pF 5.6pF 6.8pF 8.2pF 10pF	±0.25pF (C) ±0.50pF (D) ±5% (K)
0703QXK-100-101		10pF -> 100pF	10pF 12pF 15pF 18pF 20pF 22pF 24pF 27pF 30pF 33pF 39pF 47pF 56pF 68pF 82pF 100pF	±5% (K)

RF DECOUPLING X7R Vertical Electrodes Capacitor

16V-100V

APPLICATIONS

- Filtering, decoupling in Microelectronic applications

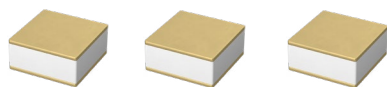

FEATURES

- Low Inductance Chip for Decoupling Integrated
- Circuit Able to work until 3GHz
- Wire Bondable Capacitor with Gold Termination
- Attachment Conductive Adhesive or AuSn Solder

ELECTRICAL PARAMETERS

ELECTRICAL CHARACTERISTICS:
at + 25°C unless otherwise specified

OPERATING TEMPERATURE:
- 55°C, + 125°C

TEMPERATURE COEFFICIENT:
± 15% with 0Vdc applied

DISSIPATION FACTOR:
≤ 2.5%

INSULATION RESISTANCE (IR):
25°C/Un 10⁵ MOhm or 1000 Ohm-Farad whichever is less
125°C/Un 10⁴ MOhm or 100 Ohm-Farad whichever is less

DIELECTRIC STRENGTH TEST:
Performed per method 301 MIL STD 202
Applied test voltages
≤ 100Vdc-rated : 250% of rated voltage

QUICK REFERENCE DATA

	0204	0303	0306	0404	0508
Min	10pF	10pF	10pF	10pF	100pF
16V	10nF	15nF	33nF	22nF	47nF
25V	5.6nF	15nF	33nF	22nF	47nF
50V	2.2nF	10nF	22nF	15nF	22nF
100V	1nF	6.8nF	8.2nF	8.2nF	22nF

ORDERING INFORMATION

SREV	0303	Y	103	K	X	W	W	-
STYLE	SIZE	DIELECTRIC	CAPACITANCE	TOLERANCE	VOLTAGE	TERMINATION	PACKAGING	SPECIAL
SREV	0204 0303 0306 0404 0508	Y = X7R	Expressed in picofarads (pF). The first two digits are significant, the third digit gives the number of noughts. Example : 102 = 1000pF For special values R is used as decimal separator Example 12R7 = 12.7pF 1340R0 = 1340pF	K = ± 10% M = ± 20%	J = 16V X = 25V A = 50V B = 100V	W = Gold	W = Waffle Pack	- Dxx = Reliability spec Exx = Sorting spec

DIMENSIONS IN MILLIMETERS

DESIGNATION	0204	0303	0306	0404	0508
Length (L)	0.51 ± 0.05	0.8 ± 0.05	0.8 ± 0.05	1.02 ± 0.1	1.25±0.1
Width (W)	1.02 ± 0.1	0.8 ± 0.05	1.50 ± 0.1	1.02 ± 0.1	2.1±0.1
THICKNESS (T)	Min	0.45	0.60	0.65	0.65
	Max	0.15	0.15	0.15	0.15

Gold Termination > 2.5µm.

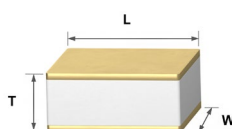



TYPICAL CHARACTERISTICS

X7R Capacitance and dissipation factor vs temperature

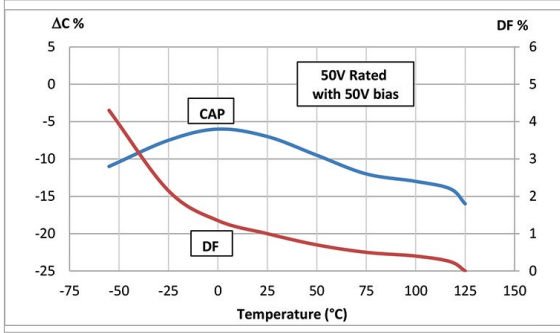

X7R Aging

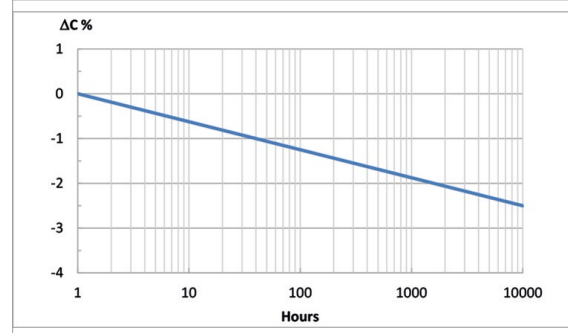

X7R Voltage coefficient of capacitance

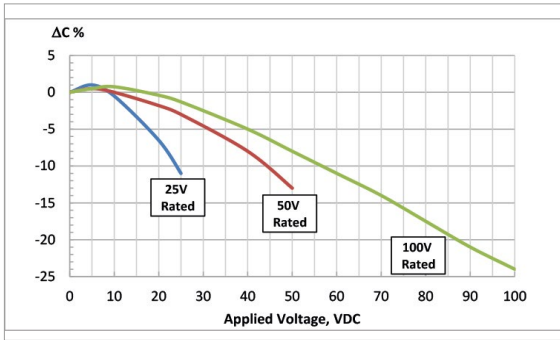

X7R Insulation resistance vs temperature

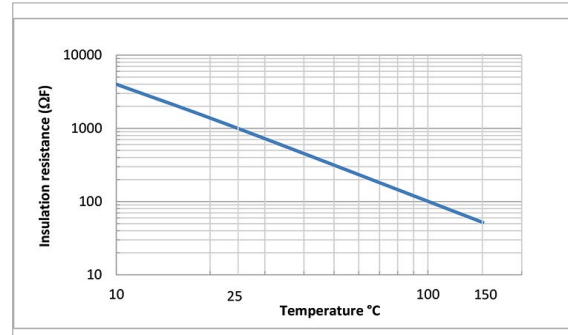

Impedance vs frequency

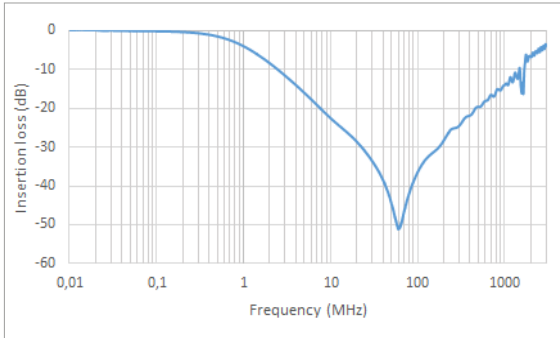

Impedance vs high frequency

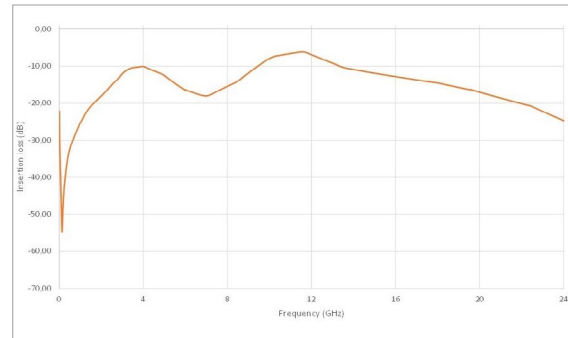



APPLICATIONS

- Microelectronic applications
- Wirebonding/glueing

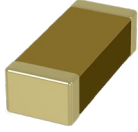

FEATURES

- Max 0.2µm Flash Au for Glueing (W termination)
- Min 2.5µm Thick Au for Wire Bonding/Glueing (G termination)

ELECTRICAL PARAMETERS

ELECTRICAL CHARACTERISTICS :
at + 25°C unless otherwise specified

OPERATING TEMPERATURE :
- 55°C, + 125°C

TEMPERATURE COEFFICIENT :
NPO : ± 30ppm
N2T : 2200 ± 350 ppm/C°
X7R : ± 15% with 0Vdc applied

AGING RATE :
X7R : 2% per decade

Dissipation Factor :
NPO : ≤ 1.10⁻³ at 1Vrms and 1MHz for values ≤ 1000pF
≤ 1.10⁻³ at 1Vrms and 1KHz for values > 1000pF
N2T : ≤ 1.10⁻³ at 1Vrms and 1MHz for values ≤ 1000pF
≤ 1.10⁻³ at 1Vrms and 1KHz for values > 1000pF
X7R : ≤ 0.025 at 1kHz

INSULATION RESISTANCE (IR) :
25°C/Un 10⁵ MOhm or 1000 Ohm-Farad whichever is less
125°C/Un 10⁴ MOhm or 100 Ohm-Farad whichever is less

DIELECTRIC STRENGTH TEST :
2.5Un U≤200V | U+250V 200<U≤500 | 1.5U 500<U<1000 | 1.2U U≥1000
for 5s with 50mA max charging current

ORDERING INFORMATION

0603	A	103	G	B	G	B	-
SIZE	DIELECTRIC	CAPACITANCE	TOLERANCE	VOLTAGE	TERMINATION	PACKAGING	SPECIAL PARAMETERS
0201 0306 0402 0504 0508 0603 0612 0805 1206 1210 1808 1812 1825 2220 2225	A = NPO P = N2T Y = X7R	Expressed in picofarads (pF). The first two digits are significant, the third digit gives the number of noughts. Example : 102 = 1 000pF For special values R is used as decimal separator Example 12R7 = 12.7pF 1340R0 = 1340pF	A = ±0.05pF if < 10pF and 0.05% if > 10pF B = ± 0.1pF C = ± 0,25pF D = ± 0,5pF F = ± 1% G = ± 2% J = ± 5% K = ± 10% M = ± 20%	R = 6.3V Q = 10V J = 16V X = 25V A = 50V U = 63V B = 100V C = 200V P = 250V E = 500V	W = Gold Flash G = Gold Thick	B = Reel V = Bulk	- Dxx = Reliability spec Exx = Sorting spec

For other sizes, voltage, tolerance contact us.

QUICK REFERENCE DATA

	0201		0306			0402			0504			0508			0603			0612			0805		
	NPO	X7R	NPO	N2T	X7R	NPO	N2T	X7R	NPO	N2T	X7R	NPO	N2T	X7R	NPO	N2T	X7R	NPO	N2T	X7R	NPO	N2T	X7R
Min	0.1 pF	100 pF	0.1 pF	0.3 pF	2.2 pF	0.1 pF	0.3 pF	2.2 pF	0.1 pF	0.3 pF	2.2 pF	0.1 pF	0.3 pF	2.2 pF	0.1 pF	0.3 pF	2.2 pF	0.1 pF	1.0 pF	6.8 pF	0.1 pF	1.0 pF	6.8 pF
6.3V	1.0 nF	33 nF	1.2 nF	5.6 nF	470 nF	2.2 nF	1.2 nF	1.0 µF	1.5 nF	6.8 nF	39 nF	3.9 nF	15 nF	2.2 µF	27 nF	5.6 nF	4.7 µF	8.2 nF	33 nF	4.7 µF	47 nF	15 nF	10 µF
10V	1.0 nF	33 nF	1.2 nF	5.6 nF	470 nF	2.2 nF	1.2 nF	470 nF	1.5 nF	5.6 nF	39 nF	3.9 nF	15 nF	2.2 µF	27 nF	5.6 nF	4.7 µF	8.2 nF	33 nF	2.2 µF	47 nF	15 nF	10 µF
16V	1.0 nF	33 nF	1.2 nF	5.6 nF	470 nF	2.2 nF	1.2 nF	220 nF	1.5 nF	5.6 nF	39 nF	3.9 nF	15 nF	2.2 µF	27 nF	5.6 nF	2.2 µF	8.2 nF	33 nF	1.0 µF	47 nF	15 nF	10 µF
25V	1.0 nF	10 nF	1.2 nF	5.6 nF	33 nF	2.2 nF	1.2 nF	220 nF	1.5 nF	5.6 nF	39 nF	3.9 nF	15 nF	2.2 µF	27 nF	5.6 nF	1.0 µF	8.2 nF	33 nF	470 nF	47 nF	15 nF	4.7 µF
50V	220 pF	1.5 nF	1.2 nF	4.7 nF	33 nF	1.5 nF	1.2 nF	100 nF	1.5 nF	5.6 nF	39 nF	3.9 nF	15 nF	100 nF	10 nF	5.6 nF	1.0 µF	8.2 nF	33 nF	220 nF	47 nF	15 nF	4.7 µF
63V	100 pF		1.2 nF	4.7 nF	33 nF	1.0 nF	1.2 nF	12 nF	1.5 nF	5.6 nF	39 nF	3.9 nF	15 nF	100 nF	10 nF	5.6 nF	100 nF	8.2 nF	33 nF	220 nF	33 nF	15 nF	1.0 µF
100V	100 pF		1.2 nF	4.7 nF	33 nF	1.0 nF	1.2 nF	10 nF	1.5 nF	5.6 nF	39 nF	3.9 nF	15 nF	100 nF	10 nF	5.6 nF	100 nF	8.2 nF	33 nF	220 nF	33 nF	15 nF	1.0 µF
200V			1.2 nF	4.7 nF	33 nF	330 pF	1.0 nF	6.8 nF	1.2 nF	5.6 nF	39 nF	3.9 nF	15 nF	100 nF	2.2 nF	5.6 nF	39 nF	8.2 nF	33 nF	220 nF	10 nF	15 nF	470 nF
250V			1.2 nF	4.7 nF	27 nF	330 pF	1.0 nF	5.6 nF	1.2 nF	5.6 nF	33 nF	3.9 nF	15 nF	82 nF	2.2 nF	5.6 nF	27 nF	8.2 nF	33 nF	180 nF	10 nF	15 nF	82 nF
500V			820 pF	2.2 nF	5.6 nF	180 pF	470 pF	1.2 nF	1.0 nF	2.7 nF	6.8 nF	3.3 nF	10 nF	39 nF	1.0 nF	2.7 nF	6.8 nF	8.2 nF	22 nF	82 nF	3.3 nF	10 nF	33 nF

Max values italic obtained with BME parts



QUICK REFERENCE DATA

	1206			1210			1808			1812			1825			2220			2225		
	NPO	N2T	X7R	NPO	N2T	X7R	NPO	N2T	X7R	NPO	N2T	X7R	NPO	N2T	X7R	NPO	N2T	X7R	NPO	N2T	X7R
Min	0.4 pF	4.7 pF	10 pF	0.4 pF	4.7 pF	10 pF	1.0 pF	4.7 pF	10 pF	1.0 pF	4.7 pF	10 pF	1.0 pF	10 pF	33 pF	1.0 pF	10 pF	33 pF	1.0 pF	10 pF	33 pF
6.3V	<i>220 nF</i>	39 nF	<i>22 μF</i>	<i>220 nF</i>	68 nF	<i>47 μF</i>	22 nF	82 nF	470 nF	220 nF	120 nF	<i>22 μF</i>	<i>100 nF</i>	270 nF	<i>10 μF</i>	470 nF	330 nF	<i>47 μF</i>	100 nF	390 nF	<i>10 μF</i>
10V	<i>220 nF</i>	39 nF	<i>22 μF</i>	<i>220 nF</i>	68 nF	<i>47 μF</i>	22 nF	82 nF	470 nF	220 nF	120 nF	<i>22 μF</i>	<i>100 nF</i>	270 nF	<i>10 μF</i>	470 nF	330 nF	<i>47 μF</i>	100 nF	390 nF	<i>10 μF</i>
16V	<i>220 nF</i>	39 nF	<i>22 μF</i>	<i>220 nF</i>	68 nF	<i>22 μF</i>	22 nF	82 nF	470 nF	220 nF	120 nF	<i>22 μF</i>	<i>100 nF</i>	270 nF	<i>10 μF</i>	470 nF	330 nF	<i>47 μF</i>	100 nF	390 nF	<i>10 μF</i>
25V	<i>220 nF</i>	39 nF	<i>10 μF</i>	<i>220 nF</i>	68 nF	<i>22 μF</i>	22 nF	82 nF	470 nF	220 nF	120 nF	<i>22 μF</i>	<i>100 nF</i>	270 nF	<i>10 μF</i>	470 nF	330 nF	<i>47 μF</i>	100 nF	390 nF	<i>10 μF</i>
50V	<i>220 nF</i>	39 nF	<i>10 μF</i>	<i>150 nF</i>	68 nF	<i>22 μF</i>	22 nF	82 nF	470 nF	220 nF	120 nF	<i>6.8 μF</i>	<i>100 nF</i>	270 nF	<i>10 μF</i>	470 nF	330 nF	<i>47 μF</i>	100 nF	390 nF	<i>10 μF</i>
63V	<i>100 nF</i>	39 nF	<i>2.2 μF</i>	<i>100 nF</i>	68 nF	<i>10 μF</i>	22 nF	82 nF	470 nF	150 nF	120 nF	<i>4.7 μF</i>	<i>100 nF</i>	270 nF	<i>10 μF</i>	330 nF	330 nF	<i>22 μF</i>	100 nF	390 nF	<i>10 μF</i>
100V	<i>100 nF</i>	39 nF	<i>2.2 μF</i>	<i>100 nF</i>	68 nF	<i>10 μF</i>	22 nF	82 nF	470 nF	150 nF	120 nF	<i>4.7 μF</i>	<i>100 nF</i>	270 nF	<i>10 μF</i>	330 nF	330 nF	<i>22 μF</i>	100 nF	390 nF	<i>10 μF</i>
200V	<i>22 nF</i>	39 nF	<i>220 nF</i>	<i>47 nF</i>	68 nF	<i>1.0 μF</i>	22 nF	82 nF	470 nF	100 nF	120 nF	<i>1.0 μF</i>	82 nF	270 nF	<i>2.2 μF</i>	150 nF	330 nF	<i>2.2 μF</i>	100 nF	390 nF	<i>2.7 μF</i>
250V	<i>22 nF</i>	39 nF	<i>220 nF</i>	<i>47 nF</i>	68 nF	<i>680 nF</i>	22 nF	82 nF	470 nF	100 nF	120 nF	<i>1.0 μF</i>	82 nF	270 nF	1.8 μF	150 nF	330 nF	<i>2.2 μF</i>	100 nF	390 nF	<i>2.7 μF</i>
500V	8.2 nF	27 nF	82 nF	15 nF	47 nF	180 nF	18 nF	56 nF	220 nF	33 nF	100 nF	<i>470 nF</i>	68 nF	220 nF	820 nF	68 nF	220 nF	<i>1.0 μF</i>	82 nF	270 nF	1.0 μF

Max values italic obtained with BME parts

DIMENSIONS IN MILLIMETERS

	0201	0306	0402	0504	0508	0603	0612	0805	1206	1210	1808	1812	1825	2220	2225
Length (L)	0.60 ± 0.03	0.80 ± 0.1	1.00 ± 0.1	1.25 ± 0.1	1.30 ± 0.2	1.60 ± 0.2	1.60 ± 0.2	2.00 ± 0.2	3.20 ± 0.2	3.20 ± 0.2	4.50 ± 0.2	4.50 ± 0.2	4.50 ± 0.3	5.60 ± 0.4	5.60 ± 0.4
Width (W)	0.30 ± 0.03	1.60 ± 0.1	0.50 ± 0.1	1.00 ± 0.1	2.00 ± 0.2	0.80 ± 0.2	3.20 ± 0.2	1.25 ± 0.2	1.60 ± 0.2	2.50 ± 0.2	2.00 ± 0.2	3.20 ± 0.2	6.35 ± 0.3	5.10 ± 0.4	6.35 ± 0.4
Thickness max(T)	0.35	0.92	0.60	1.00	2.00	0.92	3.00	1.40	1.70	2.50	2.10	3.30	3.60	4.10	4.10
Termination (P)	Min	0.10	0.10	0.10	0.25	0.25	0.25	0.25	0.25	0.25	0.25	0.25	0.25	0.25	0.25
	Max	0.20	0.30	0.30	0.30	0.40	0.40	0.70	0.70	0.80	0.80	0.80	0.80	0.80	1.00

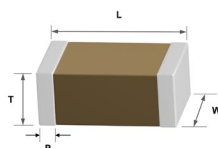



APPLICATIONS

Our FeedThru Capacitors provide better EMI performance than SMD components due to lower inductance, which results in broader frequency response for :

- Low speed signal lines
- Medium current power lines
- RF Immunity filter and amplifier gain filter

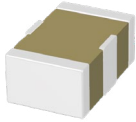

EQUIVALENT CIRCUIT

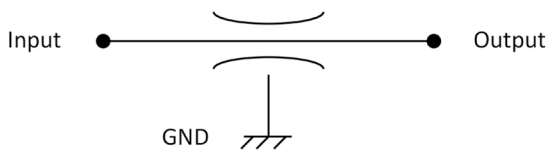

ELECTRICAL PARAMETERS

ELECTRICAL CHARACTERISTICS :
at + 25°C unless otherwise specified

OPERATING TEMPERATURE :
- 55°C, + 125°C

TEMPERATURE COEFFICIENT :
NPO : ± 30ppm
X7R : ± 15% with 0Vdc applied

AGING RATE :
X7R : 2% per decade

Dissipation Factor :
NPO : $\leq 1.10^{-3}$ at 1Vrms and 1MHz for values $\leq 1000\text{pF}$
 $\leq 1.10^{-3}$ at 1Vrms and 1KHz for values $> 1000\text{pF}$
X7R : ≤ 0.025 at 1kHz

INSULATION RESISTANCE (IR) :
25°C/Un 10^5 MOhm or 1000 Ohm-Farad whichever is less
125°C/Un 10^4 MOhm or 100 Ohm-Farad whichever is less

DIELECTRIC STRENGTH TEST :
2.5Un $U \leq 200\text{V}$ | $U + 250\text{V}$ $200 < U \leq 500$ | 1.5U $500 < U < 1000$ | 1.2U $U \geq 1000$
for 5s with 50mA max charging current

QUICK REFERENCE DATA

	0603		0805		1206		1806		1812		2220	
	NPO	X7R	NPO	X7R	NPO	X7R	NPO	X7R	NPO	X7R	NPO	X7R
MIN	1pF	47pF	10pF	100pF	22pF	220pF	22pF	220pF	100pF	1nF	100pF	1nF
50V	270pF	6.8nF	1.5nF	47nF	3.3nF	150nF	5.6nF	220nF	18nF	680nF	33nF	1.5µF
100V	270pF	5.6nF	1.5nF	47nF	3.3nF	100nF	4.7nF	150nF	15nF	470nF	33nF	1µF
200V	220pF	2.7nF	1nF	22nF	2.7nF	56nF	3.9nF	68nF	12nF	270nF	27nF	620nF
500V	47pF	750pF	390pF	3.9nF	1nF	10nF	1.5nF	18nF	6.8nF	100nF	15nF	270nF
1000V			120pF	1.8nF	390pF	5.6nF	560pF	6.8nF	3.3nF	47nF	10nF	150nF

CURRENT	NPO	ORDERING	0603	0805	1206	1806	1812	2220
		-	1A	2A	2A	2A	3A	6A
		1	500mA	500mA	500mA	500mA	3A	6A
	X7R	2	1A	2A	2A	/	/	

ORDERING INFORMATION

SERIES	0805	Y	103	K	A	X	-	B	-
SIZE	DIELECTRIC	CAPACITANCE	TOLERANCE	VOLTAGE	TERMINATION	CURRENT	PACKAGING	SPECIAL PARAMETERS	
MCF	0603 0805 1206 1806 1812 2220	A = NPO Y = X7R	Expressed in picofarads (pF). The first two digits are significant, the third digit give the number of noughts. Example : 102 = 1 000pF For special values R is used as decimal separator Example 12R7 = 12.7pF 1340R0 = 1340pF	J = ± 5% K = ± 10% M = ± 20%	A = 50V B = 100V C = 200V E = 500V G = 1000V	X = Nickel Tin F = Palladium-Silver P = Polymer Tin (Flex) C = Copper Tin (Non magnetic) W = Nickel Gold	- 1 2	B = Reel V = Bulk	- Dxx = Reliability spec Exx = Sorting spec T21 = Special B1 parameters

For other sizes contact us

DIMENSIONS (In millimeters)

	0603	0805	1206	1806	1812	2220
Length (L)	1.60 ± 0.2	2.00 ± 0.2	3.20 ± 0.2	4.50 ± 0.3	4.50 ± 0.3	5.70 ± 0.4
Width (W)	0.80 ± 0.1	1.25 ± 0.2	1.60 ± 0.2	1.60 ± 0.3	3.20 ± 0.2	5.00 ± 0.4
Thickness (T)	Max 0.9	1.25	1.60	1.60	3.20	4.00
Termination	B1 Min	0.30	0.50	0.40	0.70	1.10
	B1 Max	0.60	0.80	0.8	1.10	1.50
	B2 Min	0.15	0.15	0.15	0.15	0.15
	B2 Max	0.30	0.60	0.60	0.70	0.70

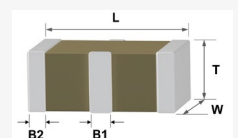

For P termination (Polymer type) add 0.10mm to Length (L) and 0.05 to Width (W) of the chip.

TYPICAL CHARACTERISTICS

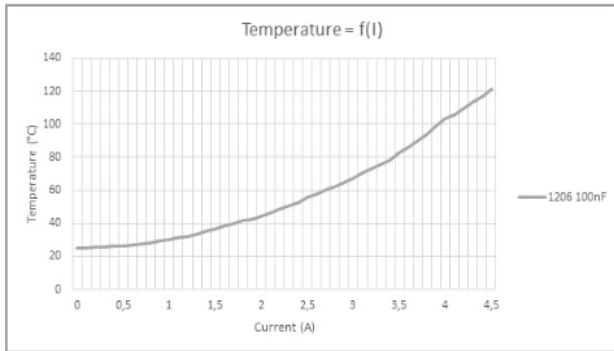
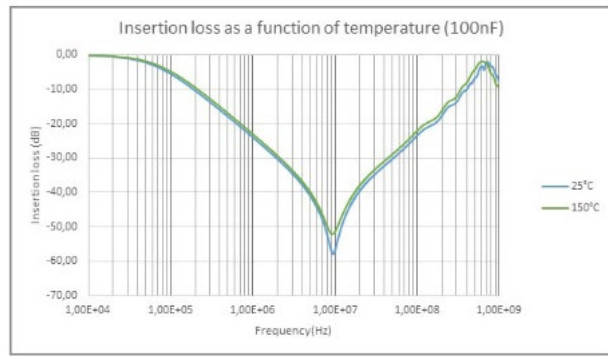

TYPICAL FOOTPRINT REFLOW SOLDERING

SIZE	FOOTPRINT DIMENSIONS IN mm						
	A	B	C	D	G	H	I
0603	2.30	0.80	0.45	1.40	0.60	0.40	1.50
0805	2.90	1.25	0.90	1.80	0.80	0.50	2.00
1206	4.10	1.60	0.90	2.40	1.00	0.70	3.00
1806	5.50	1.60	1.20	3.20	1.00	1.10	3.00
1812	5.50	3.30	1.20	3.90	1.50	1.20	4.80
2220	6.80	5.40	1.40	4.50	1.50	1.50	7.00

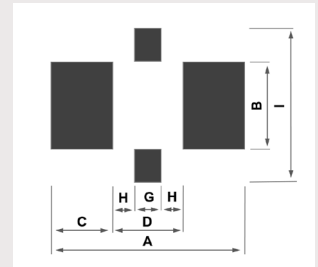

APPLICATIONS

- Flexible Quadripole Capacitor for filtering and decoupling



EQUIVALENT CIRCUIT

- Filtering

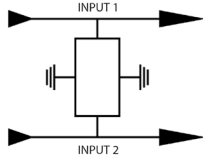

- Decoupling

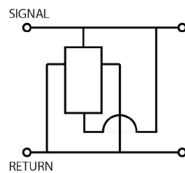

ELECTRICAL PARAMETERS

ELECTRICAL CHARACTERISTICS :
at + 25°C unless otherwise specified

OPERATING TEMPERATURE :
- 55°C, + 125°C

TEMPERATURE COEFFICIENT :
NPO : ± 30ppm
X7R : ± 15% with 0Vdc applied

AGING RATE :
X7R : 2% per decade

Dissipation Factor :
NPO : $\leq 1.10^{-3}$ at 1Vrms and 1MHz for values $\leq 1000\text{pF}$
 $\leq 1.10^{-3}$ at 1Vrms and 1KHz for values $> 1000\text{pF}$
X7R : ≤ 0.025 at 1kHz

INSULATION RESISTANCE (IR) :
25°C/Un 10^5 MOhm or 1000 Ohm-Farad whichever is less
125°C/Un 10^4 MOhm or 100 Ohm-Farad whichever is less

DIELECTRIC STRENGTH TEST :
2.5Un $U \leq 200\text{V}$ | $U + 250\text{V}$ $200 < U \leq 500$ for 5s with 50mA max charging current

QUICK REFERENCE DATA

	0603		0805		1206		1812		2220	
	NPO	X7R	NPO	X7R	NPO	X7R	NPO	X7R	NPO	X7R
MIN	1pF	47pF	1pF	100pF	10pF	220pF	100pF	470pF	100pF	470pF
50V	120pF	8.2nF	1.2nF	47nF	2.2nF	220nF	10nF	470nF	22nF	1µF
100V	120pF	6.2nF	1nF	39nF	1.8nF	100nF	6.8nF	330nF	18nF	750nF
200V	100pF	3.3nF	1nF	27nF	1.5nF	47nF	6.8nF	220nF	18nF	560nF
500V	27pF	680pF	220pF	7.5nF	470pF	12nF	3.3nF	100nF	10nF	270nF

ORDERING INFORMATION

M2F	0805	Y	103	K	A	X	B	
SERIES	SIZE	DIELECTRIC	CAPACITANCE	TOLERANCE	VOLTAGE	TERMINATION	PACKAGING	SPECIAL PARAMETERS
M2F	0603 0805 1206 1806 1812 2220	A = NPO Y = X7R	Expressed in picofarads (pF). The first two digits are significant, the third digit give the number of noughts. Example : 102 = 1 000pF For special values R is used as decimal separator Example 12R7 = 12.7pF 1340R0 = 1340pF	J = ± 5% K = ± 10% M = ± 20%	A = 50V B = 100V C = 200V E = 500V	X = Nickel Tin F = Palladium-Silver P = Polymer Tin (Flex) C = Copper Tin (Non magnetic) W = Nickel Gold	B = Reel V = Bulk	- Dxx = Reliability spec Exx = Sorting spec

For other sizes contact us

DIMENSIONS (In millimeters)

	0603	0805	1206	1812	2220	
Length (L)	1.60 ± 0.2	2.00 ± 0.2	3.20 ± 0.2	4.50 ± 0.3	5.70 ± 0.4	
Width (W)	0.80 ± 0.1	1.25 ± 0.2	1.60 ± 0.2	3.20 ± 0.2	5.00 ± 0.4	
Thickness (T)	Max 0.9	1.25	1.60	3.20	4.00	
Termination	B1 Min	0.30	0.50	0.70	1.10	
	B1 Max	0.60	0.80	1.10	1.50	
	B2 Min	0.15	0.15	0.15	0.15	0.15
	B2 Max	0.30	0.60	0.60	0.70	0.70

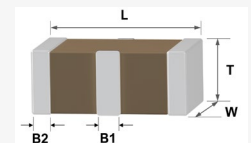

For P termination (Polymer type) add 0.10mm to Length (L) and 0.05 to Width (W) of the chip.

TYPICAL CHARACTERISTICS

Filtering

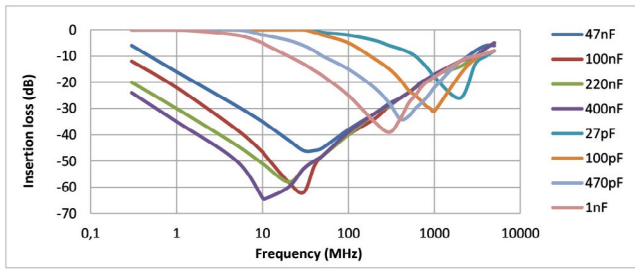

Decoupling

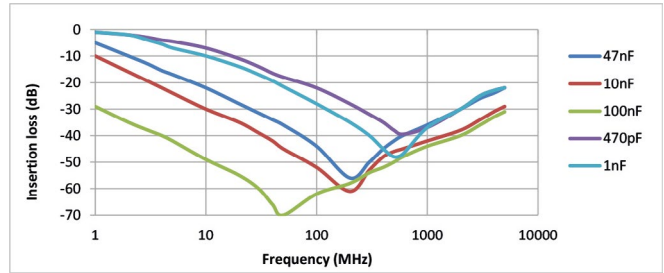

TYPICAL FOOTPRINT REFLOW SOLDERING

SIZE	FOOTPRINT DIMENSIONS IN mm						
	A	B	C	D	G	H	I
0603	2.30	0.80	0.45	1.40	0.60	0.40	1.50
0805	2.90	1.25	0.90	1.80	0.80	0.50	2.00
1206	4.10	1.60	0.90	2.40	1.00	0.70	3.00
1812	5.50	3.30	1.20	3.90	1.50	1.20	4.80
2220	6.80	5.40	1.40	4.50	1.50	1.50	7.00

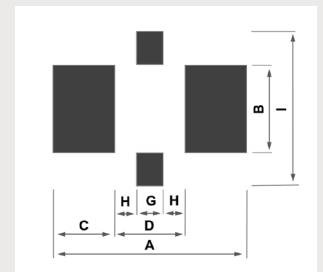



APPLICATIONS

Noise suppression in power lines for High Current Applications

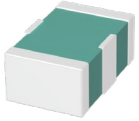

EQUIVALENT CIRCUIT

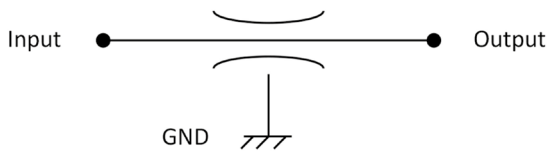

ELECTRICAL PARAMETERS

ELECTRICAL CHARACTERISTICS :
at + 25°C unless otherwise specified

OPERATING TEMPERATURE :
- 55°C, + 125°C

TEMPERATURE COEFFICIENT :
NPO : ± 30ppm
X7R : ± 15% with 0Vdc applied

AGING RATE :
X7R : 2% per decade

Dissipation Factor :
NPO : $\leq 1.10^{-3}$ at 1Vrms and 1MHz for values $\leq 1000\text{pF}$
 $\leq 1.10^{-3}$ at 1Vrms and 1KHz for values $> 1000\text{pF}$
X7R : ≤ 0.025 at 1kHz

INSULATION RESISTANCE (IR) :
25°C/Un 10^5 MOhm or 1000 Ohm-Farad whichever is less
125°C/Un 10^4 MOhm or 100 Ohm-Farad whichever is less

DIELECTRIC STRENGTH TEST :
 $2.5U_n U \leq 200V \mid U + 250V \ 200 < U \leq 500$ for 5s with 50mA max charging current

QUICK REFERENCE DATA (Max capacitance)

	1812		2220	
	NPO	X7R	NPO	X7R
MAX CURRENT	10A	2A-10A	20A	10A-20A
MIN	100pF	1nF	100pF	1nF
50V	10nF	220nF	22nF	470nF
100V	10nF	150nF	22nF	330 nF
200V	10nF	68nF	22nF	150nF
500V	5.6nF	47nF	10nF	68nF

ORDERING INFORMATION

MPF	0805	Y	103	K	A	X	B	SPECIAL PARAMETERS
SERIES	SIZE	DIELECTRIC	CAPACITANCE	TOLERANCE	VOLTAGE	TERMINATION	PACKAGING	
MPF	1812 2220	A = NPO Y = X7R	Expressed in picofarads (pF). The first two digits are significant, the third digit give the number of noughts. Example : 102 = 1 000pF For special values R is used as decimal separator Example 12R7 = 12.7pF 1340R0 = 1340pF	K = ± 10% M = ± 20%	A = 50V B = 100V C = 200V E = 500V	X = Nickel Tin F = Palladium-Silver P = Polymer Tin (Flex) C = Copper Tin (Non magnetic) W = Nickel Gold	B = Reel V = Bulk	- Dxx = Reliability spec Exx = Sorting spec

For other sizes contact us

DIMENSIONS (In millimeters)

		1812	2220
Length (L)		4.50 ± 0.3	5.70 ± 0.4
Width (W)		3.20 ± 0.2	5.00 ± 0.4
Thickness (T)	MAX	3.20	4.00
Termination	B1 Min	1.10	1.10
	B1 Max	1.50	1.50
	B2 Min	0.15	0.15
	B2 Max	0.70	0.70

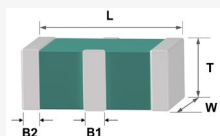

For P termination (Polymer type) add 0.10mm to Length (L) and 0.05 to Width (W) of the chip.

TYPICAL CHARACTERISTICS

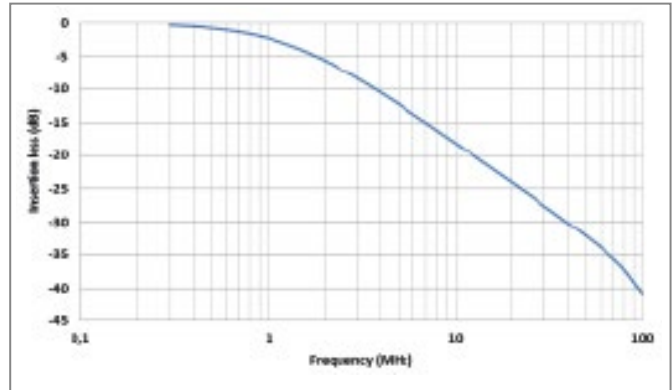
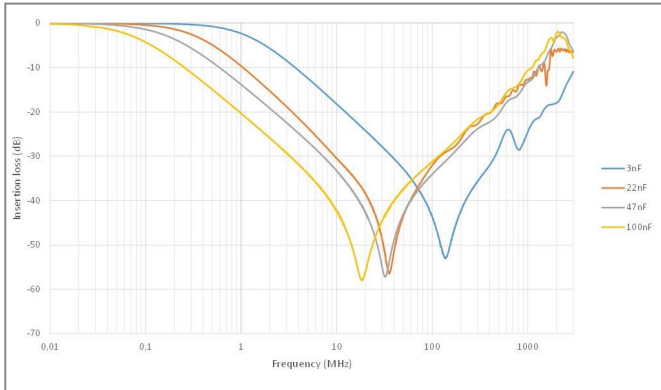

TYPICAL FOOTPRINT REFLOW SOLDERING

SIZE	FOOTPRINT DIMENSIONS IN mm						
	A	B	C	D	G	H	I
1812	5.50	3.30	1.20	3.90	1.50	1.20	4.80
2220	6.80	5.40	1.40	4.50	1.50	1.50	7.00

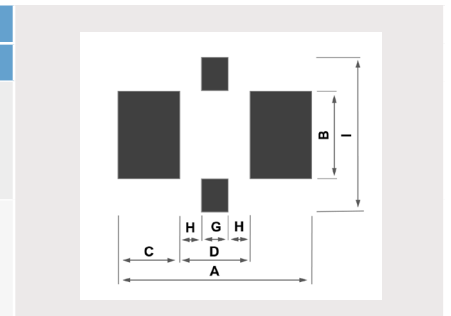

STACKED CAPACITOR High Power

NPO N2T X7R 16-1000V



SRT
MICROCÉRAMIQUE
MLCC CAPACITORS

APPLICATIONS

- Switch Mode Power Capacitor
- for Input / Output Filtering

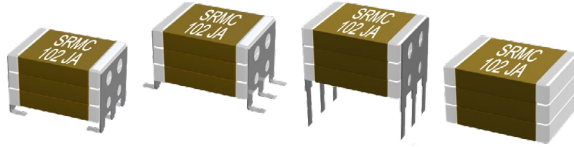

RoHS
compliant

FEATURES

- High reliability, 100% 48 hours burn-in
- Low ESR and ESL design
- High frequency switch
- Custom designs with any size, voltage, capacity, leads...
- Marking

ORDERING INFORMATION

SRMC	2225	Y	102	J	A	-	L	100	-	B	-
SERIE	SIZE	DIELECTRIC	CAPACITANCE	TOLERANCE	VOLTAGE	TERMINAISON	FORM	HEIGHT (H)	COATING	PACKAGING	SPECIAL
SRMC	1210 1812 1825 2220 2225 2825 3033 3640 4040 40100 5550 6080 6660 8060 80150	A = NPO P = N2T X = BX Y = X7R BY = 2C1	Expressed in picofarads (pF) The first two digits are significant, the third digit gives the number of noughts Example : 102 = 1 000pF For special values R is used as decimal separator Example 12R7 = 12.7pF 1340R0 = 1340pF	A = ±0.05pF if < 10pF and 0.05% if > 10pF B = ± 0,1pF C = ± 0,25pF D = ± 0,5pF F = ± 1% G = ± 2% J = ± 5% K = ± 10% M = ± 20%	J = 16 V X = 25 V A = 50 V U = 63 V B = 100 V C = 200 V P = 250 V E = 500 V F = 630 V G = 1 KV	- P : Polymer	J L D M U = 4 leads	020 030 040 050 060 070 080 090 100 110 120 130 140 160 180	- I = Conformal Coating H = Epoxy Coating	B = Reel V = Bulk	- BM = BME Dxx = Reliability spec Exx = Sorting spec

For J, L, M form, total height (T) is obtained by adding lead height (C/E) to specified chip height (H) in 1/10mm

For other sizes, voltage, tolerance contact us

DIMENSIONS J/L/D/M (In millimeters)

	1210	1812	1825	2220	2225	2825	3033	3640	4040	40100	5550	6080	6660	8060	80150
Lenght (L)	3.80 ± 0.3	5.10 ± 0.4	5.10 ± 0.4	6.20 ± 0.4	6.20 ± 0.4	7.70 ± 0.4	8.20 ± 0.4	9.75 ± 0.5	10.80 ± 0.5	10.80 ± 0.5	14.60 ± 0.5	15.80 ± 0.5	17.40 ± 0.5	20.90 ± 0.5	20.90 ± 0.5
Width (W)	2.50 ± 0.3	3.20 ± 0.4	6.35 ± 0.4	5.10 ± 0.4	6.35 ± 0.4	6.35 ± 0.4	8.40 ± 0.4	10.20 ± 0.5	10.20 ± 0.5	25.40 ± 0.5	12.70 ± 0.5	20.30 ± 0.5	15.20 ± 0.5	15.20 ± 0.5	38.10 ± 0.5
Nb of Leads	2	3	3	3	3	4	4	4	5	5	6	7	7	9	9
Min Height (T)	2.8	2.8	3.0	3.0	3.1	3.4	3.5	3.6	4.0	4.0	4.3	4.4	4.5	4.5	4.5
Max Height (T)	7.2	9.6	16.2	16.2	16.2	16.9	20.1	20.1	20.1	20.1	20.1	20.1	20.1	20.1	20.1
Lead Height (C)	1.3 ± 0.3	1.8 ± 0.3	1.8 ± 0.3	1.8 ± 0.3	1.8 ± 0.3	1.8 ± 0.3	1.8 ± 0.3	1.8 ± 0.3	1.8 ± 0.3	1.8 ± 0.3	1.8 ± 0.3	1.8 ± 0.3	1.8 ± 0.3	1.8 ± 0.3	1.8 ± 0.3
lead Lenght (D)	1.3 ± 0.3	1.4 ± 0.3	1.6 ± 0.3	1.8 ± 0.3	1.8 ± 0.3	1.8 ± 0.3	1.8 ± 0.3	1.8 ± 0.3	1.8 ± 0.3	1.8 ± 0.3	1.8 ± 0.3	1.8 ± 0.3	1.8 ± 0.3	1.8 ± 0.3	1.8 ± 0.3
Lead Height (E)	1.0 ± 0.3	1.3 ± 0.3	1.3 ± 0.3	1.3 ± 0.3	1.3 ± 0.3	1.3 ± 0.3	1.3 ± 0.3	1.3 ± 0.3	1.3 ± 0.3	1.3 ± 0.3	1.3 ± 0.3	1.3 ± 0.3	1.3 ± 0.3	1.3 ± 0.3	1.3 ± 0.3
Lead Lenght (F)	4.0 ± 1.0	4.0 ± 1.0	4.5 ± 1.0	5.0 ± 1.0	5.0 ± 1.0	6.0 ± 1.0	6.0 ± 1.0	6.0 ± 1.0	6.0 ± 1.0	6.0 ± 1.0	6.0 ± 1.0	6.0 ± 1.0	6.0 ± 1.0	6.0 ± 1.0	6.0 ± 1.0

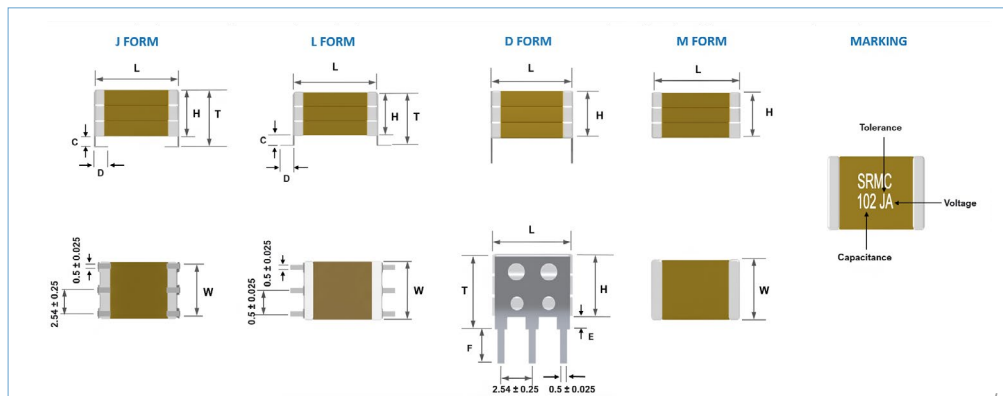

This document is subject to change without notice.

STACKED CAPACITOR High Power

NPO N2T X7R 16-1000V



SRT
MICROCÉRAMIQUE
MLCC CAPACITORS

DIMENSIONS 4 WIRES (In millimeters)

	3033	3640	5550	5550	5550	6080	6080	6660	8060	40100	80150
Lenght (L)	9.20 ± 0.5	11.15 ± 0.5	16.00 ± 0.5	16.00 ± 0.5	16.00 ± 0.5	17.20 ± 0.5	17.20 ± 0.5	18.80 ± 0.5	22.30 ± 0.5	12.20 ± 0.5	22.70 ± 0.5
Width (W)	8.40 ± 0.5	10.20 ± 0.5	12.70 ± 0.5	12.70 ± 0.5	12.70 ± 0.5	20.30 ± 0.5	20.30 ± 0.5	15.20 ± 0.5	15.20 ± 0.5	25.40 ± 0.5	38.10 ± 0.5
Lead Space (S)	8.40	10.15	15.00	15.00	15.00	16.20	16.20	17.80	21.30	11.20	21.50
Lead Width (S1)	5.08	7.62	7.62	10.16	15.24	10.16	15.24	10.16	10.16	27.94	30.48
Nb 2.54 sp (x)	2	3	3	4	6	4	6	4	4	11	12
Lead diam (d)	0.8	1.0	1.0	1.0	1.0	1.0	1.0	1.0	1.0	1.0	1.2
Min Height (H)	6	6	6	6	6	6	6	6	6	4	6
Max Height (H)	18	18	18	18	18	18	18	18	18	20.1	18
Lead Lenght (F)	25 ± 1.0	25 ± 1.0	25 ± 1.0	25 ± 1.0	25 ± 1.0	25 ± 1.0	25 ± 1.0	25 ± 1.0	25 ± 1.0	25 ± 1.0	25 ± 1.0

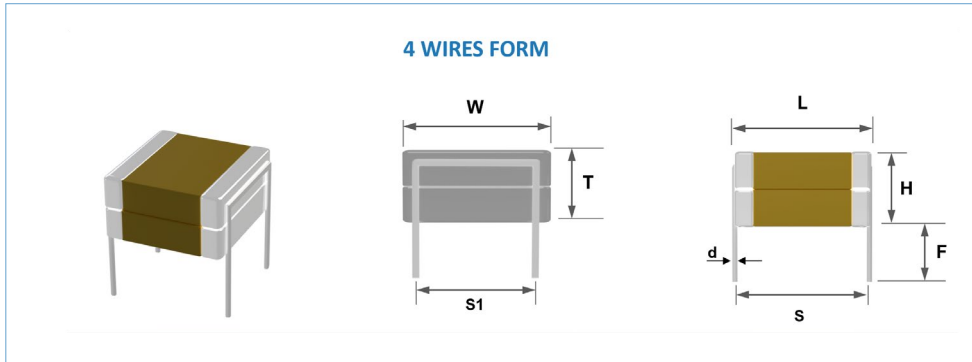

QUICK REFERENCE DATA (Max capacitance)

	1210			1812			1825			2220			2225			2825			Height H (1/10 mm)
	NPO	N2T	X7R	NPO	N2T	X7R	NPO	N2T	X7R	NPO	N2T	X7R	NPO	N2T	X7R	NPO	N2T	X7R	
min	12 nF	39 nF	150 nF	27 nF	82 nF	330 nF	56 nF	180 nF	820 nF	56 nF	180 nF	820 nF	68 nF	220 nF	1.0 µF	100 nF	330 nF	1.2 µF	
16V	220 nF	68 nF	22 µF	220 nF	150 nF	15 µF	82 nF	330 nF	2.2 µF	470 nF	330 nF	10 µF	100 nF	390 nF	3.3 µF	120 nF	470 nF	3.3 µF	020
	220 nF	220 nF	22 µF	470 nF	470 nF	33 µF	150 nF	1.0 µF	10 µF	1.0 µF	1.0 µF	22 µF	180 nF	820 nF	10 µF	270 nF	1.0 µF	5.6 µF	040
	470 nF	270 nF	47 µF	680 nF	560 nF	68 µF	330 nF	1.2 µF	18 µF	1.5 µF	1.2 µF	47 µF	390 nF	1.5 µF	18 µF	390 nF	1.5 µF	10 µF	060
							390 nF	1.8 µF	27 µF	1.8 µF	1.8 µF	68 µF	470 nF	1.8 µF	27 µF	470 nF	1.8 µF	12 µF	080
25V	220 nF	68 nF	22 µF	220 nF	150 nF	10 µF	82 nF	330 nF	2.2 µF	470 nF	330 nF	10 µF	100 nF	390 nF	3.3 µF	120 nF	470 nF	3.3 µF	020
	470 nF	220 nF	1.2 µF	68 nF	470 nF	2.7 µF	150 nF	1.0 µF	5.6 µF	180 nF	1.0 µF	6.8 µF	180 nF	820 nF	4.7 µF	270 nF	1.0 µF	5.6 µF	040
		270 nF	2.2 µF	150 nF	560 nF	3.9 µF	330 nF	1.2 µF	8.2 µF	330 nF	1.2 µF	8.2 µF	390 nF	1.5 µF	10 µF	390 nF	1.5 µF	10 µF	060
	220 nF						390 nF	1.8 µF	12 µF	390 nF	1.8 µF	12 µF	470 nF	1.8 µF	12 µF	470 nF	1.8 µF	12 µF	080
50V	150 nF	68 nF	10 µF	220 nF	150 nF	2.2 µF	82 nF	330 nF	2.2 µF	470 nF	330 nF	4.7 µF	100 nF	390 nF	3.3 µF	120 nF	470 nF	3.3 µF	020
	56 nF	220 nF	1.2 µF	68 nF	470 nF	2.7 µF	150 nF	1.0 µF	5.6 µF	180 nF	1.0 µF	6.8 µF	180 nF	820 nF	4.7 µF	270 nF	1.0 µF	5.6 µF	040
	68 nF	270 nF	2.2 µF	150 nF	560 nF	3.9 µF	330 nF	1.2 µF	8.2 µF	330 nF	1.2 µF	8.2 µF	390 nF	1.5 µF	10 µF	390 nF	1.5 µF	10 µF	060
							390 nF	1.8 µF	12 µF	390 nF	1.8 µF	12 µF	470 nF	1.8 µF	12 µF	470 nF	1.8 µF	12 µF	080
100V	100 nF	68 nF	4.7 µF	150 nF	150 nF	1.0 µF	82 nF	330 nF	2.2 µF	330 nF	330 nF	3.3 µF	100 nF	390 nF	3.3 µF	120 nF	470 nF	3.3 µF	020
	56 nF	220 nF	1.2 µF	68 nF	470 nF	2.7 µF	150 nF	1.0 µF	5.6 µF	180 nF	1.0 µF	6.8 µF	180 nF	820 nF	4.7 µF	270 nF	1.0 µF	5.6 µF	040
	68 nF	270 nF	2.2 µF	150 nF	560 nF	3.9 µF	330 nF	1.2 µF	8.2 µF	330 nF	1.2 µF	8.2 µF	390 nF	1.5 µF	10 µF	390 nF	1.5 µF	10 µF	060
							390 nF	1.8 µF	12 µF	390 nF	1.8 µF	12 µF	470 nF	1.8 µF	12 µF	470 nF	1.8 µF	12 µF	080
250V	18 nF	68 nF	390 nF	39 nF	150 nF	820 nF	82 nF	330 nF	1.8 µF	82 nF	330 nF	1.8 µF	100 nF	390 nF	2.2 µF	120 nF	470 nF	2.7 µF	020
	33 nF	220 nF	1.2 µF	68 nF	270 nF	1.5 µF	150 nF	680 nF	3.3 µF	180 nF	680 nF	3.9 µF	180 nF	820 nF	4.7 µF	270 nF	1.0 µF	5.6 µF	040
	68 nF	270 nF	1.5 µF	150 nF	560 nF	3.3 µF	330 nF	1.2 µF	6.8 µF	330 nF	1.2 µF	6.8 µF	390 nF	1.5 µF	10 µF	390 nF	1.5 µF	10 µF	060
							390 nF	1.5 µF	8.2 µF	390 nF	1.8 µF	10 µF	470 nF	1.8 µF	12 µF	470 nF	1.8 µF	12 µF	080
500V	15 nF	39 nF	180 nF	33 nF	82 nF	390 nF	68 nF	180 nF	820 nF	82 nF	220 nF	820 nF	100 nF	270 nF	1.0 µF	120 nF	330 nF	1.2 µF	020
	33 nF	82 nF	390 nF	68 nF	180 nF	390 nF	150 nF	390 nF	820 nF	150 nF	390 nF	820 nF	180 nF	470 nF	1.0 µF	220 nF	680 nF	1.2 µF	040
	68 nF	120 nF	560 nF	100 nF	270 nF	820 nF	220 nF	560 nF	1.8 µF	220 nF	560 nF	1.8 µF	270 nF	820 nF	2.2 µF	390 nF	1.0 µF	2.7 µF	060
							390 nF	820 nF	2.7 µF	390 nF	820 nF	2.7 µF	470 nF	1.0 µF	3.3 µF	470 nF	1.2 µF	3.9 µF	080
						470 nF	1.0 µF	3.3 µF	470 nF	1.0 µF	3.3 µF	560 nF	1.2 µF	6.8 µF	560 nF	1.5 µF	5.6 µF	100	
								4.7 µF						6.8 µF			8.2 µF	140	

This document is subject to change without notice.

STACKED CAPACITOR High Voltage

NPO N2T X7R 1KV-10KV



SRT
MICROCÉRAMIQUE
MLCC CAPACITORS

APPLICATIONS

- Switch Mode Power Capacitor
- for Input / Output Filtering

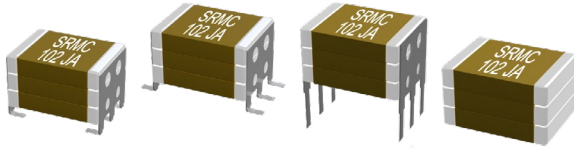

RoHS
compliant

FEATURES

- High reliability, 100% burn-in
- Low ESR and ESL design
- High frequency switch
- Custom designs with any size, voltage, capacity, leads...
- Marking

ELECTRICAL PARAMETERS

ELECTRICAL CHARACTERISTICS :
at + 25°C unless otherwise specified

OPERATING TEMPERATURE :
- 55°C, + 125°C

TEMPERATURE COEFFICIENT :
NPO : ± 30ppm
N2T : 2200 ± 350 ppm/°C
X7R : ± 15% with 0Vdc applied

DISSIPATION FACTOR:
NPO : ≤ 1.10⁻³ at 1Vrms and 1MHz for values ≤ 1000pF
 ≤ 1.10⁻³ at 1Vrms and 1KHz for values > 1000pF
N2T : ≤ 1.10⁻³ at 1Vrms and 1MHz for values ≤ 1000pF
 ≤ 1.10⁻³ at 1Vrms and 1KHz for values > 1000pF
X7R : ≤ 0.025 at 1kHz

INSULATION RESISTANCE (IR) :
25°C/Un 10⁵ MOhm or 1000 Ohm-Farad whichever is less
125°C/Un 10⁴ MOhm or 100 Ohm-Farad whichever is less

DIELECTRIC STRENGTH TEST :
1.2Un for 5s with 50mA max charging current

BURN IN :
48 hours 125°C 1.5 Un

ORDERING INFORMATION

SRMC	2225	Y	102	J	G		L	100	-	B	-
SERIES	SIZE	DIELECTRIC	CAPACITANCE	TOLERANCE	VOLTAGE	TERMINATION	FORM	HEIGHT (H)	COATING	PACKAGING	SPECIAL
SRMC	1812 1825 2220 2225 3033 3640 4040 40100 5550 6660 8060 80150	A = NPO P = N2T Y = X7R X = BX BY = 2C1	Expressed in picofarads (pF). The first two digits are significant, the third digit give the number of noughts. Example : 102 = 1 000pF For special values R is used as decimal separator Example 12R7 = 12.7pF 1340R0 = 1340pF	A = ±0.05pF if < 10pF and 0.05% if > 10pF B = ± 0.1pF C = ± 0.25pF D = ± 0.5pF F = ± 1% G = ± 2% J = ± 5% K = ± 10% M = ± 20%	G = 1KV H = 2KV I = 3KV L = 5KV 8 = 8KV 10 = 10KV	- P = Polymer	L J D M U = 4 leads	020 030 040 050 060 070 080 090 100 110 120 130 140 160 180	- I = Conformal Coating H = Epoxy-Coating	B = Reel V = Bulk	- BM = BME Dxx = Reliability spec Exx = Sorting spec

For J, L, M form, total height (T) is obtained by adding lead height (C/E) to specified chip height (H) in 1/10mm
For other sizes, voltage, tolerance contact us

DIMENSIONS (IN MILLIMETERS)

	1812	1825	2220	2225	2825	3033	3640	4040	40100	5550	6080	6660	8060	80150
Lenght (L)	5.10 ± 0.4	5.10 ± 0.4	6.20 ± 0.4	6.20 ± 0.4	7.70 ± 0.4	8.20 ± 0.4	9.75 ± 0.5	10.80 ± 0.5	10.80 ± 0.5	14.60 ± 0.5	15.80 ± 0.5	17.40 ± 0.5	20.90 ± 0.5	20.90 ± 0.5
Width (W)	3.20 ± 0.4	6.35 ± 0.4	5.10 ± 0.4	6.35 ± 0.4	6.35 ± 0.4	8.40 ± 0.4	10.20 ± 0.5	10.20 ± 0.5	25.40 ± 0.5	12.70 ± 0.5	20.30 ± 0.5	15.20 ± 0.5	15.20 ± 0.5	38.10 ± 0.5
Nb of Leads	3	3	3	3	4	4	4	5	5	6	7	7	9	9
Min Height (T)	2.8	3.0	3.0	3.1	3.4	3.5	3.6	4.0	4.0	4.3	4.4	4.5	4.5	4.5
Max Height (T)	9.6	16.2	16.2	16.2	16.9	20.1	20.1	20.1	20.1	20.1	20.1	20.1	20.1	20.1
Lead Height (C)	1.8 ± 0.3	1.8 ± 0.3	1.8 ± 0.3	1.8 ± 0.3	1.8 ± 0.3	1.8 ± 0.3	1.8 ± 0.3	1.8 ± 0.3	1.8 ± 0.3	1.8 ± 0.3	1.8 ± 0.3	1.8 ± 0.3	1.8 ± 0.3	1.8 ± 0.3
lead Lenght (D)	1.4 ± 0.3	1.6 ± 0.3	1.8 ± 0.3	1.8 ± 0.3	1.8 ± 0.3	1.8 ± 0.3	1.8 ± 0.3	1.8 ± 0.3	1.8 ± 0.3	1.8 ± 0.3	1.8 ± 0.3	1.8 ± 0.3	1.8 ± 0.3	1.8 ± 0.3
Lead Height (E)	1.3 ± 0.3	1.3 ± 0.3	1.3 ± 0.3	1.3 ± 0.3	1.3 ± 0.3	1.3 ± 0.3	1.3 ± 0.3	1.3 ± 0.3	1.3 ± 0.3	1.3 ± 0.3	1.3 ± 0.3	1.3 ± 0.3	1.3 ± 0.3	1.3 ± 0.3
Lead Lenght (F)	4.0 ± 1.0	4.5 ± 1.0	5.0 ± 1.0	5.0 ± 1.0	6.0 ± 1.0	6.0 ± 1.0	6.0 ± 1.0	6.0 ± 1.0	6.0 ± 1.0	6.0 ± 1.0	6.0 ± 1.0	6.0 ± 1.0	6.0 ± 1.0	6.0 ± 1.0

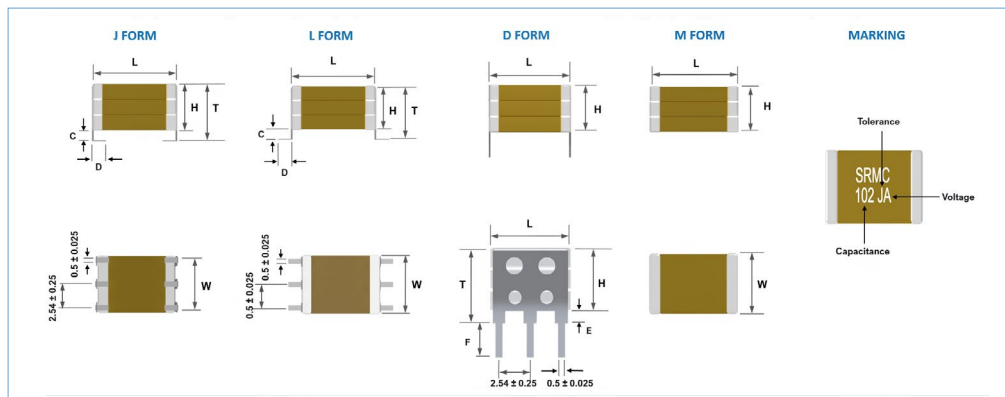

This document is subject to change without notice.

STACKED CAPACITOR High Voltage

NPO N2T X7R 1KV-10KV



SRT
MICROCÉRAMIQUE
MLCC CAPACITORS

DIMENSIONS 4 WIRES (In millimeters)

	3033	3640	5550	5550	5550	6080	6080	6660	8060	40100	80150
Lenght (L)	9.20 ± 0.5	11.15 ± 0.5	16.00 ± 0.5	16.00 ± 0.5	16.00 ± 0.5	17.20 ± 0.5	17.20 ± 0.5	18.80 ± 0.5	22.30 ± 0.5	12.20 ± 0.5	22.70 ± 0.5
Width (W)	8.40 ± 0.5	10.20 ± 0.5	12.70 ± 0.5	12.70 ± 0.5	12.70 ± 0.5	20.30 ± 0.5	20.30 ± 0.5	15.20 ± 0.5	15.20 ± 0.5	25.40 ± 0.5	38.10 ± 0.5
Lead Space (S)	8.40	10.15	15.00	15.00	15.00	16.20	16.20	17.80	21.30	11.20	21.50
Lead Width (S1)	5.08	7.62	7.62	10.16	15.24	10.16	15.24	10.16	10.16	27.94	30.48
Nb 2.54 sp (x)	2	3	3	4	6	4	6	4	4	11	12
Lead diam (d)	0.8	1.0	1.0	1.0	1.0	1.0	1.0	1.0	1.0	1.0	1.2
Min Height (H)	3.5	3.6	4.3	4.3	4.3	4.4	4.4	4.5	4.5	4	4.5
Max Height (H)	20.1	20.1	20.1	20.1	20.1	20.1	20.1	20.1	20.1	20.1	20.1
Lead Lenght (F)	25 ± 1.0	25 ± 1.0	25 ± 1.0	25 ± 1.0	25 ± 1.0	25 ± 1.0	25 ± 1.0	25 ± 1.0	25 ± 1.0	25 ± 1.0	25 ± 1.0

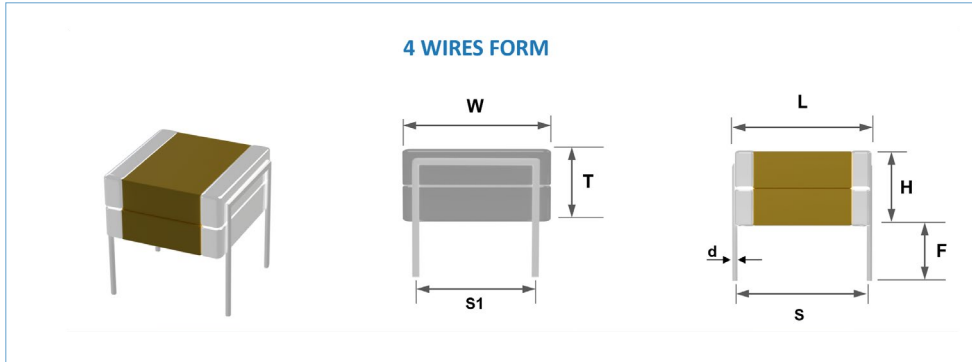

QUICK REFERENCE DATA (Max capacitance)

	1812			1825			2220			2225			3033			3640			Height H (1/10 mm)
	NPO	N2T	X7R	NPO	N2T	X7R	NPO	N2T	X7R	NPO	N2T	X7R	NPO	N2T	X7R	NPO	N2T	X7R	
min	12 pF	39 pF	1.0 nF	33 pF	100 pF	2.2 nF	82 pF	220 pF	470 pF	100 pF	220 pF	560 pF	180 pF	560 pF	1.2 nF	270 pF	820 pF	1.8 nF	
1KV	12 nF	22 nF	68 nF	27 nF	56 nF	150 nF	27 nF	56 nF	150 nF	33 nF	68 nF	220 nF	56 nF	120 nF	390 nF	82 nF	180 nF	560 nF	020
	18 nF	47 nF	120 nF	39 nF	100 nF	330 nF	39 nF	100 nF	390 nF	47 nF	120 nF	470 nF	82 nF	220 nF	820 nF	120 nF	330 nF	1.2 µF	040
	33 nF	47 nF	120 nF	68 nF	100 nF	330 nF	82 nF	100 nF	390 nF	100 nF	120 nF	470 nF	180 nF	220 nF	820 nF	270 nF	330 nF	1.2 µF	060
				120 nF	270 nF	680 nF	120 nF	330 nF	820 nF	150 nF	390 nF	1.0 µF	270 nF	680 nF	1.8 µF	390 nF	1.0 µF	2.7 µF	100
2KV	2.2 nF	3.9 nF	12 nF	4.7 nF	10 nF	33 nF	5.6 nF	10 nF	33 nF	6.8 nF	12 nF	39 nF	12 nF	22 nF	82 nF	18 nF	33 nF	120 nF	020
	4.7 nF	6.8 nF	22 nF	12 nF	15 nF	56 nF	12 nF	15 nF	68 nF	18 nF	22 nF	100 nF	27 nF	39 nF	180 nF	47 nF	56 nF	270 nF	040
	4.7 nF	12 nF	22 nF	12 nF	33 nF	56 nF	12 nF	33 nF	68 nF	18 nF	39 nF	100 nF	27 nF	82 nF	180 nF	47 nF	120 nF	270 nF	060
				22 nF	47 nF	120 nF	27 nF	47 nF	150 nF	33 nF	56 nF	180 nF	270 nF	56 nF	120 nF	390 nF	82 nF	180 nF	560 nF
3KV	820 pF	1.5 nF	5.6 nF	1.8 nF	3.3 nF	12 nF	1.8 nF	3.9 nF	12 nF	2.7 nF	4.7 nF	18 nF	12 nF	22 nF	82 nF	12 nF	27 nF	100 nF	020
	1.2 nF	2.7 nF	10 nF	2.7 nF	5.6 nF	27 nF	2.7 nF	6.8 nF	27 nF	3.9 nF	10 nF	33 nF	8.2 nF	18 nF	68 nF	12 nF	27 nF	100 nF	040
	2.2 nF	5.6 nF	10 nF	5.6 nF	12 nF	27 nF	5.6 nF	6.8 nF	27 nF	8.2 nF	10 nF	33 nF	15 nF	18 nF	68 nF	22 nF	27 nF	100 nF	060
				8.2 nF	18 nF	47 nF	8.2 nF	15 nF	56 nF	12 nF	18 nF	68 nF	27 nF	22 nF	33 nF	120 nF	33 nF	47 nF	180 nF
5KV	220 pF	470 pF	1.5 nF	560 pF	1.0 nF	3.3 nF	560 pF	1.2 nF	3.9 nF	680 pF	1.5 nF	4.7 nF	15 nF	27 nF	100 nF	2.2 nF	3.9 nF	15 nF	020
	390 pF	820 pF	2.7 nF	1.2 nF	2.2 nF	8.2 nF	1.5 nF	2.2 nF	10 nF	1.8 nF	3.3 nF	12 nF	3.9 nF	5.6 nF	22 nF	4.7 nF	8.2 nF	33 nF	040
	390 pF	820 pF	2.7 nF	1.2 nF	2.2 nF	8.2 nF	1.5 nF	2.2 nF	10 nF	1.8 nF	3.3 nF	12 nF	3.9 nF	5.6 nF	22 nF	4.7 nF	8.2 nF	33 nF	060
				2.2 nF	4.7 nF	15 nF	2.7 nF	4.7 nF	18 nF	3.9 nF	6.8 nF	27 nF	6.8 nF	12 nF	47 nF	10 nF	18 nF	68 nF	100
8KV	82 pF	120 pF	390 pF	180 pF	270 pF	1.0 nF	220 pF	390 pF	1.2 nF	270 pF	470 pF	1.5 nF	560 pF	1.0 nF	2.7 nF	680 pF	1.5 nF	3.9 nF	020
	150 pF	270 pF	1.0 nF	390 pF	680 pF	2.7 nF	390 pF	820 pF	2.7 nF	560 pF	1.2 nF	3.9 nF	1.0 nF	2.2 nF	6.8 nF	1.5 nF	3.3 nF	10 nF	040
	150 pF	270 pF	1.0 nF	390 pF	680 pF	2.7 nF	390 pF	820 pF	2.7 nF	560 pF	1.2 nF	3.9 nF	1.0 nF	2.2 nF	6.8 nF	1.5 nF	3.3 nF	10 nF	060
				820 pF	1.5 nF	5.6 nF	820 pF	1.8 nF	5.6 nF	1.0 nF	2.2 nF	8.2 nF	1.0 nF	2.2 nF	12 nF	2.7 nF	4.7 nF	10 nF	33 nF
10KV	39 pF	39 pF		100 pF	100 pF		120 pF	220 pF	680 pF	150 pF	220 pF	820 pF	330 pF	560 pF	1.8 nF	470 pF	820 pF	2.7 nF	020
	100 pF	100 pF		220 pF	270 pF		270 pF	470 pF	1.5 nF	390 pF	680 pF	1.8 nF	680 pF	1.2 nF	3.9 nF	1.0 nF	1.8 nF	5.6 nF	040
	100 pF	100 pF		220 pF	270 pF		270 pF	470 pF	1.5 nF	390 pF	680 pF	1.8 nF	680 pF	1.2 nF	3.9 nF	1.0 nF	1.8 nF	5.6 nF	060
				470 pF	560 pF		560 pF	1.0 nF	3.9 nF	820 pF	1.2 nF	5.6 nF	1.5 nF	2.7 nF	10 nF	2.2 nF	3.9 nF	15 nF	100
			680 pF	820 pF					1.2 nF	1.8 nF	6.8 nF	2.2 nF	3.9 nF	15 nF	3.3 nF	5.6 nF	22 nF	140	
																		180	

This document is subject to change without notice.

STACKED CAPACITOR High Voltage

NPO N2T X7R 1KV-10KV



SRT
MICROCÉRAMIQUE
MLCC CAPACITORS

QUICK REFERENCE DATA (Max capacitance)

	4040			40100			5550			6660			8060			80150			Height H (1/10 mm)
	NPO	N2T	X7R	NPO	N2T	X7R	NPO	N2T	X7R	NPO	N2T	X7R	NPO	N2T	X7R	NPO	N2T	X7R	
	330 pF	820 pF	1.8 nF	820 pF	2.2 nF	4.7 nF	560 pF	1.5 nF	3.3 nF	820 pF	2.2 nF	4.7 nF	1.0 nF	2.7 nF	5.6 nF	2.2 nF	6.8 nF	15 nF	
1KV	100 nF	180 nF	680 nF	220 nF	470 nF	1.5 µF	180 nF	330 nF	1.0 µF	220 nF	470 nF	1.5 µF	270 nF	560 nF	1.8 µF	680 nF	1.5 µF	4.7 µF	020
	150 nF	390 nF	1.5 µF	330 nF	1.0 µF	3.3 µF	220 nF	680 nF	2.2 µF	330 nF	820 nF	3.3 µF	390 nF	1.0 µF	3.9 µF	1.0 µF	2.7 µF	10 µF	040
	270 nF	390 nF	1.5 µF	680 nF	1.0 µF	3.3 µF	470 nF	680 nF	2.2 µF	680 nF	820 nF	3.3 µF	820 nF	1.0 µF	3.9 µF	2.2 µF	2.7 µF	10 µF	060
	390 nF	1.2 µF	2.7 µF	1.0 µF	2.7 µF	6.8 µF	680 nF	1.8 µF	4.7 µF	1.0 µF	2.7 µF	6.8 µF	1.2 µF	3.3 µF	8.2 µF	3.3 µF	8.2 µF	22 µF	100
	680 nF	1.5 µF	3.9 µF	1.8 µF	3.9 µF	10 µF	1.2 µF	2.7 µF	6.8 µF	1.8 µF	3.9 µF	10 µF	2.2 µF	4.7 µF	12 µF	5.6 µF	10 µF	33 µF	140
	820 nF	1.8 µF	5.6 µF	2.2 µF	4.7 µF	15 µF	1.5 µF	3.3 µF	10 µF	2.2 µF	4.7 µF	12 µF	2.7 µF	5.6 µF	15 µF	5.6 µF	12 µF	39 µF	180
2KV	18 nF	39 nF	120 nF	47 nF	100 nF	330 nF	33 nF	68 nF	220 nF	47 nF	100 nF	330 nF	56 nF	120 nF	390 nF	150 nF	270 nF	1.0 µF	020
	47 nF	68 nF	270 nF	120 nF	150 nF	680 nF	82 nF	120 nF	470 nF	120 nF	150 nF	680 nF	150 nF	180 nF	820 nF	390 nF	470 nF	2.2 µF	040
	47 nF	120 nF	270 nF	120 nF	330 nF	680 nF	82 nF	220 nF	470 nF	120 nF	330 nF	680 nF	150 nF	390 nF	820 nF	390 nF	1.0 µF	2.2 µF	060
	100 nF	180 nF	560 nF	220 nF	470 nF	1.5 µF	150 nF	330 nF	1.0 µF	220 nF	470 nF	1.5 µF	270 nF	560 nF	1.8 µF	680 nF	1.5 µF	4.7 µF	100
	150 nF	270 nF	820 nF	390 nF	680 nF	2.2 µF	220 nF	470 nF	1.5 µF	330 nF	680 nF	2.2 µF	390 nF	820 nF	2.7 µF	1.0 µF	1.8 µF	6.8 µF	140
	180 nF	390 nF	1.2 µF	470 nF	1.0 µF	2.7 µF	330 nF	680 nF	2.2 µF	470 nF	1.0 µF	2.7 µF	560 nF	1.2 µF	3.3 µF	1.5 µF	2.7 µF	8.2 µF	180
3KV	8.2 nF	15 nF	56 nF	18 nF	33 nF	120 nF	12 nF	22 nF	82 nF	18 nF	33 nF	120 nF	22 nF	39 nF	150 nF	56 nF	100 nF	390 nF	020
	12 nF	27 nF	100 nF	33 nF	68 nF	270 nF	22 nF	47 nF	180 nF	27 nF	68 nF	270 nF	39 nF	82 nF	330 nF	82 nF	220 nF	820 nF	040
	22 nF	27 nF	100 nF	56 nF	68 nF	270 nF	39 nF	47 nF	180 nF	56 nF	68 nF	270 nF	68 nF	82 nF	330 nF	180 nF	220 nF	820 nF	060
	39 nF	56 nF	220 nF	100 nF	150 nF	560 nF	68 nF	100 nF	390 nF	82 nF	150 nF	560 nF	100 nF	180 nF	680 nF	270 nF	390 nF	1.5 µF	100
	47 nF	82 nF	330 nF	120 nF	220 nF	820 nF	82 nF	150 nF	560 nF	120 nF	220 nF	820 nF	150 nF	270 nF	820 nF	390 nF	680 nF	2.2 µF	140
	68 nF	120 nF	390 nF	180 nF	270 nF	1.0 µF	120 nF	180 nF	680 nF	180 nF	220 nF	1.0 µF	220 nF	330 nF	560 nF	1.2 µF	560 nF	820 nF	180
5KV	2.2 nF	4.7 nF	18 nF	5.6 nF	12 nF	39 nF	3.9 nF	8.2 nF	27 nF	5.6 nF	12 nF	39 nF	6.8 nF	12 nF	47 nF	18 nF	33 nF	120 nF	020
	5.6 nF	10 nF	39 nF	15 nF	22 nF	100 nF	10 nF	18 nF	68 nF	15 nF	22 nF	100 nF	18 nF	27 nF	120 nF	39 nF	68 nF	270 nF	040
	5.6 nF	10 nF	39 nF	15 nF	22 nF	100 nF	10 nF	18 nF	68 nF	15 nF	22 nF	100 nF	18 nF	27 nF	120 nF	39 nF	68 nF	270 nF	060
	12 nF	18 nF	82 nF	27 nF	47 nF	180 nF	18 nF	33 nF	120 nF	27 nF	47 nF	180 nF	33 nF	56 nF	220 nF	82 nF	150 nF	560 nF	100
	18 nF	27 nF	120 nF	39 nF	68 nF	270 nF	27 nF	47 nF	180 nF	39 nF	68 nF	270 nF	47 nF	82 nF	330 nF	120 nF	220 nF	820 nF	140
	22 nF	39 nF	150 nF	56 nF	100 nF	390 nF	39 nF	68 nF	270 nF	56 nF	100 nF	390 nF	68 nF	120 nF	470 nF	180 nF	270 nF	1.2 µF	180
8KV	820 pF	1.5 nF	4.7 nF	2.2 nF	3.9 nF	12 nF	1.5 nF	2.7 nF	8.2 nF	1.8 nF	3.9 nF	12 nF	2.2 nF	4.7 nF	15 nF	5.6 nF	12 nF	33 nF	020
	1.5 nF	3.9 nF	12 nF	3.9 nF	10 nF	27 nF	2.7 nF	6.8 nF	22 nF	3.9 nF	8.2 nF	27 nF	4.7 nF	10 nF	33 nF	12 nF	27 nF	82 nF	040
	1.5 nF	3.9 nF	12 nF	3.9 nF	10 nF	27 nF	2.7 nF	6.8 nF	22 nF	3.9 nF	8.2 nF	27 nF	4.7 nF	10 nF	33 nF	12 nF	27 nF	82 nF	060
	3.3 nF	6.8 nF	22 nF	8.2 nF	18 nF	56 nF	5.6 nF	12 nF	39 nF	8.2 nF	18 nF	56 nF	10 nF	22 nF	68 nF	22 nF	56 nF	180 nF	100
	4.7 nF	12 nF	39 nF	12 nF	27 nF	82 nF	8.2 nF	18 nF	56 nF	12 nF	27 nF	82 nF	15 nF	33 nF	100 nF	39 nF	82 nF	270 nF	140
	8.2 nF	15 nF	47 nF	22 nF	39 nF	120 nF	15 nF	27 nF	82 nF	18 nF	39 nF	120 nF	22 nF	47 nF	150 nF	56 nF	100 nF	330 nF	180
10KV	470 pF	1.0 nF	2.7 nF	1.2 nF	2.2 nF	6.8 nF	820 pF	1.5 nF	4.7 nF	1.2 nF	2.2 nF	6.8 nF	1.5 nF	2.7 nF	8.2 nF	3.9 nF	6.8 nF	22 nF	020
	1.2 nF	2.2 nF	5.6 nF	2.7 nF	5.6 nF	15 nF	1.8 nF	3.9 nF	10 nF	2.7 nF	5.6 nF	15 nF	3.3 nF	6.8 nF	18 nF	8.2 nF	15 nF	47 nF	040
	1.2 nF	2.2 nF	5.6 nF	2.7 nF	5.6 nF	15 nF	1.8 nF	3.9 nF	10 nF	2.7 nF	5.6 nF	15 nF	3.3 nF	6.8 nF	18 nF	8.2 nF	15 nF	47 nF	060
	2.2 nF	3.9 nF	18 nF	5.6 nF	10 nF	47 nF	3.9 nF	6.8 nF	33 nF	5.6 nF	10 nF	47 nF	6.8 nF	12 nF	56 nF	18 nF	33 nF	120 nF	100
	3.3 nF	6.8 nF	22 nF	8.2 nF	15 nF	56 nF	5.6 nF	10 nF	39 nF	8.2 nF	15 nF	56 nF	10 nF	18 nF	68 nF	27 nF	47 nF	180 nF	140
	4.7 nF	8.2 nF	27 nF	12 nF	22 nF	68 nF	8.2 nF	15 nF	47 nF	12 nF	22 nF	68 nF	12 nF	27 nF	82 nF	33 nF	68 nF	220 nF	180

This document is subject to change without notice.

STACKED CAPACITOR Vertical

NPO N2T X7R 25V-10KV



SRT
MICROCÉRAMIQUE
MLCC CAPACITORS

APPLICATIONS

- Switch Mode Power Capacitor
- DC/DC Converter

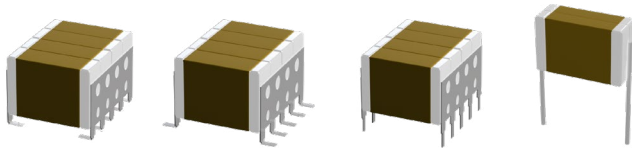

RoHS compliant

FEATURES

- Low ESR and ESL design
- Chips mounted vertically for better ESL
- 1210 MiniTurbocap with two Chips per row
- Available with 2 leads termination
- Competitors design equivalent

ELECTRICAL PARAMETERS

ELECTRICAL CHARACTERISTICS :
at + 25°C unless otherwise specified

OPERATING TEMPERATURE :
- 55°C, + 125°C

TEMPERATURE COEFFICIENT :
NPO : ± 30ppm
N2T : 2200 ± 350 ppm/°C
X7R : ± 15% with 0Vdc applied

DISSIPATION FACTOR:

NPO : ≤ 1.10⁻³ at 1Vrms and 1MHz for values ≤ 1000pF
 ≤ 1.10⁻³ at 1Vrms and 1KHz for values > 1000pF
 N2T : ≤ 1.10⁻³ at 1Vrms and 1MHz for values ≤ 1000pF
 ≤ 1.10⁻³ at 1Vrms and 1KHz for values > 1000pF
 X7R : ≤ 0.025 at 1kHz

INSULATION RESISTANCE (IR) :

25°C/Un 10⁵ MOhm or 1000 Ohm-Farad whichever is less
 125°C/Un 10⁴ MOhm or 100 Ohm-Farad whichever is less

DIELECTRIC STRENGTH TEST :

2.5U U≤200V | U+250V 200<U≤500 | 1.5U 500<U<1000 | 1.2U U≥1000
 for 5s with 50mA max charging current

BURN IN :

48 hours 125°C 2Un if Un<500V and 1.5 Un if Un >500V

ORDERING INFORMATION

SRTV	2225	Y	102	J	A	L	2	-	B	-
SERIES	SIZE	DIELECTRIC	CAPACITANCE	TOLERANCE	VOLTAGE	FORM	LEADS	COATING	PACKAGING	SPECIAL
SRTV	1210 1812 2220 2225 2825 3033 3640 4040 5550 6660 8060	A = NPO P = N2T Y = X7R X = BX BY = 2C1	Expressed in picofarads (pF), significant, the third digit give the number of noughts. Example : 102 = 1 000pF For special values R is used as decimal separator Example 12R7 = 12.7pF 1340R0 = 1340pF	A = ±0.05pF if < 10pF and 0.05% if > 10pF B = ± 0.1pF C = ± 0.25pF D = ± 0.5pF F = ± 1% G = ± 2% J = ± 5% K = ± 10% M = ± 20%	X = 25V A = 50V B = 100V C = 200V E = 500V F = 630V G = 1000V O = 1500V H = 2000V I = 3000V L = 5000V 10 = 10000V	J L D T = 2 leads	- 1 10	- I = Conformal Coating H = Epoxy Coating	B = Reel V = Bulk	- BM = BME Dxx = Reliability spec Exx = Sorting spec

For other sizes, voltage, tolerance contact us

DIMENSIONS (IN MILLIMETERS)

	1210	1812	2220	2225	3033	3640	4040	5440	5550	6560	6080	8060
Lenght (L)	3.80 ± 0.3	5.10 ± 0.4	6.20 ± 0.4	6.20 ± 0.4	8.20 ± 0.4	10.00 ± 0.4	10.80 ± 0.4	14.30 ± 0.4	14.60 ± 0.4	17.10 ± 0.4	15.80 ± 0.4	20.90 ± 0.4
Width(W) 1 Leads	5.20 ± 0.3											
Width(W) 2 Leads	5.20 ± 0.3	5.20 ± 0.4	5.20 ± 0.4	5.20 ± 0.4	5.20 ± 0.4	5.20 ± 0.4	5.20 ± 0.4	5.20 ± 0.4				
Width(W) 3 Leads	7.70 ± 0.3	7.70 ± 0.4	7.70 ± 0.4	7.70 ± 0.4	7.70 ± 0.4	7.70 ± 0.4	7.70 ± 0.4	7.70 ± 0.4	7.70 ± 0.4	7.70 ± 0.4		7.70 ± 0.4
Width(W) 4 Leads	10.30 ± 0.3	10.30 ± 0.4	10.30 ± 0.4	10.30 ± 0.4	10.30 ± 0.4	10.30 ± 0.4	10.30 ± 0.4	10.30 ± 0.4	10.30 ± 0.4	10.30 ± 0.4	10.30 ± 0.4	10.30 ± 0.4
Width(W) 5 Leads	12.80 ± 0.3	12.80 ± 0.4	12.80 ± 0.4	12.80 ± 0.4	12.80 ± 0.4	12.80 ± 0.4	12.80 ± 0.4	12.80 ± 0.4	12.80 ± 0.4	12.80 ± 0.4	12.80 ± 0.4	12.80 ± 0.4
Width(W) 6 Leads	15.30 ± 0.3	15.30 ± 0.4	15.30 ± 0.4	15.30 ± 0.4	15.30 ± 0.4	15.30 ± 0.4	15.30 ± 0.4	15.30 ± 0.4	15.30 ± 0.4	15.30 ± 0.4	15.30 ± 0.4	15.30 ± 0.4
Width(W) 7 Leads	17.90 ± 0.3	17.90 ± 0.4	17.90 ± 0.4	17.90 ± 0.4	17.90 ± 0.4	17.90 ± 0.4	17.90 ± 0.4	17.90 ± 0.4	17.90 ± 0.4	17.90 ± 0.4	17.90 ± 0.4	17.90 ± 0.4
Width(W) 8 Leads	20.40 ± 0.3	20.40 ± 0.4	20.40 ± 0.4	20.40 ± 0.4	20.40 ± 0.4	20.40 ± 0.4	20.40 ± 0.4	20.40 ± 0.4	20.40 ± 0.4	20.40 ± 0.4	20.40 ± 0.4	20.40 ± 0.4
Width(W) 9 Leads	23.00 ± 0.3	23.00 ± 0.4	23.00 ± 0.4	23.00 ± 0.4	23.00 ± 0.4	23.00 ± 0.4	23.00 ± 0.4	23.00 ± 0.4	23.00 ± 0.4	23.00 ± 0.4	23.00 ± 0.4	23.00 ± 0.4
Width(W) 10 Leads	25.50 ± 0.3	25.50 ± 0.4	25.50 ± 0.4	25.50 ± 0.4	25.50 ± 0.4	25.50 ± 0.4	25.50 ± 0.4	25.50 ± 0.4	25.50 ± 0.4	25.50 ± 0.4	25.50 ± 0.4	25.50 ± 0.4
Height (H)	5.30 ± 0.3	3.20 ± 0.4	5.10 ± 0.4	6.35 ± 0.4	8.40 ± 0.4	10.20 ± 0.4	10.20 ± 0.4	10.20 ± 0.4	12.70 ± 0.4	15.20 ± 0.4	20.30 ± 0.4	15.20 ± 0.4
Height (T)	6.60 ± 0.3	5.00 ± 0.4	6.90 ± 0.4	8.15 ± 0.4	10.20 ± 0.4	12.00 ± 0.4	12.00 ± 0.4	12.00 ± 0.4	14.50 ± 0.4	17.00 ± 0.4	22.10 ± 0.4	17.00 ± 0.4
Lead Height (C)	1.3 ± 0.3	1.8 ± 0.3	1.8 ± 0.3	1.8 ± 0.3	1.8 ± 0.3	1.8 ± 0.3	1.8 ± 0.3	1.8 ± 0.3	1.8 ± 0.3	1.8 ± 0.3	1.8 ± 0.3	1.8 ± 0.3
Lead Lenght (D)	1.3 ± 0.3	1.4 ± 0.3	1.6 ± 0.3	1.8 ± 0.3	1.8 ± 0.3	1.8 ± 0.3	1.8 ± 0.3	1.8 ± 0.3	1.8 ± 0.3	1.8 ± 0.3	1.8 ± 0.3	1.8 ± 0.3
Lead Height (E)	1.0 ± 0.3	1.3 ± 0.3	1.3 ± 0.3	1.3 ± 0.3	1.3 ± 0.3	1.3 ± 0.3	1.3 ± 0.3	1.3 ± 0.3	1.3 ± 0.3	1.3 ± 0.3	1.3 ± 0.3	1.3 ± 0.3
Lead Lenght (F)	4.0 ± 1.0	4.0 ± 1.0	4.5 ± 1.0	5.0 ± 1.0	6.0 ± 1.0	6.0 ± 1.0	6.0 ± 1.0	6.0 ± 1.0	6.0 ± 1.0	6.0 ± 1.0	6.0 ± 1.0	6.0 ± 1.0

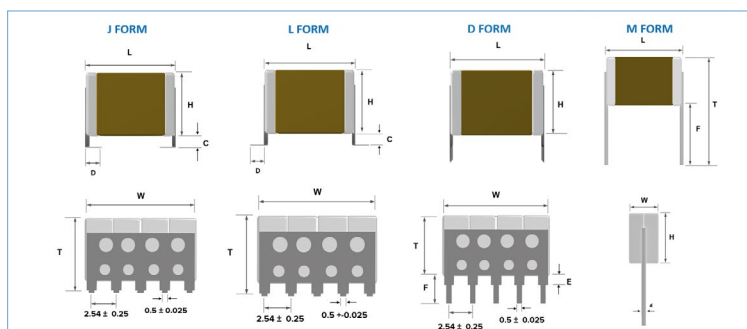

This document is subject to change without notice.

STACKED CAPACITOR High Compact

10V - 2000V



SRT
MICROCÉRAMIQUE
MLCC CAPACITORS

APPLICATIONS

- Smoothing signals
- Energy storage
- Converters, inverters

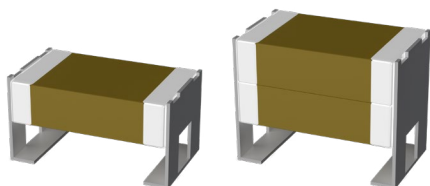

RoHS
compliant



FEATURES

- Low ESR and ESL design
- Auto range based on AECQ -200 generic requirement
- Extended range based on commercial grade
- High Reliability Copper Beryllium Lead Frame
- Available in Tin or SnPb Plating

ELECTRICAL PARAMETERS

ELECTRICAL CHARACTERISTICS :
at + 25°C unless otherwise specified

OPERATING TEMPERATURE :

NPO, X7R : - 55°C, + 125°C
X5R : - 55°C, + 85°C
Y5V : - 25°C, + 85°C

TEMPERATURE COEFFICIENT :

X7R : ± 15% with 0Vdc applied
X5R : ± 15% with 0Vdc applied
Y5V : +30% -80% with 0Vdc applied

DISSIPATION FACTOR :

NPO : ≤ 1.10⁻³ at 1Vrms and 1MHz for values ≤ 1000pF
 : ≤ 1.10⁻³ at 1Vrms and 1KHz for values > 1000pF
X7R : ≤ 5% (10V), ≤ 3.5% (16V and 25V) and ≤ 2.5% (50V to 2000V)
X5R : ≤ 15% (6.3V), ≤ 10% (16V, 25V, 35V)
Y5V : ≤ 12.5% (16V)

INSULATION RESISTANCE (IR) :

25°C/Un 10⁵ MOhm or 1000 Ohm-Farad whichever is less
125°C/Un 10⁴ MOhm or 100 Ohm-Farad whichever is less

DIELECTRIC STRENGTH TEST :

2.5U U≤200V | U+250V 200<U≤500 | 1.5U 500<U<1000 | 1.2U U≥1000
for 5s with 50mA max charging current

ORDERING INFORMATION

SRH	D	1210	Y	106	K	Q	-	A	B	-
SERIE	CHIPS	SIZE	DIELECTRIC	CAPACITANCE	TOLERANCE	VOLTAGE	LEAD FRAME	RANGE	PACKAGING	SPECIAL
SRH	S = 1 chip D = 2 chips	1210 1812 2220	A = NPO Y = X7R S = X5R V = Y5V	Expressed in picofarads (pF) The first two digits are significant, the third digit gives the number of noughts Example : 102 = 1 000pF	J = ± 5% (1 chip NPO) K = ± 10% (1 chip Class II/ 2 chips NPO) M = ± 20% (1 or 2 chips Class II)	Q = 10V J = 16 V X = 25 V A = 50 V U = 63 V B = 100 V P = 250 V E = 500 V F = 630 V G = 1000 V O = 1500 V H = 2000 V	- = Tin Plated N = SnPb Plated	A = AECQ E = Commercial	B = Reel	Dxx = Reliability parameters

For any other size, voltage and tolerance please contact us.

DIMENSIONS J (In millimeters)

1 CHIP STACK	1210	1812	2220
Length (L)	3.50 ± 0.30	5.00 ± 0.45	6.00 ± 0.50
Width (W)	2.60 ± 0.30	3.5 ± 0.50	5.00 ± 0.50
Max Height std (T)	3.35 ± 0.10	2.90 ± 0.10	3.50 ± 0.30
Max Height alt (T)			4.10 ± 0.30
Lead Width (D)	0.80 ± 0.15	1.10 ± 0.30	1.60 ± 0.30

2 CHIPS STACK	1210	1812	2220
Length (L)	3.50 ± 0.30	5.00 ± 0.45	6.00 ± 0.50
Width (W)	2.60 ± 0.30	3.5 ± 0.50	5.00 ± 0.50
Max Height std (T)	6.15 ± 0.15	5.00 ± 0.5	5.00 ± 0.50
Max Height alt (T)			7.20 ± 0.50
Lead Width (D)	0.80 ± 0.15	1.10 ± 0.30	1.60 ± 0.30

Refere to Value Chart for Height std or Height alt

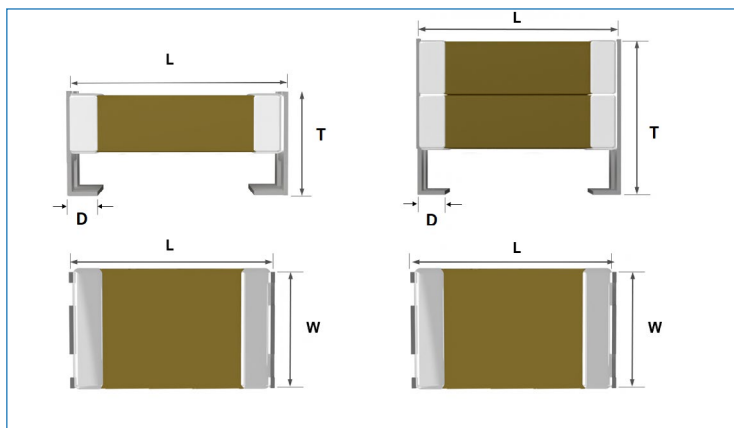

This document is subject to change without notice.

SIZE			1210				1812
DIELECTRIC			X5R				Y5V
Nb chip	CODE	CAP	6.3V	16V	25V	35V	16V
1 chip	106	10 µF				E	
	226	22 µF				E	
	476	47 µF			E		E
	107	100 µF		E			
	227	220 µF	E				
2 chips	226	22 µF				E	
	476	47 µF				E	
	107	100 µF			E		E
	227	220 µF		E			
	477	470 µF	E				

E : Commercial range

Contact us for any other voltage, capacitance value, tolerance...

AECQ QUALITY STANDARD

Our components are all subject so strict internal qualifications. For this series, our auto generic range is based on AECQ standards. This means that our chips will meet the quality requirements defined by the AEC.

The Auto generic range of our high compact series are designed to meet the Automotive industry standard, but will not require submitting a SCD (Source Controlled Drawing). This series is therefore not AEC qualified, and will not be primarily addressed to Automotive customers. These quality standards include specific tests, such as : Shear test, board flex, environmental tests, and these stacks insure good performance and reliability.

TYPICAL CHARACTERISTICS

Board Flex Breaking

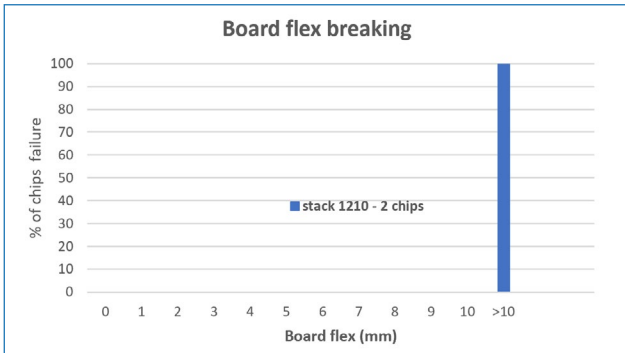

Shear test

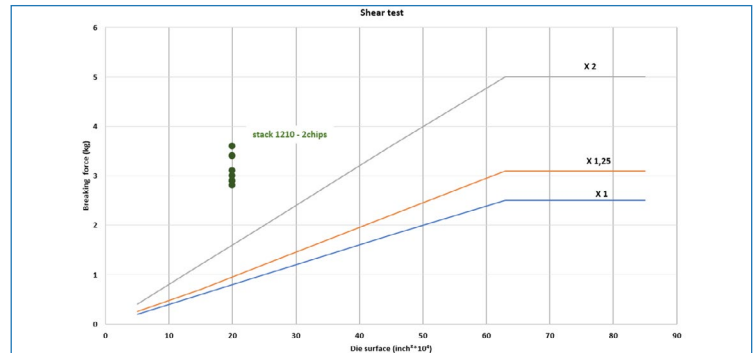

RADIAL CAPACITOR Dipped High Power

NPO N2T X7R 25V-1000V



SRT
MICROCÉRAMIQUE
MLCC CAPACITORS

APPLICATIONS

- Severe environment
- Historical design



FEATURES

- Highly reliable design
- Epoxy coating option
- Available in NPO, N2T, BX, 2X1, X7R
- Non magnetic option
- Equivalence to most competitors design (cf file)

ELECTRICAL PARAMETERS

ELECTRICAL CHARACTERISTICS :
at + 25°C unless otherwise specified

OPERATING TEMPERATURE :
- 55°C, + 125°C

TEMPERATURE COEFFICIENT :
NPO : ± 30 ppm
N2T : 2200 ± 350 ppm/C°
X7R : $\pm 15\%$ with 0Vdc applied

DISSIPATION FACTOR:
NPO : $\leq 1.10^{-3}$ at 1Vrms and 1MHz for values ≤ 1000 pF
 $\leq 1.10^{-3}$ at 1Vrms and 1KHz for values > 1000 pF
N2T : $\leq 1.10^{-3}$ at 1Vrms and 1MHz for values ≤ 1000 pF
 $\leq 1.10^{-3}$ at 1Vrms and 1KHz for values > 1000 pF
X7R : ≤ 0.025 at 1kHz

INSULATION RESISTANCE (IR) :
25°C/Un 10^5 MOhm or 1000 Ohm-Farad whichever is less
125°C/Un 10^4 MOhm or 100 Ohm-Farad whichever is less

Dielectric Strength Test :
2.5Un $U \leq 200V$ | $U + 250V$ $200 < U \leq 500$ | $1.5U$ $500 < U < 1000$ | $1.2U$ $U \geq 1000$
for 5s with 50mA max charging current

BURN IN :
48 hours 125°C 2Un if $U_n < 500V$ and $1.5 U_n$ if $U_n > 500V$

ORDERING INFORMATION

SRMC	41	Y	102	J	A	-	-	B	-	
SERIES	SIZE	DIELECTRIC	CAPACITANCE	TOLERANCE	VOLTAGE	TERMINATION	LEAD	COATING	PACKAGING	SPECIAL
SRMC	31 to 96	A = NPO P = N2T Y = X7R X = BX BY = 2C1	Expressed in picofarads (pF). The first two digits are significant, the third digit give the number of noughts. Example : 102 = 1 000pF For special values R is used as decimal separator Example 12R7 = 12.7pF 1340R0 = 1340pF	A = ± 0.05 pF if < 10 pF and 0.05% if > 10 pF B = ± 0.1 pF C = ± 0.25 pF D = ± 0.5 pF F = $\pm 1\%$ G = $\pm 2\%$ J = $\pm 5\%$ K = $\pm 10\%$ M = $\pm 20\%$	X = 25V A = 50V B = 100V C = 200V E = 500V G = 1000V	- = Sn C = Non magnetic	- = Default A,C,D Form B = B Form	- = Conformal Coating H = Epoxy Coating	V = Bulk	- BM = BME Dxx = Reliability spec Exx = Sorting spec

For other sizes, voltage, tolerance contact us

DIMENSIONS (in millimeters)

SIZE	31	32	38	40	41	43	44	45	47	48	49	52	54	58
Lenght (L) max	3.8	5.0	6.4	3.8	5.1	6.5	7.6	10.1	8.1	5.1	9.4	6.6	9.0	11.9
Height (W) max	3.8	5.0	5.6	3.8	5.1	5.8	7.0	10.2	7.1	3.8	7.6	5.6	7.5	10.2
Width (H) max	2.5	3.2	5.0	2.5	3.2	3.8	4.5	4.5	5.0	4.0	5.0	4.0	4.0	5.0
Lead spacing (LS) $\pm 0,5$	2.54	2.54	4.30	5.08	5.08	5.08	5.08	5.08	5.60	6.40	7.00	7.62	7.62	9.50
Lead diameter (D)	0.6	0.6	0.6	0.6	0.6	0.6	0.6	0.6	0.6	0.6	0.6	0.6	0.6	0.6
Lead type	C	C	C	D	A/B	C	C	C	C	D	C	D	C	C
SIZE	60	63	68	72	74	76	80	82	84	88	90	91	92	96
Lenght (L) max	10.0	12.7	14.5	12.0	17.0	16.0	18.7	19.6	18.5	22.1	25.0	26.7	30.0	42.5
Height (W) max	10.0	12.3	12.7	12.5	14.0	12.5	22.5	18.3	17.5	16.8	19.0	12.7	22.5	20.0
Width (H) max	5.0	5.0	5.0	5.0	5.0	5.0	5.0	5.0	5.0	5.0	5.0	5.0	5.0	5.0
Lead spacing (LS) $\pm 0,5$	10.16	10.16	12.00	12.70	14.60	15.24	15.24	17.10	17.80	20.30	21.00	22.90	27.94	40.64
Lead diameter (D)	0.6	0.6	0.6	0.6	0.6	0.8	0.8	0.8	0.8	0.8	0.8	0.8	0.8	1.0
Lead type	A/B	C	C	A/B	C	A/B	C	C	A/B	A/B	C	C	A/B	A/B

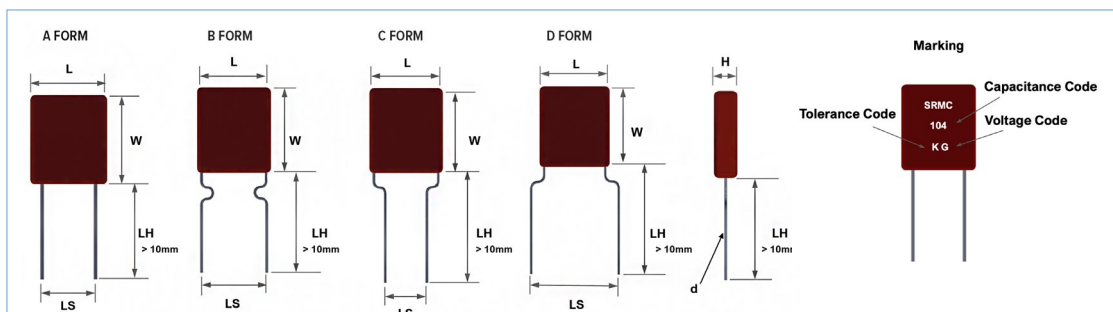

This document is subject to change without notice.

RADIAL CAPACITOR Dipped High Voltage

NPO N2T X7R 1KV-15KV



SRT
MICROCÉRAMIQUE
MLCC CAPACITORS

APPLICATIONS

- Severe environment
- Historical design



FEATURES

- Highly reliable design
- Epoxy coating option
- Available in NPO, N2T, BX, 2X1, X7R
- Non magnetic option
- Equivalence to most concurrent design (cf file)
- Marking of larger components

ELECTRICAL PARAMETERS

ELECTRICAL CHARACTERISTICS :
at + 25°C unless otherwise specified

OPERATING TEMPERATURE :
- 55°C, + 125°C

TEMPERATURE COEFFICIENT :
NPO : ± 30ppm
N2T : 2200 ± 350 ppm/°C
X7R : ± 15% with 0Vdc applied

DISSIPATION FACTOR:
NPO : ≤ 1.10⁻³ at 1Vrms and 1MHz for values ≤ 1000pF
 ≤ 1.10⁻³ at 1Vrms and 1KHz for values > 1000pF
N2T : ≤ 1.10⁻³ at 1Vrms and 1MHz for values ≤ 1000pF
 ≤ 1.10⁻³ at 1Vrms and 1KHz for values > 1000pF
X7R : ≤ 0.025 at 1kHz
2C1, BX : Q2,5% max

INSULATION RESISTANCE (IR) :
25°C/Un 10⁵ MOhm or 1000 Ohm-Farad whichever is less
125°C/Un 10⁴ MOhm or 100 Ohm-Farad whichever is less

DIELECTRIC STRENGTH TEST :
1.2Un for 5s with 50mA max charging current

BURN IN :
48 hours 125°C 2Un if Un<500V and 1.5 Un if Un >500V

ORDERING INFORMATION

SRMC	41	Y	104	K	G	-	-	E	B	-
SERIES	SIZE	DIELECTRIC	CAPACITANCE	TOLERANCE	VOLTAGE	TERMINATION	LEAD	COATING	PACKAGING	SPECIAL
SRMC	31 to 96	A = NPO P = N2T X = BX Y=X7R BY=2C1	Expressed in picofarads (pF). The first two digits are significant, the third digit give the number of noughts. Example : 102 = 1 000pF For special values R is used as decimal separator Example 12R7 = 12.7pF 1340R0 = 1340pF	A = ±0.05pF if < 10pF and 0.05% if > 10pF B = ± 0.1pF C = ± 0.25pF D = ± 0.5pF F = ± 1% G = ± 2% J = ± 5% K = ± 10% M = ± 20%	G = 1000V O = 1500V H = 2000V I = 3000V L = 5000V 6 = 6000V 8 = 8000V 10 = 10kV 12 = 12kV 15 = 15kV	- = Sn C = Non magnetic	- = Default A,C,D Form B = B Form	- = Conformal Coating H = Epoxy Coating	V = Bulk	- BM = BME Dxx = Reliability spec Exx = Sorting spec

For other sizes, voltage, tolerance contact us

DIMENSIONS (in millimeters)

SIZE	31	32	38	40	41	43	44	45	47	48	49	52	54	58	59
Lenght (L) max	3.8	5.0	6.4	3.8	5.1	6.5	7.6	10.1	8.1	5.1	9.4	6.6	9.0	11.9	6.5
Height (W) max	3.8	5.0	5.6	3.8	5.1	5.8	7.0	10.2	7.1	3.8	7.6	5.6	7.5	10.2	5.8
Width (H) max	2.5	3.2	5.0	2.5	3.2	3.8	4.5	4.5	5.0	4.0	5.0	4.0	4.0	5.0	3.8
Lead spacing (LS) ± 0,5	2.54	2.54	4.30	5.08	5.08	5.08	5.08	5.08	5.60	6.40	7.00	7.62	7.62	9.50	10.16
Lead diameter (d)	0.6	0.6	0.6	0.6	0.6	0.6	0.6	0.6	0.6	0.6	0.6	0.6	0.6	0.6	0.6
Lead type	C	C	C	D	A/B	C	C	C	C	D	C	D	C	C	D

SIZE	60	63	68	72	74	76	80	81	82	83	84	88	90	91	92
Lenght (L) max	10.0	12.7	14.5	12.0	17.0	16.0	18.7	25.0	19.6	21.6	18.5	22.1	25.0	26.7	30.0
Height (W) max	10.0	12.3	12.7	12.5	14.0	12.5	22.5	19.0	18.3	10.2	17.5	16.8	19.0	12.7	22.5
Width (H) max	5.0	5.0	5.0	5.0	5.0	5.0	5.0	5.0	5.0	6.9	5.0	5.0	5.0	5.0	5.0
Lead spacing (LS) ± 0,5	10.16	10.16	12.00	12.70	14.60	15.24	15.24	15.24	17.10	17.80	17.80	20.30	21.00	22.90	27.94
Lead diameter (d)	0.6	0.6	0.6	0.6	0.6	0.8	0.8	0.8	0.8	0.6	0.8	0.8	0.8	0.8	0.8
Lead type	A/B	C	C	A/B	C	A/B	C	C	C	C	A/B	A/B	C	C	A/B

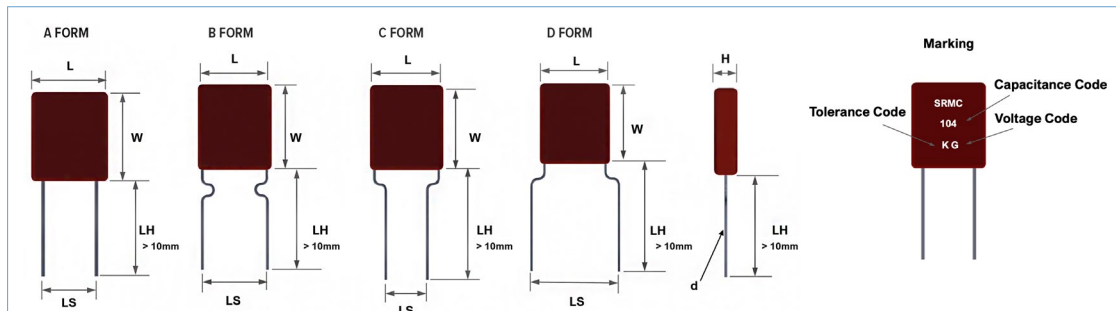

This document is subject to change without notice.

RADIAL CAPACITOR Encapsulated

NPO N2T X7R 25V-15KV



SRT
MICROCÉRAMIQUE
MLCC CAPACITORS

APPLICATIONS

- Severe environment
- Historical design

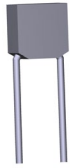

RoHS
compliant

FEATURES

- Leded radial MLCC capacitor
- Epoxy molded
- High reliability, 100% burn in
- Available in NPO, N2T, BX, 2X1, X7R
- Equivalent to wide range of competitors design
- Custom voltage, package size, capacitance value on request
- Tested in accordance to CECC 32100 and AEC-Q200
- NPO version CECC 30600 et NFC 83-131 compliant
- X7R version CECC 30700 et NFC 83-132 compliant
- 2C1 version NF 83-132 compliant
- High Reliability option : 168 hours burn in
- Laser marked

ELECTRICAL PARAMETERS

ELECTRICAL CHARACTERISTICS :
at + 25°C unless otherwise specified

OPERATING TEMPERATURE :

X7R, N2T : - 55°C, + 125°C
NPO : - 55°C, + 125°C

TEMPERATURE COEFFICIENT :

NPO : ± 30ppm
N2T : -2200 ± 350 ppm/°C
X7R : ± 15% with 0Vdc applied

DISSIPATION FACTOR:

NPO : ≤ 1.10⁻³ at 1Vrms and 1MHz for values ≤ 1000pF
≤ 1.10⁻³ at 1Vrms and 1KHz for values > 1000pF
N2T : ≤ 1.10⁻³ at 1Vrms and 1MHz for values ≤ 1000pF
≤ 1.10⁻³ at 1Vrms and 1KHz for values > 1000pF
X7R : ≤ 0.025 at 1kHz

INSULATION RESISTANCE (IR) :

25°C/Un 10⁵ MOhm or 1000 Ohm-Farad whichever is less
125°C/Un 10⁴ MOhm or 100 Ohm-Farad whichever is less

DIELECTRIC STRENGTH TEST :

2.5U U≤200V | U+250V 200<U≤500 | 1.5U 500<U<1000 | 1.2U U≥1000
for 5s with 50mA max charging current

BURN IN :

48 hours 125°C 2U U≤500 | 1.5U 500<U<1000 | 1.2U U≥1000

ORDERING INFORMATION

SR	41	Y	102	J	A	-	V	XX
SERIES	SIZE	DIELECTRIC	CAPACITANCE	TOLERANCE	VOLTAGE	TERMINATION	PACKAGING	SPECIAL
SR	41 to 94	A = NPO P = N2T X = BX Y = X7R BY=2C1	Expressed in picofarads (pF). The first two digits are significant, the third digit give the number of noughts. Example : 102 = 1 000pF For special values R is used as decimal separator Example 12R7 = 12.7pF 1340R0 = 1340pF	A = ±0.05pF if < 10pF and 0.05% if > 10pF B = ± 0.1pF C = ± 0,25pF D = ± 0,5pF F = ± 1% G = ± 2% J = ± 5% K = ± 10% M = ± 20%	X = 25 V A = 50 V U = 63 V B = 100 V C = 200 V P = 250 V E = 500 V F = 630 V G = 1 KV H = 2 KV I = 3 KV K = 4 KV L = 5 KV 6 = 6 KV 8 = 8 KV 10 = 10 KV 15 = 15 KV	- : Sn C = Non magnetic	V = Bulk	- BM = BME Dxx = Reliability spec Exx = Sorting spec

For other sizes, voltage, tolerance contact us

DIMENSIONS (in millimeters)

SIZE	SR41	SR43	SR45	SR47	SR50	SR60	SR64	SR65
Lenght (L) max	4.0	5.0	7.5	4.0	5.0	7.5	10.0	10.5
Height (W) max	4.5	5.0	7.5	4.5	5.0	7.5	11.0	9.0
Width (T) max	2.5	2.5	2.5	2.5	2.5	2.5	3.5	6.5
Lead spacing (LS) ± 0,5	2.54	2.54	4.32	5.08	5.08	5.08	5.08	7.62
Lead diameter (D)	0.6	0.6	0.6	0.6	0.6	0.6	0.8	0.8

SIZE	SR68	SR70	SR74	SR78	SR82	SR86	SR90	SR94
Lenght (L) max	13.0	13.0	18.4	18.0	20.0	28.5	31.0	45.0
Height (W) max	12.0	12.0	12.7	16.0	19.0	19.0	24.0	23.0
Width (T) max	3.5	6.5	8.0	8.0	8.0	8.0	8.0	8.0
Lead spacing (LS) ± 0,5	10.16	10.16	12.20	15.20	17.30	19.80	27.90	40.60
Lead diameter (D)	0.8	0.8	0.8	0.8	0.8	0.8	1.0	1.0

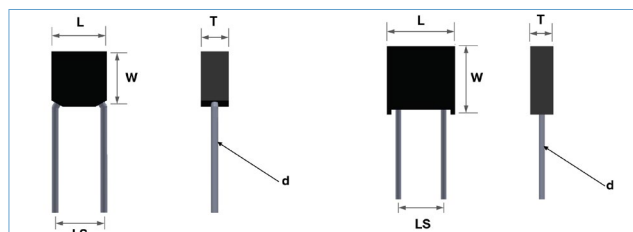

This document is subject to change without notice.

RADIAL CAPACITOR Encapsulated

NPO N2T X7R 25V-15KV



SRT
MICROCÉRAMIQUE
MLCC CAPACITORS

QUICK REFERENCE DATA (Max capacitance)

	SR41			SR43			SR45			SR47		
	NPO	N2T	X7R	NPO	N2T	X7R	NPO	N2T	X7R	NPO	N2T	X7R
Min	<i>=Datas Radi-</i>	0.3 pF	2.2 pF	0.4 pF	4.7 pF	10 pF	1.0 pF	10 pF	33 pF	0.1 pF	0.3 pF	2.2 pF
25V	<i>15 nF</i>	5.6 nF	39 nF	<i>220 nF</i>	56 nF	390 nF	<i>470 nF</i>	270 nF	2.2 μF	<i>15 nF</i>	5.6 nF	39 nF
50V	<i>10 nF</i>	5.6 nF	39 nF	<i>150 nF</i>	56 nF	390 nF	<i>470 nF</i>	270 nF	2.2 μF	<i>10 nF</i>	5.6 nF	39 nF
100V	<i>10 nF</i>	5.6 nF	39 nF	<i>100 nF</i>	56 nF	390 nF	<i>330 nF</i>	270 nF	2.2 μF	<i>10 nF</i>	5.6 nF	39 nF
200V	<i>2.2 nF</i>	4.7 nF	33 nF	<i>47 nF</i>	56 nF	390 nF	<i>220 nF</i>	270 nF	2.2 μF	<i>2.2 nF</i>	4.7 nF	33 nF
500V	560 pF	1.8 nF	4.7 nF	10 nF	33 nF	100 nF	56 nF	150 nF	470 nF	560 pF	1.8 nF	4.7 nF
630V	330 pF	1.0 nF	2.7 nF	6.8 nF	18 nF	56 nF	33 nF	100 nF	270 nF	330 pF	1.0 nF	2.7 nF
1000V	120 pF	390 pF	820 pF	2.7 nF	8.2 nF	15 nF	12 nF	39 nF	82 nF	120 pF	390 pF	820 pF
2000V				390 pF	1.2 nF	2.7 nF	2.2 nF	6.8 nF	18 nF			

	SR50			SR60			SR64			SR65		
	NPO	N2T	X7R	NPO	N2T	X7R	NPO	N2T	X7R	NPO	N2T	X7R
Min	220 nF	68 nF	390 nF	470 nF	330 nF	1.8 μF	120 nF	470 nF	2.7 μF	150 nF	680 nF	3.9 μF
25V	<i>150 nF</i>	68 nF	390 nF	<i>470 nF</i>	330 nF	1.8 μF	120 nF	470 nF	2.7 μF	150 nF	680 nF	3.9 μF
50V	<i>100 nF</i>	68 nF	390 nF	<i>330 nF</i>	330 nF	1.8 μF	120 nF	470 nF	2.7 μF	150 nF	680 nF	3.9 μF
100V	<i>47 nF</i>	68 nF	390 nF	<i>220 nF</i>	330 nF	1.8 μF	120 nF	470 nF	2.7 μF	150 nF	680 nF	3.9 μF
200V	<i>15 nF</i>	33 nF	120 nF	<i>68 nF</i>	150 nF	560 nF	120 nF	270 nF	1.2 μF	150 nF	390 nF	1.8 μF
500V	12 nF	22 nF	68 nF	47 nF	100 nF	330 nF	82 nF	220 nF	1.0 μF	120 nF	330 nF	1.2 μF
630V	3.9 nF	8.2 nF	22 nF	18 nF	39 nF	120 nF	56 nF	150 nF	560 nF	82 nF	220 nF	820 nF
1000V	820 pF	1.2 nF	3.9 nF	3.3 nF	6.8 nF	22 nF	18 nF	27 nF	120 nF	27 nF	39 nF	180 nF
2000V	270 pF	470 pF	1.5 nF	1.2 nF	2.7 nF	8.2 nF	4.7 nF	12 nF	39 nF	6.8 nF	15 nF	56 nF
3000V	120 pF	180 pF	820 pF	680 pF	1.2 nF	4.7 nF	3.3 nF	6.8 nF	27 nF	4.7 nF	10 nF	39 nF
4000V				390 pF	820 pF	2.7 nF	2.2 nF	3.9 nF	15 nF	3.3 nF	5.6 nF	22 nF
5000V				120 pF	220 pF	680 pF	680 pF	1.5 nF	4.7 nF	1.0 nF	2.2 nF	6.8 nF
8000V				68 pF	150 pF	390 pF	470 pF	820 pF	2.2 nF	680 pF	1.2 nF	3.3 nF
10KV										470 pF	820 pF	2.2 nF
12KV										270 pF	560 pF	1.8 nF

	SR68			SR70			SR74			SR78		
	NPO	N2T	X7R	NPO	N2T	X7R	NPO	N2T	X7R	NPO	N2T	X7R
Min	10 pF	47 pF	100 pF	10 pF	47 pF	100 pF	10 pF	33 pF	100 pF	10 pF	47 pF	100 pF
100V	220 nF	820 nF	5.6 μF	270 nF	1.0 μF	5.6 μF	270 nF	1.0 μF	6.8 μF	330 nF	1.2 μF	8.2 μF
200V	220 nF	820 nF	5.6 μF	270 nF	1.0 μF	5.6 μF	270 nF	1.0 μF	6.8 μF	330 nF	1.2 μF	8.2 μF
500V	220 nF	560 nF	2.7 μF	270 nF	680 nF	2.7 μF	270 nF	820 nF	3.3 μF	330 nF	1.0 μF	3.9 μF
630V	180 nF	470 nF	1.8 μF	220 nF	560 nF	2.2 μF	220 nF	560 nF	2.7 μF	270 nF	680 nF	2.7 μF
1KV	120 nF	330 nF	1.2 μF	120 nF	330 nF	1.2 μF	150 nF	390 nF	1.5 μF	180 nF	470 nF	1.8 μF
2KV	39 nF	56 nF	270 nF	47 nF	56 nF	270 nF	47 nF	68 nF	330 nF	56 nF	82 nF	390 nF
3KV	10 nF	22 nF	82 nF	12 nF	27 nF	100 nF	12 nF	27 nF	120 nF	15 nF	33 nF	120 nF
4KV	6.8 nF	15 nF	56 nF	8.2 nF	15 nF	56 nF	8.2 nF	18 nF	68 nF	10 nF	22 nF	82 nF
5KV	4.7 nF	8.2 nF	33 nF	5.6 nF	10 nF	33 nF	5.6 nF	10 nF	39 nF	6.8 nF	12 nF	47 nF
6KV	2.7 nF	5.6 nF	18 nF	2.7 nF	5.6 nF	22 nF	3.3 nF	6.8 nF	22 nF	3.9 nF	8.2 nF	27 nF
8KV	1.2 nF	3.3 nF	10 nF	1.5 nF	3.3 nF	12 nF	1.8 nF	3.9 nF	12 nF	2.2 nF	4.7 nF	15 nF
10KV	1.0 nF	1.8 nF	4.7 nF	1.0 nF	1.8 nF	5.6 nF	1.2 nF	2.2 nF	5.6 nF	1.5 nF	2.7 nF	6.8 nF
12KV	680 pF	1.2 nF	3.3 nF	680 pF	1.2 nF	3.9 nF	820 pF	1.5 nF	4.7 nF	1.0 nF	1.8 nF	5.6 nF
15KV	390 pF	680 pF		470 pF	820 pF		470 pF	820 pF		560 pF	1.0 nF	

	SR82			SR86			SR90			SR94		
	NPO	N2T	X7R	NPO	N2T	X7R	NPO	N2T	X7R	NPO	N2T	X7R
Min	10 pF	33 pF	100 pF	10 pF	47 pF	100 pF	22 pF	68 pF	180 pF	22 pF	68 pF	180 pF
100V	560 nF	2.2 μF	12 μF	560 nF	2.2 μF	15 μF	820 nF	3.3 μF	18 μF	1.0 μF	3.9 μF	27 μF
200V	560 nF	2.2 μF	12 μF	560 nF	2.2 μF	15 μF	820 nF	3.3 μF	18 μF	1.0 μF	3.9 μF	27 μF
500V	560 nF	1.8 μF	6.8 μF	560 nF	2.2 μF	8.2 μF	820 nF	2.7 μF	12 μF	1.0 μF	3.9 μF	18 μF
630V	470 nF	1.2 μF	5.6 μF	560 nF	1.5 μF	6.8 μF	820 nF	2.2 μF	8.2 μF	1.0 μF	3.3 μF	12 μF
1KV	330 nF	820 nF	3.3 μF	390 nF	1.0 μF	3.9 μF	560 nF	1.5 μF	5.6 μF	820 nF	2.2 μF	8.2 μF
2KV	100 nF	150 nF	680 nF	120 nF	180 nF	820 nF	180 nF	220 nF	1.2 μF	270 nF	390 nF	1.8 μF
3KV	27 nF	68 nF	220 nF	33 nF	82 nF	270 nF	47 nF	100 nF	390 nF	68 nF	150 nF	560 nF
4KV	18 nF	39 nF	150 nF	22 nF	47 nF	180 nF	33 nF	68 nF	220 nF	47 nF	100 nF	330 nF
5KV	12 nF	22 nF	82 nF	15 nF	27 nF	100 nF	22 nF	39 nF	150 nF	33 nF	56 nF	220 nF
6KV	6.8 nF	15 nF	56 nF	8.2 nF	18 nF	68 nF	12 nF	27 nF	82 nF	18 nF	39 nF	120 nF
8KV	3.9 nF	8.2 nF	27 nF	4.7 nF	10 nF	33 nF	5.6 nF	15 nF	47 nF	8.2 nF	22 nF	68 nF
10KV	2.7 nF	4.7 nF	12 nF	3.3 nF	5.6 nF	15 nF	4.7 nF	8.2 nF	22 nF	6.8 nF	12 nF	33 nF
12KV	1.8 nF	3.3 nF	10 nF	2.2 nF	3.9 nF	12 nF	2.7 nF	5.6 nF	15 nF	4.7 nF	8.2 nF	22 nF
15KV	1.0 nF	1.8 nF		1.2 nF	2.2 nF		1.8 nF	3.3 nF		2.7 nF	4.7 nF	

1) Max Values in italic obtained with BME part

This document is subject to change without notice.

AXIAL CAPACITOR Encapsulated

NPO N2T X7R 25V-5KV



SRT
MICROCÉRAMIQUE
MLCC CAPACITORS

APPLICATIONS

- Severe environment
- Historical design



FEATURES

- Leaded radial MLCC capacitor
- Epoxy molded
- High reliability, 100% burn in
- Available in NPO, N2T, BX, 2X1, X7R
- Equivalent to wide range of competitors design
- Custom voltage, package size, capacitance value on request
- Tested in accordance to CECC 32100 and AEC-Q200
- NPO version CECC 30600 et NFC 83-131 compliant
- X7R version CECC 30700 et NFC 83-132 compliant
- 2C1 version NF 83-132 compliant
- High Reliability option : 168 hours burn in

ELECTRICAL PARAMETERS

ELECTRICAL CHARACTERISTICS :
at + 25°C unless otherwise specified

OPERATING TEMPERATURE :
X7R, N2T : - 55°C, + 125°C
NPO : - 55°C, + 125°C

TEMPERATURE COEFFICIENT :
NPO : ± 30ppm
N2T : -2200 ± 350 ppm/°C
X7R : ± 15% with 0Vdc applied

DISSIPATION FACTOR:
NPO : ≤ 1.10⁻³ at 1Vrms and 1MHz for values ≤ 1000pF
≤ 1.10⁻³ at 1Vrms and 1KHz for values > 1000pF
N2T : ≤ 1.10⁻³ at 1Vrms and 1MHz for values ≤ 1000pF
≤ 1.10⁻³ at 1Vrms and 1KHz for values > 1000pF
X7R : ≤ 0.025 at 1kHz

INSULATION RESISTANCE (IR) :
25°C/Un 10⁵ MOhm or 1000 Ohm-Farad whichever is less
125°C/Un 10⁴ MOhm or 100 Ohm-Farad whichever is less

DIELECTRIC STRENGTH TEST :
2.5U U≤200V | U+250V 200<U≤500 | 1.5U 500<U<1000 | 1.2U U≥1000
for 5s with 50mA max charging current

BURN IN :
48 hours 125°C 2U U≤500 | 1.5U 500<U<1000 | 1.2U U≥1000

ORDERING INFORMATION

SA	70	Y	102	J	A	V	-
SERIES	SIZE	DIELECTRIC	CAPACITANCE	TOLERANCE	VOLTAGE	PACKAGING	SPECIAL
SA	40 50 60 70 80	A = NPO P = N2T X = BX Y = X7R BY=2C1	Expressed in picofarads (pF). The first two digits are significant, the third digit give the number of noughts. Example : 102 = 1 000pF For special values R is used as decimal separator Example 12R7 = 12.7pF 1340R0 = 1340pF	A = ±0.05pF if < 10pF and 0.05% if > 10pF B = ± 0,1pF C = ± 0,25pF D = ± 0,5pF F = ± 1% G = ± 2% J = ± 5% K = ± 10% M = ± 20%	X = 25 V A = 50 V U = 63 V B = 100 V C = 200 V P = 250 V E = 500 V F = 630 V G = 1 KV H = 2 KV I = 3 KV K = 4 KV L = 5 KV	V = Bulk	- Dxx = Reliability spec Exx = Sorting spec

For other sizes, voltage, tolerance contact us

DIMENSIONS (in millimeters)

SIZE	SA40	SA50	SA60	SA70	SA75	SA80	SA90
Lenght (L) ± 0.4	4,3	6,4	6,6	10	11	12,7	17,5
Diameter (D) ± 0.4	2,5	2,5	3,9	3,9	5,5	6,4	8,9
Lead diameter (D)	0,5	0,5	0,6	0,6	0,6	0,6	0,6
Lead minimal lenght	38	38	38	38	38	38	38

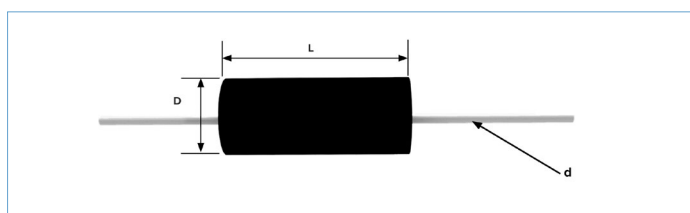

This document is subject to change without notice.

AXIAL CAPACITOR Encapsulated

NPO N2T X7R 25V-5KV



SRT
MICROCÉRAMIQUE
MLCC CAPACITORS

QUICK REFERENCE DATA (Max capacitance)

	SA40			SA50			SA60			SA70		
	NPO	N2T	X7R	NPO	N2T	X7R	NPO	N2T	X7R	NPO	N2T	X7R
Min	0.1 pF	0.3 pF	2.2 pF	0.1 pF	1.0 pF	6.8 pF	0.4 pF	4.7 pF	10 pF	1.0 pF	4.7 pF	10 pF
25V	<i>15 nF</i>	5.8 nF	<i>1.0 μF</i>	47 nF	15 nF	<i>4.7 μF</i>	<i>220 nF</i>	65 nF	<i>22 μF</i>	<i>220 nF</i>	140 nF	<i>22 μF</i>
50V	<i>10 nF</i>	5.7 nF	<i>470 nF</i>	33 nF	15 nF	<i>4.7 μF</i>	<i>150 nF</i>	65 nF	<i>10 μF</i>	<i>220 nF</i>	140 nF	<i>6.8 μF</i>
100V	<i>10 nF</i>	5.6 nF	<i>100 nF</i>	33 nF	15 nF	<i>1.0 μF</i>	<i>100 nF</i>	65 nF	<i>4.7 μF</i>	<i>150 nF</i>	140 nF	<i>4.7 μF</i>
200V	<i>2.2 nF</i>	5.5 nF	38 nF	10 nF	15 nF	100 nF	<i>47 nF</i>	65 nF	450 nF	<i>100 nF</i>	140 nF	970 nF
250V	<i>2.2 nF</i>	5.3 nF	29 nF	10 nF	15 nF	96 nF	<i>22 nF</i>	65 nF	400 nF	36 nF	140 nF	860 nF
500V	630 pF	1.8 nF	5.5 nF	2.5 nF	7.6 nF	22 nF	12 nF	39 nF	160 nF	26 nF	85 nF	350 nF
630V	380 pF	1.1 nF	2.9 nF	1.5 nF	4.6 nF	12 nF	9.6 nF	31 nF	100 nF	20 nF	67 nF	260 nF
1000V	140 pF	420 pF	850 pF	600 pF	1.8 nF	3.7 nF	5.0 nF	14 nF	32 nF	13 nF	42 nF	93 nF
1500V	58 pF	110 pF	270 pF	250 pF	520 pF	1.3 nF	2.1 nF	4.2 nF	11 nF	6.5 nF	12 nF	33 nF
2000V				97 pF	280 pF	590 pF	850 pF	2.5 nF	6.0 nF	1.9 nF	6.1 nF	16 nF

	SA75			SA80			SA90		
	NPO	N2T	X7R	NPO	N2T	X7R	NPO	N2T	X7R
Min	1.0 pF	4.7 pF	10 pF	1.0 pF	10 pF	33 pF	1.0 pF	10 pF	33 pF
25V	<i>220 nF</i>	140 nF	<i>22 μF</i>	<i>470 nF</i>	320 nF	22 μF	97 nF	370 nF	2.6 μF
50V	<i>220 nF</i>	140 nF	<i>6.8 μF</i>	<i>470 nF</i>	320 nF	10 μF	97 nF	370 nF	2.6 μF
100V	<i>150 nF</i>	140 nF	<i>4.7 μF</i>	<i>330 nF</i>	320 nF	10 μF	97 nF	370 nF	2.6 μF
200V	<i>100 nF</i>	140 nF	970 nF	<i>220 nF</i>	320 nF	2.2 μF	97 nF	370 nF	2.6 μF
250V	36 nF	140 nF	860 nF	84 nF	320 nF	2.0 μF	97 nF	370 nF	2.3 μF
500V	26 nF	85 nF	350 nF	60 nF	190 nF	830 nF	70 nF	220 nF	950 nF
630V	20 nF	67 nF	260 nF	48 nF	150 nF	600 nF	55 nF	180 nF	690 nF
1000V	13 nF	42 nF	93 nF	30 nF	99 nF	270 nF	35 nF	110 nF	310 nF
1500V	6.5 nF	12 nF	33 nF	18 nF	36 nF	88 nF	21 nF	42 nF	100 nF
2000V	1.9 nF	6.1 nF	16 nF	4.8 nF	15 nF	51 nF	5.7 nF	18 nF	61 nF

1) Max Values in italic obtained with BME part

This document is subject to change without notice.

APPLICATIONS

- If good electronic design dictates whenever it is possible to use standard components with multiple sources, some special needs can be only addressed with a custom developed product, as to allow gain in performance, compacity, reliability.
- With our highly flexible production, our offer in standard products covers a wide range of products, always without obsolescence.
- In addition to this standard range, designer can work with SRT-Microcéramique engineers to develop any combination of ceramic, voltage, capacity, package, reliability program to fit their exact needs.

OBSOLESCENCE

- The need to produce and maintain some electronic design for tens of years, often collides with the obsolescence policies of the major manufacturers. SRT-Microcéramique can provide strict equivalents to competitors designs, SMD, Stacks, Dipped, Encapsulated radials, axials... and insure its production overtime with its no obsolescence policy.

FORMAT

- For cross references needs or specific designs we can propose any SMD format between 0402 and 80300.
- Barcap, 4 corners, discs, arrays... can be proposed

CERAMIC

- In addition to its wide range of ceramic, type 1, type 2, N2T for power and pulse application, SRT-Microcéramique can also offer positive temperature coefficients, high temperature type 1 etc...

VOLTAGE

- Any specific voltage that is not in our standard range can be added (1100V, 1200V etc...) in order to optimize the component design.
- Very high voltage design up to 32KV.

CAPACITY

- Specific capacitance values that are not in the standard ISO range can be proposed.
- The codification of the specific P/N is based on the capacitance in picofarad with R as a decimal separator
- ex : 45,3pf = 45R3, 8320pf = 8320R0, 12.2nF = 12200R0

TERMINATION

- Any combination of components and termination, even if not present in our standard catalog can be proposed.
- Change of termination on any component, even if not produced by SRT, especially high value BME products is possible : Gold termination, dipped lead, dipped SAC, Silver-Palladium etc...

PACKAGE

- Any combination of stacks, leaded, dipped, encapsulated in any specific format can be proposed with PME SRT components or qualified BME high capacitance components.

SORTING

- SRT-Microcéramique, proposes on a regular basis, very high precision sorting for some of its customers.
- Up to 0.05% in Type 1, on specific value or cells.

RELIABILITY

- Depending on the Reliability need of the component, specific qualifications and testing programs can be agreed upon in addition to our standard process.
- Burn-In, LAT, RCS etc...
- SRT-Microcéramique regularly works with space, medical and defense customers.

DESIGN PROCESS

- Working directly with our engineers and depending on the development difficulty, custom design can be proposed in 8 to 10 weeks.
- The first samples could require some tooling and development cost, but every effort will be made to propose consistent and as competitive as possible price for production volume.
- A specific datasheet for the custom product will be provided and the no obsolescence policy will guarantee the production over the years.

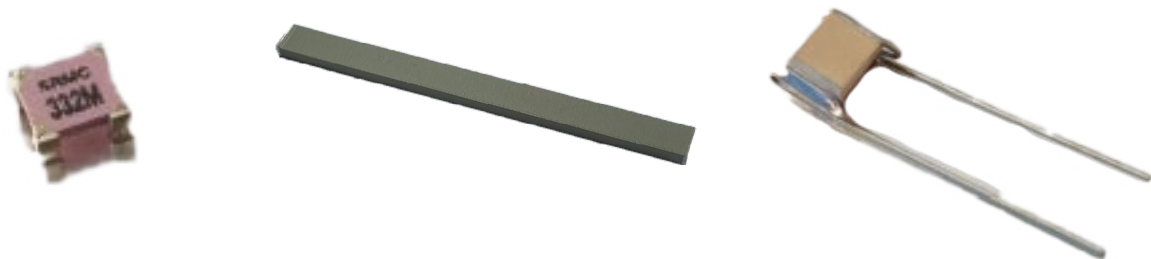



SIZE

SRT	EXXELIA	AVX	SYFER
0306 (on demand)		0306/LD16	
0402	CEC/CNC 19 ...SHL	0402	0402
0403 (on demand)	CEC/CNC 17		
0405 (on demand)			
0504	CEC/CNC 1		
0505	...SHA		
0508	CER/CNR 2	0508/LD17	
0603	CEC/CNC 19 R14 ...SHS	0603	0603
0612 (on demand)	CER/CNR 12	0612/LD18	
0709 (on demand)	...SHR		
0711 (on demand)	...SHD		
0805	CEC/CNC 2 R15 ...SHF	0805	0805
0907 (on demand)	CEC/CNC 18		
1005 (on demand)	CEC/CNC 8		
1111	...SHB/...NHB		
1206	CEC/CNC 12 R18 ...SHN	1206	1206
1210	CEC/CNC 4 S41 ...SHT	1210	1210
1515	C1/C2/C4 78		
1605	CEC/CNC 9		
1806	CEC/CNC 3		
1808			1808
1812	CEC/CNC 6 S43 C1/C2/C4 79	1812	1812
1825	CEC/CNC 70 C1/C2/C4 90	1825	1825
2210 (on demand)	CEC/CNC 5		
2220	CEC/CNC 7 S47 C1/C2/C4 80 ...CLX	2220	2220
2225	CEC/CNC 71 C1/C2/C4 91 ...R2225 ...CPX	2225	2225
2528 (on demand)	CEC/CNC W		
2825	C1/C2/C4 81		
3030 (on demand)	CEC/CNC X		
3040 (on demand)	CEC/CNC 72		
3033	...R3033		
3333	C1/C2/C4 82		
3640		3640	3640
3740	...R3740		
4040	C1/C2/C4 83 ...CPE/...CLE		
5440	C1/C2/C4 84 ...R5440		
5550	C1/C2/C4 89 ...R5550		5550
6080	...R6080		
6560	C1/C2/C4 85		
7065	...CLF		
8060	...R8060		8060
45107 (on demand)	...R45107		
11283 (on demand)	C1/C2/C4 87		
16080 (on demand)	C1/C2/C4 88		

CERAMIC

CERAM	SRT	EXXELIA	AVX	SYFER
NPO	xxA...	CEC CER ...R..N C1...	...A	C/Q/U/A/K/F/G
BX	xxX...	CNC		B
2C1	xxBY...	CNC		R
X7R	xxY...	CNC CNR ...R..X ...R...T C2...	...C	X/J/S/E/D
High Q	xxQ...	...CH ...SH ...CL ...CP		



TERMINATION

CERAM	SRT	EXXELIA	AVX	SYFER
Ag	Q	Q		
Ag+Ni+dipSn/Pb60/40	H	T		
Ag/Pd/Pt+dipSn/Pb60/40	on demand	H		
Ag+Ni +eISn/Pb95/5	I	C		
Ag+Ni +eISn/Pb60/40	on demand	D		
Ag+Ni +dipSn/Pb60/40	H	E		
Ag+Ni+Au	W	G	G	
Ag+PoLY+Ni+Sn/Pb95/5	on demand	YC		
Ag+PoLY+Ni+Sn/Pb60/40	on demand	YD		
Ag+ Poly +Ni+Au	on demand	YG		
Ag/Pd/Pt ROHS	F	W		
Ag ROHS	Q	QW		
Ag/Pd/Pt+ dip Sn ROHS	on demand	HW		
Ag+Ni+ eI SnAg ROHS	on demand	CW		
Ag + Ni + eI Sn ROHS	X	EW	T	J
Ag + Ni + Au ROHS	W	GW		
Ag+Poly+Ni+Sn ROHS	P	YCW	Z/X	H
Ag+ Poly +Ni+Au ROHS	on demand	YGW		
Sn/Cu/Ag	C	C		2
Ag/Pd	F	A	1	F



SIZE

LEAD SP MM	SRT	EXXELIA	AVX	SYFER
2,54	SRMC31	TC 77-5 TCN 72-5	SR15	8111M LE0805
	SRMC32	TCE TCX TCN TXR 78-5 TCN 73-5	SR20	8121M LR1206
4,32	SRMC38	TKD 79 TKD 90	SV01	LE1515
5,08	SRMC40	TCE TCX TCN TXR 77-1 TCE TCX TCN TXR 78-1 TCN 72-1		LD0805 8111N LD1206 LD1210
	SRMC41	TCL 79 TCL 90 TCF 78 TCN 73-1	SR21	
	SRMC43	TCF 79 TCL 80 TCL 91 non magn S43		LE1812
	SRMC44	TCE TCX TCN TXR 79-5 TCN 74-5 R 2225 TCF 80 TCF 90 TCF 91 non magn S47	SV13/SV63 SR30	8131M LB2225
	SRMC45	TCE TCX TCN TXR 80-5 TCN 75-5 TEF 3033 R 3033	SR40 SV14/SV64	8141M
5,60	SRMC47	TKD 80 TKD 91	SV02/SV52	
6,35	SRMC48		SR22	LQ1206
7,00	SRMC49	TKD 81	SV03/SV53	LE2520
7,62	SRMC52		SR27	
	SRMC54	TCL 81 TCF 81	SV04/SV54	8121T 8131T
9,52	SRMC58	TKD 82	SV05/SV55	LE3530
10,16	SRMC60	TCL 82 TCF 82		
	SRMC63	R 3740 TEF 3740 TCE TCX TCN TXR 76-5	SR50 SV15/SV65	8151M
12,10	SRMC68	TKD 83	SV07/SV57	LE4540
12,70	SRMC72	TCL 83 TCF 83		
	SRMC74	TKD 84 TEF 5550	SV08/SV58	8161M LE5550
15,24	SRMC76	TCL 84 TCL 89 R 5550 TCF 84		
	SRMC80	R 6080 TEF 6080		
17,10	SRMC82	TKD 85	SV09/SV59	LE6560 8165M
	SRMC84	TCL 85 TCF 85 R 6560		
20,30	SRMC88	R 8060	SV17/SV67 SV16/SV66	LE7565
21,00	SRMC90	TEF 8060		8111M
	SRMC91	TKD 87	SV10	
29,94	SRMC92	TCL 87 TCF 87	SV11	
	SRMC96	TKD 88 TCL 88 TCF 88		

CERAMIC/TERMINATION

CERAM	SRT	EXXELIA	AVX	SYFER
NPO	SRMCxxA...	TCE...	SRxxxA...	81...C...
		Non magnetic N... TCK1... TCL1... TCF1... TKD1...	SLxxxA... ARxxxA...	LE0805
BX	SRMCxxX...	TCX...	SR20	8121M LR1206
X7R	SRMCxxY...	TXR... Non magnetic X... TCK2... TCL2... TCF2... TKD2...	SRxxxC... SLxxxC... ARxxxC...	81...X...



SIZE

LEAD SP MM	SRT	EXXELIA	AVX	SYFER
2.54	SR41	TCE TCX TCN TXR 61 LA 1 LA 2 TCE 11 L/Y TCN 31 Y TCE 13 L/Y		
	SR43	TCE TCX TCN TXR 62 TCE 11 L/I TCN 31 I TCE 13 L/I	MR04	
4.32	SR45			Syfer 1515
5.08	SR47	TCE TCX TCN TXR 62N CK 05 TCE 11 NY TCN 31 NY TCE 13 NY		
	SR50	TCE TCX TCN TXR 50 TCE TCX TCN TXR 62N LA 3 TCE 11 N/I TCN 31 N/I TCE 13 N/I TCN 19 low capa	MR05	
	SR60	TCE TCX TCN TXRK 79 TCE TCX TCN TXRK 90 CK 06 TCE TCX TCN TXR 60 TCE TCX TCN TXR 63 LA 5A LA 5B LA 5C TCE TCX TCN TXRK 80 TCE TCX TCN TXRK 91 TCE 11 L/J TCN 30 J TCE 13 L/J TCN 31 J TCN 19 high capa	MR06	
	SR64	TCE TCX TCN TXR 64 TCE 11 L/O TCN 30 O TCE 13 L/O TCN 31 O		Syfer 2520
7.62	SR65	TCE TCX TCN TXRK 81		-
10.16	SR68		MR07	
	SR70		MR08	Syfer 4540
12.20	SR74	TCE TCX TCN TXRK 82		Syfer 5550
15.20	SR78	TCE TCX TCN TXRK 84 TCE TCX TCN TXRK 89		
17.30	SR82	TCE TCX TCN TXRK 85		Syfer 6560
19.80	SR86			Syfer 7565
27.90	SR90	TCE TCX TCN TXRK 87		
40.60	SR94	TCE TCX TCN TXRK 88		

CERAMIC/TERMINATION

CERAM	SRT	EXXELIA	AVX	SYFER
NPO	SRxxA...	TCE... TCK1... LA1-5	MRxxxA...	xxxxN... xxxxRN...
BX	SRxxX...	TCX...		
2C1	SRxxBY	CK5.. CK6...		
X7R	SRxxY...	TCN TCK2 TCK4	MRxxxC...	xxxxB... xxxxRB...



SIZE

DIAMETER	SRT	EXXELIA	AVX	KEMET
2.5	SA40...	TC52R...	MA10...	C114...
	SA50...		MA20...	C124...
3.9	SA60...	TC53R...		
	SA70...	TC54R...	MA30...	C192...
5.5	SA75...	TC55R...		
6.4	SA80...		MA40...	C202...

CERAMIC/TERMINATION

CERAM	SRT	EXXELIA	AVX	KEMET
NPO	SAXxA...	TCE...	MA...A...	C....G...
BX	SAXX...	TCX...		C....X...
2C1	SAXxBY	TCN...		
X7R	SAXxY...	TXR...	MA...C...	C....R...



SIZE

SRT	EXXELIA	AVX
SRMC1210		
SRMC1812		
SRMC1825		
SRMC2220		
SRMC2225	SC00	
SRMC2825		
SRMC3033	SC01/TEV53	CH42-44/CH41-44
SRMC3640	SC02/TEV54	CH52-54/CH51-54
SRMC4040		
SRMC40150		CH82-84/CH81-84
SRMC5550	SC04/TEV55	CH62-64/CH61-64
SRMC6080	SC06/TEV56	CH72-74/CH71-74
SRMC60110		CH87-89/CH86-89
SRMC6660	SC05	
SRMC8060	SC07/TEV65	CH77-79/CH76-79
SRMC80100	SC10	
SRMC80150	SC12/TEV58	CH92-94/CH91-94

FORM

FORM	SRT	EXXELIA	AVX
L	...L...	...DL...	...0A7
J	...J...	...DJ...	...0A8
D	...D...	...DN...	...0A0
M	...M...		
4 Wires	...Ux...	...U4.../TEV...	...3xx4

CERAMIC

CERAM	SRT	EXXELIA	AVX
NPO	...A...		
X7R	...Y...	...X.../...T...	...C...



SIZE

SRT	EXXELIA	KEMET
SRTV1210...		
SRTV1812...		
SRTV2220...		L1G...69...
SRTV2225...		L1G...70...
SRTV3033...		
SRTV3640...		
SRTV4040...		
SRTV5440...		
SRTV5550...		
SRTV6560...		
SRTV6080...		
SRTV8060...		

EXEMPLE

- SRT : SRTV3740Y106KAT6BE25 = Exxelia : 500SV02X106KW2C



SERIES

EXXELIA	LECLANCHE CAPACITORS
A64	CKM 501-4BDF
A64S	MKP d
A74	CKM 501-4BDF
BIK	PPM g
HT77	KN g
KM 311	CKM 311
KM 501	CKM 501
KM 94	MKS SMD
KM711	MKP df / MKS df
KM82	MKS gb
KSP4	KC-4
MKT	MKT b
MPA4W	CKT 501-4BDF
PHM912	MKNHV
PLP3	PPM r
PLS3	KPh/KSh
PM 50	MKT g
PM 60	MKT d
PM 7	MKT df
PM 89	MKT-4 a
PM 90	MKT-4 g
PM 94	MKT SMD
PM90-R2	MKT SMF
PMA 64	MKT g/ga
PMR 64	MKP g
PP 20	PPM h
PP 78 A	PPM d
PP 78 R	PPM g
PP12W	PPM c2
PPS 16	KP
PRM 4	CKM 501-4BG
R64S	MKP g
RA 1	KPS d
RA 2	KPS d
RA 3	KPS d
RA 4	KPS d
RA 75	KPS d
SP270UL	MKS df
SP2767	PPM 110-1.0 dv (K)
SP289UL	MKS df
SP2961	MKT-4 50-4.7 a (K)
SP2962	MKT-4 50-15.0 a (K)
SP2986W	PAM 85-2.0 cv2 (K)
SP3187	PPM 150-047 c (K)
SP3188	PPM 210-025 c (K)



SRT
MICROCÉRAMIQUE
MLCC CAPACITORS

www.srt-mc.com

Rue Mons
Parc Technologique de L'oratoire
41100 Vendôme - France



*For any inquiry please contact
our commercial engineer team :*

T 02 54 67 50 50

@ contact@srt-mc.com